

# technical data sheet

**top**  
**Rack Jacks**  
**W.L.L. : 3 t to 20 t**

réf. : **T 2062 GB**  
rév. n° :  
date : **11/02**  
page : **1/1**

## FUNCTION :

Floor handling of heavy loads up to 400 mm lift. Robust and maintenance free, this type of jack is fully adapted to be used on worksite.

## DESCRIPTION AND PRINCIPLE OF USE :

The " TOP " rack jack is operated by a crank handle. Lifting is controlled by a crank operating through a ratchet wheel with a double retaining catch, giving the jack additional safety .

Lowering is by a locked ratchet, holding the load by friction discs.

The load can be lifted by the jack head or by the toe.

## ADVANTAGES :

- Robust construction.
- Working Load Limit applied on head and toe (except for models 16 and 20t).
- The gear wheels, the pinions and the rack are made of heat treated steel.
- The folding handle of the crank reduces the overall dimension of the jack during transport.
- Handles for transport are available on all models.

## CHARACTERISTICS :

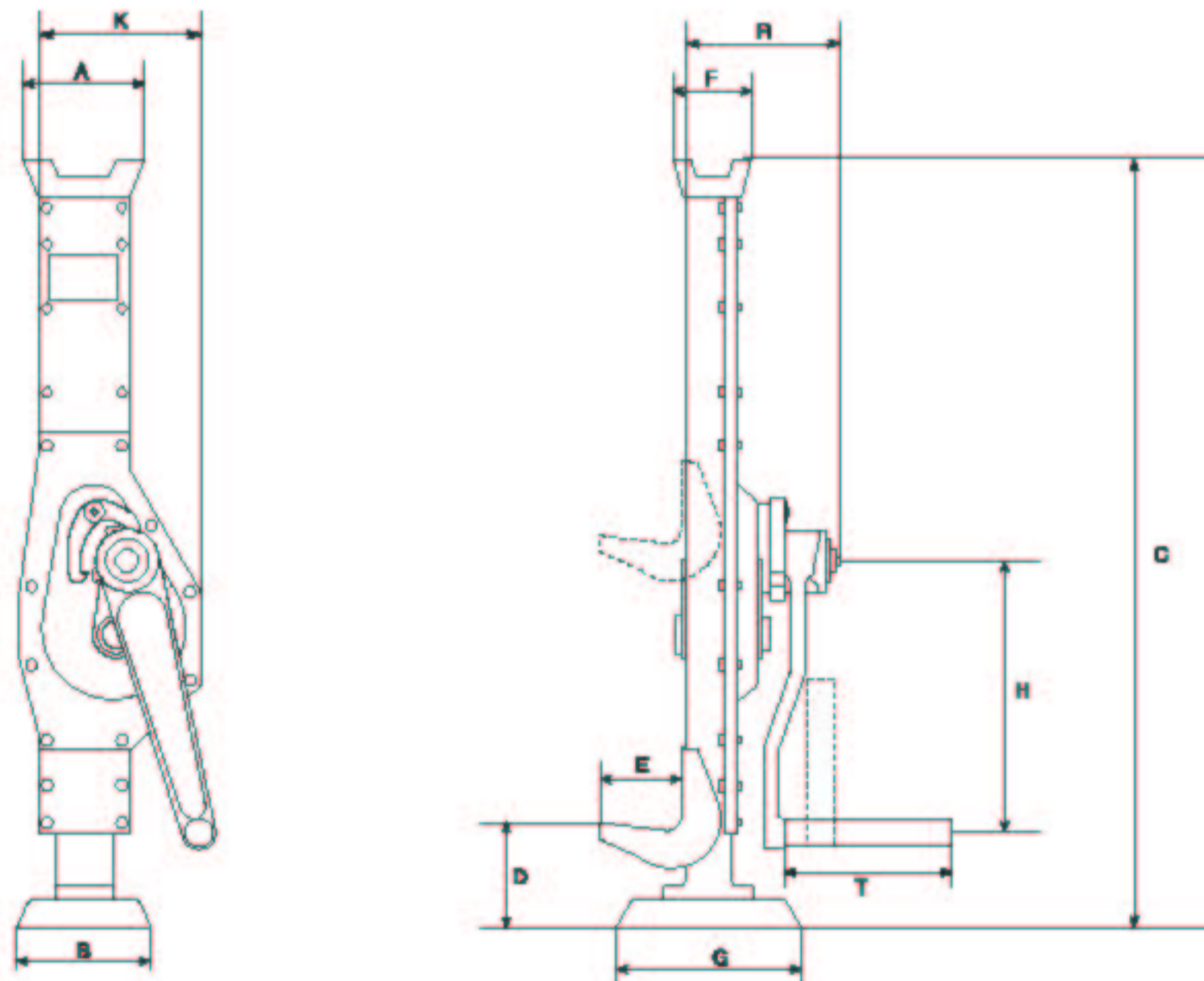

Model	W.L.L (t)		lift mm	Effort on handle (daN)	Weight kg	Dimensions (mm)										
	On head	On toe				A	B	C MIN	D MIN	E	F	G	H	K	R	T
BT 3	3	3	355	35	20	83	130	735	70	60	45	138	249	168	129	130
BT 5	5	5	345	40	28	108	140	735	80	71	68	170	249	190	146	130
BT 10	10	10	390	58	46	124	140	800	100	86	76	170	300	250	168	239
BT 16	16	11	320	73	65	135	200	900	160	75	85	230	400	270	220	280
BT 20	20	14	300	80	90	135	240	960	150	80	85	270	400	300	240	280