

Applications

Lifting without marking of products with parallel sides made of various materials such as wood, concrete, steel, plastic, rock...

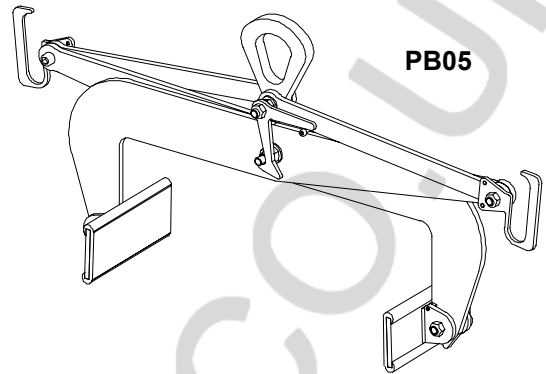

PB05

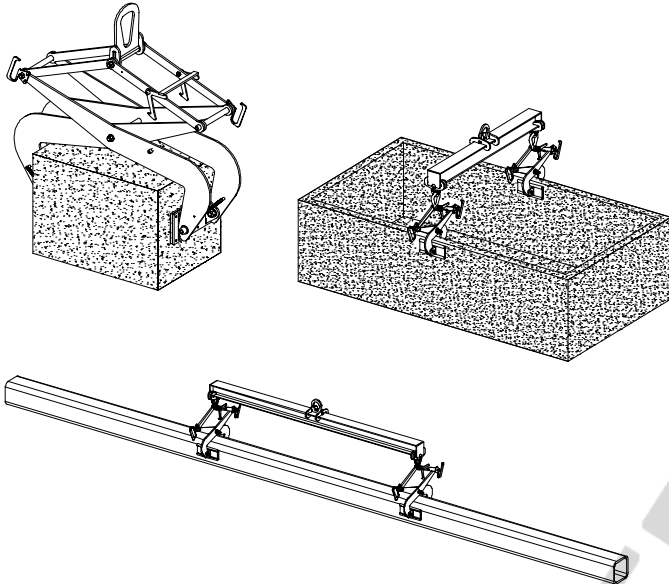
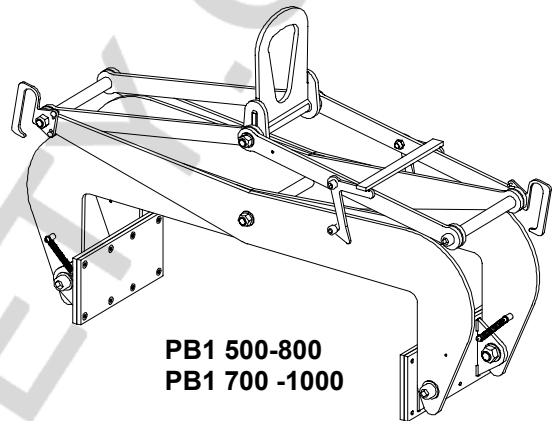

**PB1 500-800
PB1 700-1000**

Description

These accessories are fitted with an automatic lower lock allowing to lay down the load without any manual intervention. Rubber coated pads ensure a great adherence and avoid load marking. Transport handles make the positioning easier. Clamping is proportional to the load, thus limiting the damage risk.

Functioning

Place the clamp locked open over the load. Lift up the lever while starting off the lift and hold it in the up position to prevent it from locking again against the fastening screw. When laying down, the clamp automatically locks itself open.

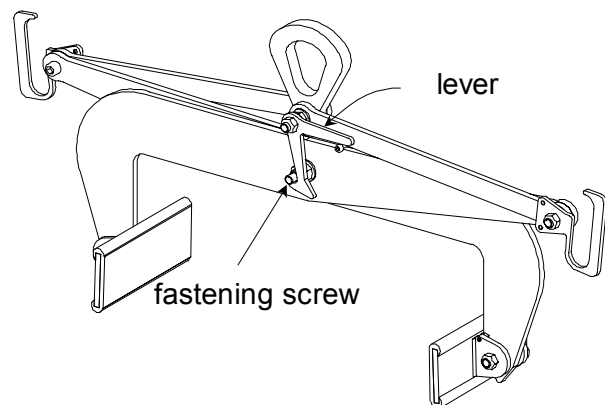

lever

fastening screw

Particular instructions

- Make sure the pads are free from grease or oil.
- Do not lift greasy or oily pieces or with smooth surface (eg. polished marble).
- Only lift one load at a time.
- Do not lift blocks with a size exceeding the opening capacity of the clamp used.
- Working temperature: -20° to +90°C.

technical sheet

PB
semi-automatic clamps
for loads with parallel sides

ref. : **T 6010 GB**
 rev. : **2**
 date : **Jun. 03**
 page : **2 / 2**

General characteristics

- Manufacture without load bearing welds.
- Hot epoxy coating.
- Safety factor: 4 in accordance with the European Materials Handling Federation (1998 FEM 3rd edition) ; working group A5 and lifting speed 60 m/ mn.

Dimensional characteristics

Ref.	Group code	WLL kg	Opening		A		B		C		D	E	F	G	H	I	J	K		Weight kg
			min	max	min	max	min	max	min	max										
PB05 0-100	50458	500	0	100	320	551	545	600	236	290	69	18	52	16	96	200	95	118	150	10
PB05 100-250	50468	500	100	250	340	684	575	680	345	440	69	18	52	16	96	200	95	113	127	12
PB05 200-500	50478	500	200	500	464	1031	823	975	578	734	80	23	64	20	96	200	95	203	261	20
PB1 0-200	50488	1 000	0	200	459	837	750	847	392	484	80	23	64	20	130	200	125	190	240	25
PB1 200-500	50498	1 000	200	500	550	1160	870	1085	635	812	80	23	64	20	130	200	123	175	240	47
PB1 500-800	50508	1 000	500	800	781	1370	1045	1200	1003	1146	170	38	110	10	150	300	289	287	337	71
PB1 700-1000	50518	1 000	700	1000	915	1481	1162	1304	1205	1330	170	38	110	10	150	300	286	364	407	78

Dimensions in mm

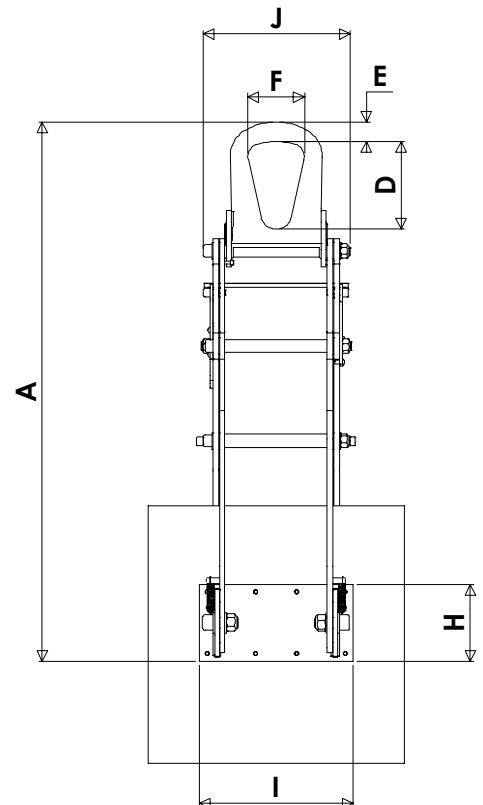
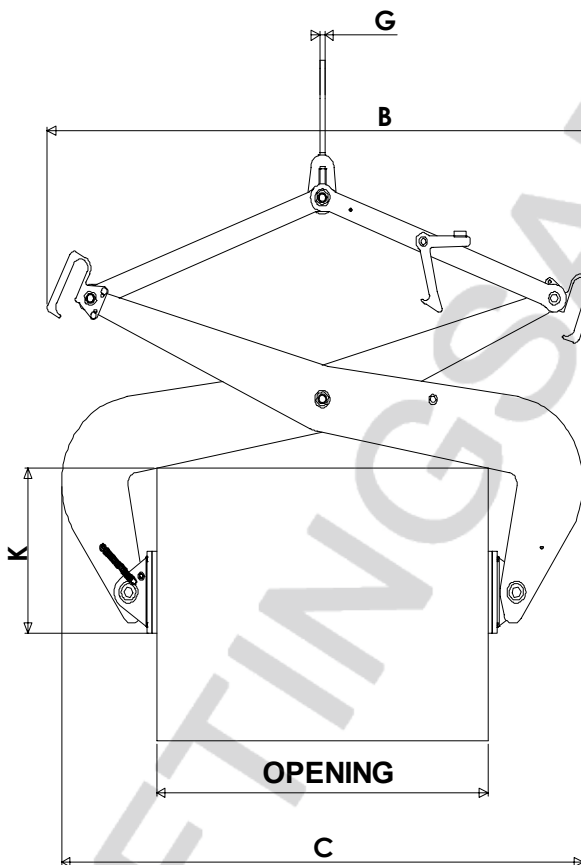

Options on request

- Pads coated with polyurethane/ abrasion steel.
- Pads with steel points (for slack loads).

