

supertirfor[®]

motorised lifting and pulling machines

models TU-16H
TU-32H

HYDRAULIC POWER PACKS
1, 2 or 4 way operation

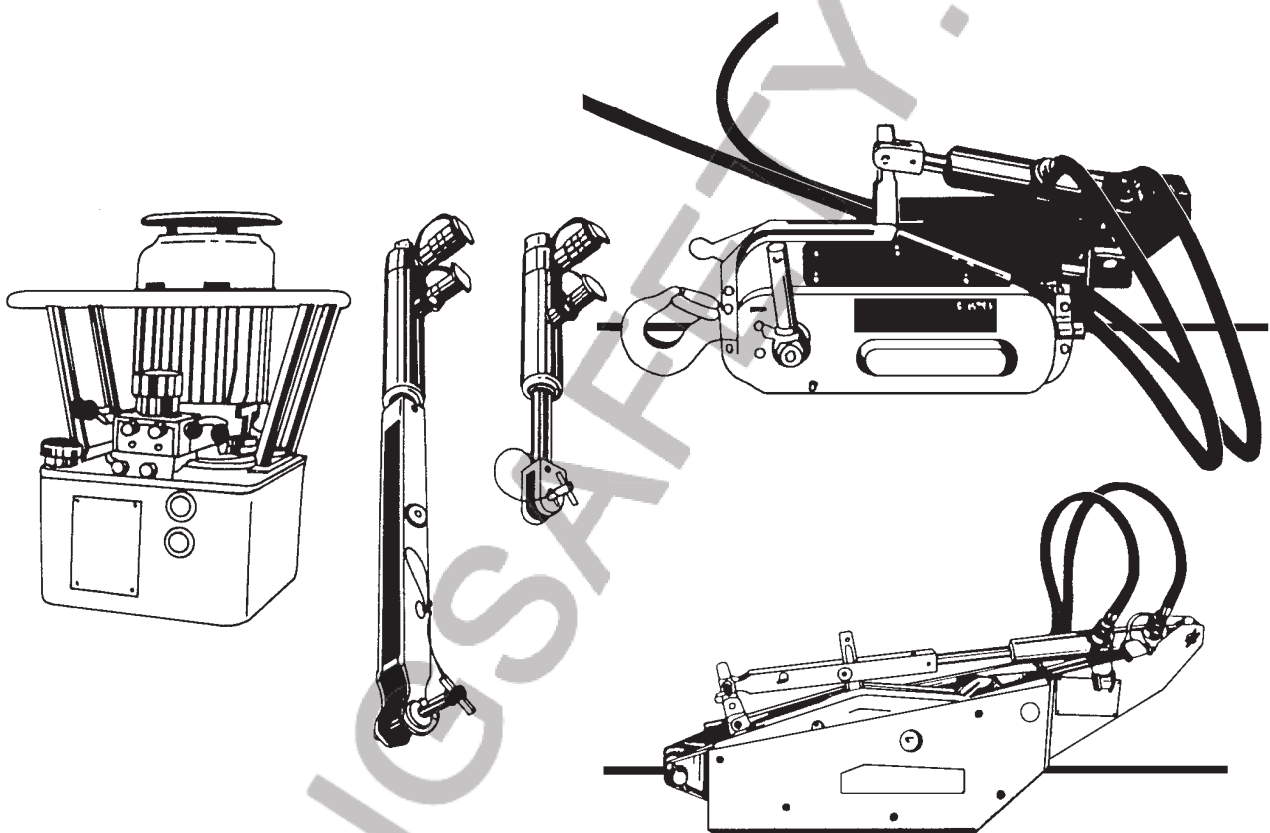

equipment in
accordance with
CE directives

**operating and
maintenance
instructions**

106925-03 - ind 01 - 09/02

®



®

ORIGINAL MANUAL

CONTENTS

	Page
General warning	2
Technical data	3
1. Description of equipment	4
2. Rigging arrangements	4
3. Installation	6
4. Releasing and engaging the jaws	8
5. Anchoring	9
6. Operation	10
7. Taking out of service and storage	11
8. Safety devices	12
9. Replacing the shear pins	12
10. Wire rope	13
11. Maintenance instructions	14
12. Warnings against hazardous operations	14
13. Troubleshooting	15
14. Health and safety at work	15

Always concerned to improve the quality of its products, the TRACTEL Group reserves the right to modify the specifications of the equipment described in this manual.

The companies of the TRACTEL Group and their agents or distributors will supply on request descriptive documentation on the full range of TRACTEL products: lifting and pulling machines, permanent and temporary access equipment, safety devices, electronic load indicators, accessories such as pulley blocks, hooks, slings, ground anchors, etc.

The TRACTEL network is able to supply an after-sales and regular maintenance service.

Fig. 1

Petrol Power Pack

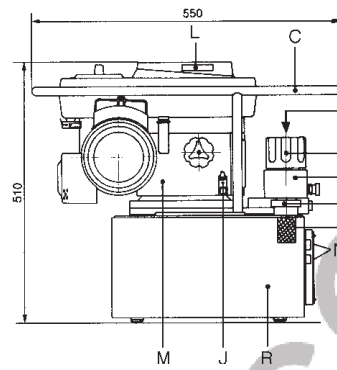

Electric Power Pack

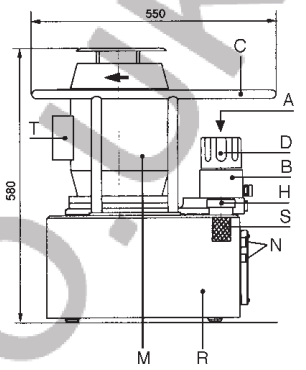

- | | |
|---|---------------------------------------|
| A : Pressure gauge | M : Motor (electric or petrol engine) |
| B : Control block | N : Hydraulic oil level indicators |
| C : Guard and carrying frame | R : Hydraulic oil reservoir |
| D : Flow regulator | T : ON/OFF switch (electric motor) |
| H : Reservoir filler cap | S : Filter |
| J : Oil level indicator (petrol engine) | |
| L : Starter cord (petrol engine) | |

TU16H fitted with ram

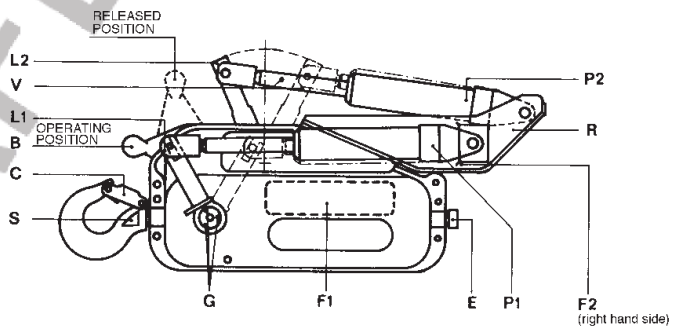

TU32H fitted with ram

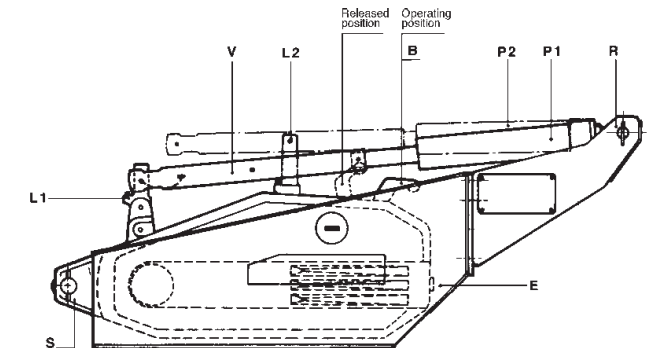

- | | |
|--------------------------------------|--|
| B : Rope release lever | S : Rope exit |
| C : Safety catch | V : Double-acting hydraulic ram |
| E : Rope guide | P1 : Position of ram for forward operation |
| F1-F2 : Operating instruction labels | P2 : Position of ram for reverse operation |
| G : Shear pins | R : Ram anchor bracket |
| L1 : Forward operating lever | |
| L2 : Reverse operating lever | |

⚠ **GENERAL WARNING** ⚠

1. Before using the SUPERTIRFOR® machine(s) and hydraulic power pack(s), it is essential for the safe and correct operation of the equipment **that this manual be read** and fully understood and that all the instructions be followed. **This manual should be made** available to every operator. Extra copies of this manual will be supplied on request.
2. The SUPERTIRFOR® machine allows the operator to carry out work with complete safety. Ensure that this machine is only handed over for use or rigging to an operator who is trained to operate it in a responsible manner.
3. Never use a machine which is not in good working condition. Replace any worn or damaged wire rope or hydraulic hose. Continuous monitoring of the condition of the machine, its wire rope and anchor sling, the hydraulic power pack and its motor and the hydraulic hoses is an important safety consideration.
4. The manufacturer declines any responsibility for the consequences of dismantling or altering the machine by any unauthorised person. Specially excluded is the replacement of original parts by parts of another manufacturer.
5. The models as described in this manual **must not be used for lifting people**.
6. Never apply to the machine a load or effort greater than the maximum working load.
7. SUPERTIRFOR® machines are not designed for use in explosive atmospheres.
8. **IMPORTANT** : If the equipment described in this manual is supplied to an employed person, check that you meet your obligations with respect to safety at work regulations (see section 14 on page 15).
9. On the electric power pack, check that the direction of rotation of the motor is correct, by switching the motor ON, then OFF. The motor should rotate clockwise. (See section 3.3.1 on page 7.)

LIFTING PEOPLE AND SPECIAL APPLICATIONS

For further information on equipment for lifting people, and for any special application, please refer to TRACTEL

TECHNICAL DATA

SUPERTIRFOR®

MODEL		TU-16H	TU-32H
Working load limit	t	1.6	3.2
Weight			
machine	kg	28	54.1
telescopic operating handle	kg	2.4	2.4
standard 20m of wire rope, complete	kg	13	31
Machine dimensions			
length	mm	788	1070
length with optional hook	mm	—	1290
height	mm	360	430
width	mm	185	204
telescopic handle : closed/extended	cm	68/119	68/119
TIRFOR® wire rope			
diameter	mm	11.5	16.3
guaranteed breaking strain*	daN	9600	19200
weight per metre	kg	0.54	1.06
Rope travel**			
forward, without load	mm	45	32.5
forward, with WLL	mm	37	14
reverse, without load	mm	42	35
reverse, with WLL	mm	44	25

HYDRAULIC POWER PACK

	1	2	4
No. of rams to be supplied	1	2	4
Control block	BC S	BC 2d	BC 4d
No. of hoses	2	4	8
Flow per ram	l/min	8	3.25
		13*	
Speed			
forward operation WLL*** TU16H	m/min	2	0.75
reverse operation WLL*** TU16H	m/min	2.3	1
forward operation WLL*** TU32H	m/min	0.7**	0.17
reverse operation WLL*** TU32H	m/min	1.6**	0.4

* **NEVER CONNECT A TU16H MACHINE TO AN OUTPUT OF 13 l/min.**
 ** Connected to the 13 l/min outlet.
 *** Working Load Limit

* Including end fittings of the wire rope
 ** One complete cycle of the operating lever

1. DESCRIPTION OF EQUIPMENT

1.1. SUPERTIRFOR®

The SUPERTIRFOR® machine is a power-operated lifting and pulling machine. It is versatile, portable and multi-purpose, not only for pulling and lifting but also for lowering, tensioning and guying. The originality of the SUPERTIRFOR® machine is the principle of operation directly on the wire rope which passes through the mechanism.

The effort is applied to the operating levers (forward or reverse) by a double-acting hydraulic ram (or, if required, by a telescopic operating lever). The SUPERTIRFOR® is fitted with a hook or anchor pin, depending on the model, so that it can be secured quickly to any suitable anchor point.

1.2. Hydraulic power pack

1.2.1 Hydraulic power pack with electric motor

The hydraulic power pack may be supplied with an electric motor for 400V or 230V, 3 phase supply. It is operated from a push-button control box and allows 1 to 4 SUPERTIRFOR® machines to be operated simultaneously. The power pack has a pump which delivers a flow of 8 l/min. for the model fitted with a one-way control block or a pump which delivers a flow of 13 l/min. for the model fitted with a one-, two- or four-way control block.

1.2.2 Hydraulic power pack with petrol engine

The hydraulic power pack may be supplied with a petrol engine. It allows 1 to 4 SUPERTIRFOR® machines to be operated simultaneously. The power pack has a pump which delivers a flow of 13 l/min. and is fitted with a one-, two- or four-way control block.

1.2.3 Control blocks

The hydraulic power pack may control from one to four SUPERTIRFOR® machines simultaneously. For this the control block must have as many outlets as machines.

NOTE : The one-way control block on a power pack fitted with a 13 l/min. pump has two separate outlets: one delivers a flow of 13 l/min for connecting only to a model TU32H and the other delivers a flow of 8 l/min. for connecting to the model TU16H. **Never connect the SUPERTIRFOR® TU16H to the outlet delivering a flow of 13 l/min.; to do so would damage the hydraulic ram.**

The 2 or 4 way control blocks have a 1 or 2 stage flow dividing device which delivers to each ram a half or quarter of the flow from the pump,

independently of the pressure or length of the hoses on each ram.

1.2.4 Standard set of equipment

A standard set of equipment comprises :

- a hydraulic power pack fitted with an electric motor or petrol engine
- one or more sets of hydraulic hoses
- one or more SUPERTIRFOR® machines fitted with an anchor bracket and self-reciprocating hydraulic ram
- a 25 l drum of special hydraulic oil
- one or more special wire ropes with end fittings and wound onto a reeler

This manual and a guarantee card are attached to each machine, together with the CE declaration of conformity.

IMPORTANT : TIRFOR® wire rope has been specially designed to meet the particular requirements of the SUPERTIRFOR® machine. The manufacturer does not guarantee the safe operation of the machines used with wire rope other than TIRFOR® wire rope.

2. RIGGING ARRANGEMENTS

The machine may be anchored to a fixed point with the wire rope travelling towards the machine (Figs. 2.1, 2.2, 2.3), or travel along the wire rope, with the load, the wire rope itself anchored to a fixed point (Fig. 2.4).

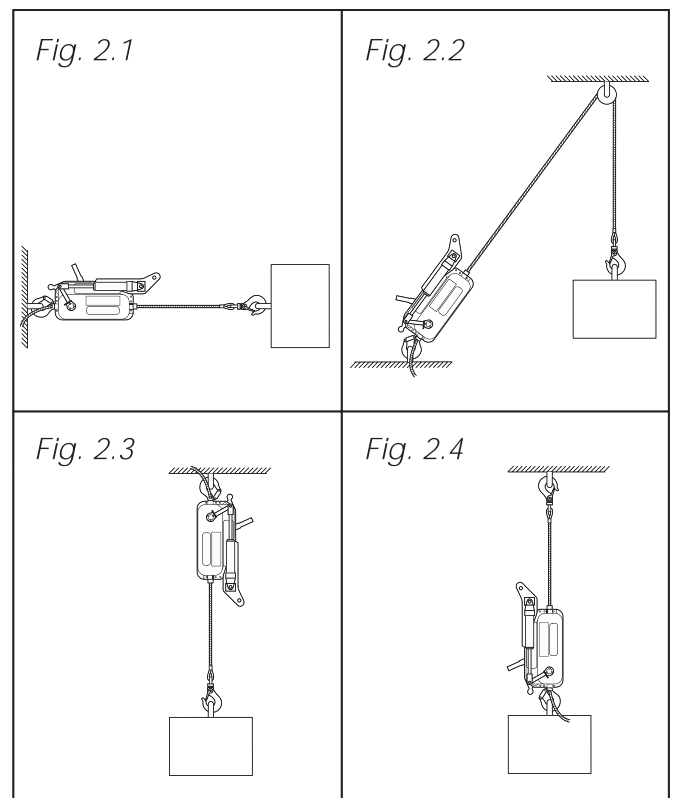

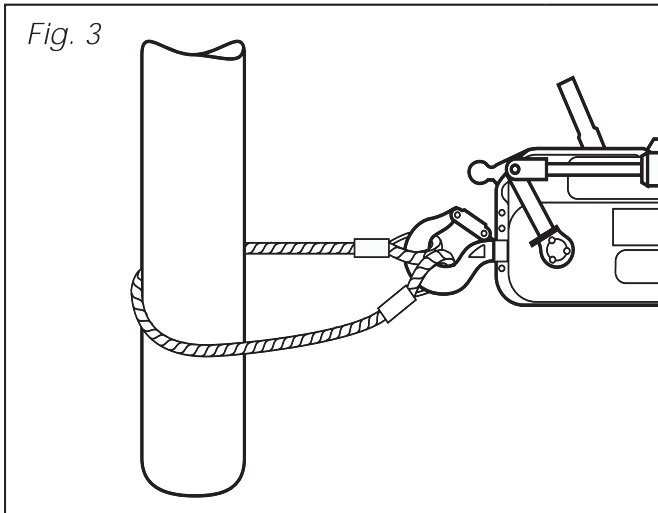

N.B. : Whatever the rigging arrangement, and if the machine is anchored to a fixed point, ensure that there are no obstructions around the machine which could prevent the wire rope, the machine and anchor from operating in a straight line. It is therefore recommended to use a sling of an appropriate capacity between the anchor point and the machine (Fig. 3).

N.B. : Where the rigging arrangement shown in Fig. 2.4 is used the user's attention should be drawn to the danger of trapping the hydraulic hoses, pressure and return. The rigging arrangement must take into account the movement of the hoses with the machine. As far as possible this rigging arrangement is to be avoided.

N.B. : Whatever the rigging arrangement, always make sure that the hydraulic hoses, pressure and return, are free to move and are not restrained or trapped, particularly over sharp edges.

⚠ WARNING ⚠ : Any rigging arrangement which requires the calculation of the forces applied should be checked by a competent engineer, with special attention to the appropriate strength of fixed point used.

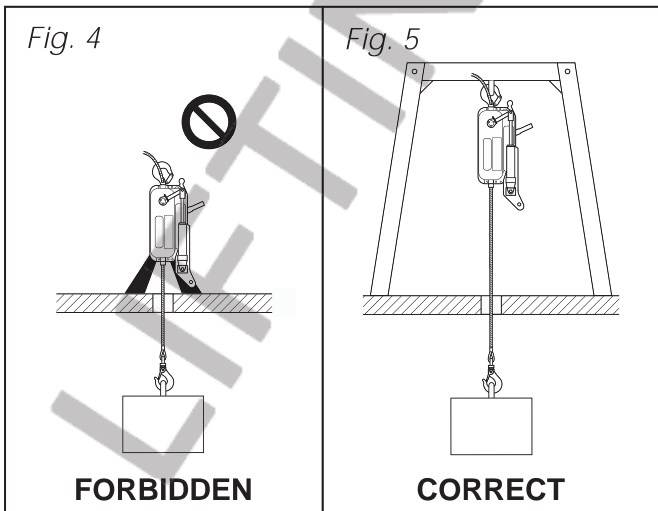

For work such as guiding the trunk in tree felling, the operator should ensure that he is outside the danger area by passing the wire rope around one or more return pulleys.

The capacity of the machine may be increased considerably for the same effort by the operator by using multiple sheave blocks. (See the examples set out in Figs. 6.1 and 6.2). The increase in the capacity shown is reduced depending on the efficiency of the pulleys.

The diameter of the pulleys used should be equal to at least 18 times the diameter of the wire rope. (Refer to the applicable regulations).

For any rigging arrangement other than those described in this manual, please consult TRACTEL or a competent specialist engineer before operating the machine.

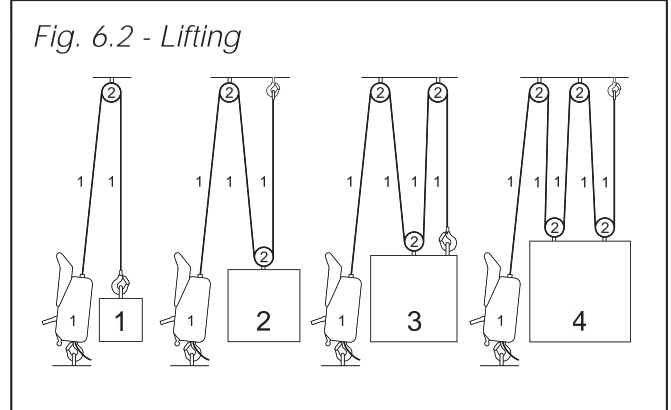
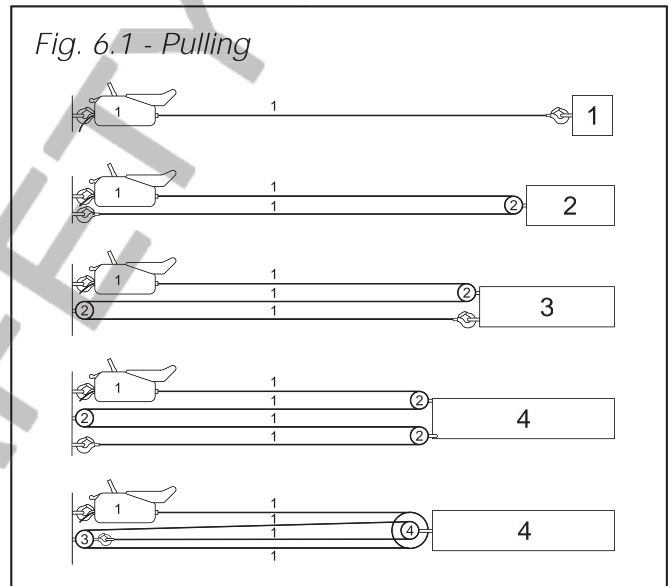

3. INSTALLATION

3.1. SUPERTIRFOR® machines

3.1.1 TU16H

1. If not already fitted, mount the anchor bracket onto the machine. To do this, use a 13mm tube spanner. Remove the 6 screws and washers, item 1, the bolt and its washer, item 2, and slightly loosen the 4 screws, item 3, as shown in Fig. 7. Mount the anchor bracket, taking care to centre the fixing holes. Refit the 6 screws and washers, item 1, reposition and fit the bolt and its washer, item 2, and retighten all the screws, items 1, 2 and 3 (see Fig. 7).

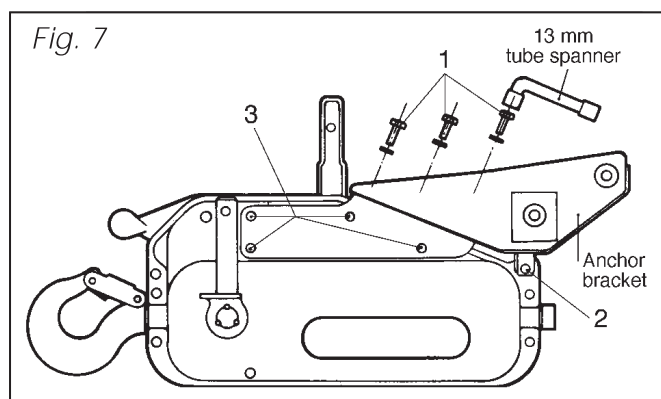

⚠ WARNING ⚠ : Whilst removing the screws, item 1, and during their replacement, take great care not to let any of the washers fall inside the TU16H. If any of the washers does fall inside the machine, it must be removed.

DO NOT USE ANY MACHINE INTO WHICH A WASHER HAS FALLEN UNTIL IT HAS BEEN REMOVED

2. Using the anchor pin, fit the VA2 ram onto the bracket R (see Fig. 8) at the appropriate anchor point, depending on the direction required.

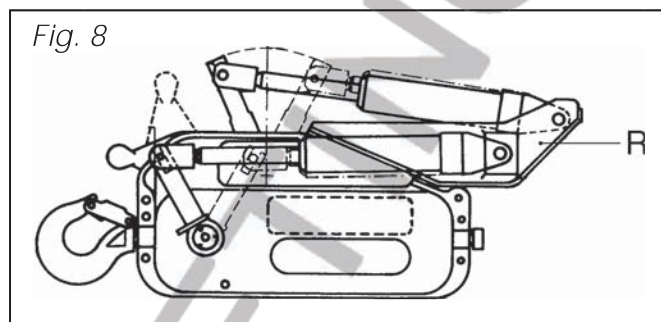

3. Using the anchor pin attached to the clevis at the end of the ram cylinder, fit the clevis to the appropriate operating lever.

NOTE : The anchor pin may be more easily fitted by moving the operating lever. Check that the anchor pins are correctly fitted into their housing.

A click may be heard when the anchor pin is correctly locked into position. Ensure that the anchor pins are well lubricated.

3.1.2. TU32H

Mount the VA3 ram onto the TU32H fitted with its anchor bracket by using the anchor pin, at the end of the machine where the wire rope is inserted into the SUPERTIRFOR®. Then fit the other end of the ram, with its protective rubber cover pointing downwards, to the forward or reverse operating lever, using the anchor pin attached. The anchor pins are fitted with spring clips. Check that these are correctly fitted and locked into position (see Fig. 9).

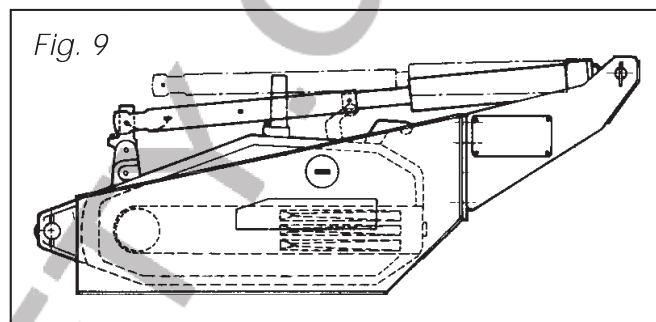

3.2. Wire rope

N.B. : When handling the wire rope it is recommended to protect the hands by using work gloves.

If the wire rope is to be anchored to a high anchor point, the wire rope should be anchored before fitting the wire rope in the machine.

1. Uncoil the wire rope in a straight line to prevent loops or kinks.
2. Release the internal mechanism of the machine (see section 4 : Releasing and engaging the jaws).
3. Insert the wire rope through the rope guide at the end opposite to the anchor point (hook or anchor pin).
4. Push the wire rope through the machine, and if necessary, helping it by operating the forward operating lever.
5. When the wire rope appears through the anchor point, pull the slack wire rope through the machine, to the point required.
6. Engage the jaws by operating the rope release mechanism (see section 4 : Releasing and engaging the jaws).
7. Anchor the SUPERTIRFOR® machine or the wire rope to the appropriate fixed point (see section 5 : Anchoring) taking care to ensure that the anchor point (hook or anchor pin, depending on the model) is correctly fixed.

3.3. Hydraulic power pack

NOTE : The following operations should preferably be carried out at the factory before going to site.

N.B. : The hydraulic power packs are supplied without oil in the reservoir for safety reasons during transport.

1. Remove the reservoir cap (H) and fill the reservoir with hydraulic oil.

ATTENTION : Do not remove the filter. Fill the reservoir until the level reaches the upper oil level indicator N.

2. Refit the reservoir filler cap correctly.

ATTENTION : This operation of filling the reservoir should be carried out with great care to avoid the introduction of dust or any foreign matter into the reservoir. If possible this should be done before leaving the factory or warehouse for the construction site.

3. Fit the hydraulic hoses to the power pack. The pressure hoses, which have an indent mark on the connecting nut, should be attached to the outlet on the control block with the same indentation.

NOTE : On a one-way control block, connect the hose to the 8 l/min. output for use with a TU16H or a TU32H. The 13 l/min. output is for use exclusively with a TU32H. Where a power pack with an 8 l/min. pump is used, the 13 l/min. output becomes 8 l/min. and the 8 l/min. output should be blocked off (see Fig. 10).

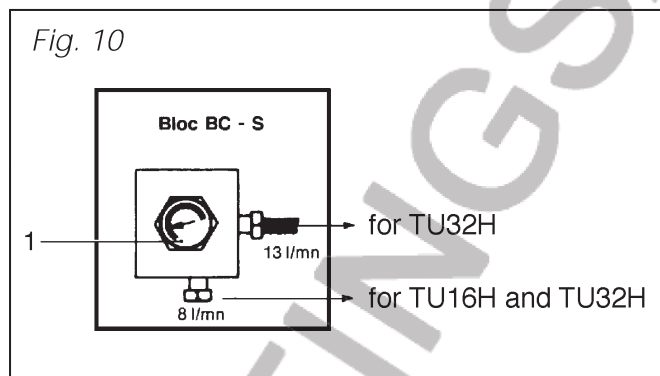

NEVER CONNECT A TU16H MACHINE TO AN OUTPUT OF 13 l/min.

3.3.1 Power pack with electric motor

Check the voltage of the power supply: 400V or 230V, 3 phase, 50 Hz. The motors of the hydraulic power packs are wired at the factory for use with a voltage of 400V. The hydraulic power packs will operate on 230V. Changing the voltage should only be carried out by a qualified electrician. To change the voltage, proceed as follows :

1. Check that the machine is not connected to the mains power supply.
2. Open the electric control box, using an 8mm flat or tube spanner to unscrew the 4 hexagonal headed screws with washers.
3. Remove the cover, taking care not to damage the weatherproofing seal.
4. Make the electrical connections according to the layout in Fig. 11 and connect the electrical contactor spool depending on the voltage required.

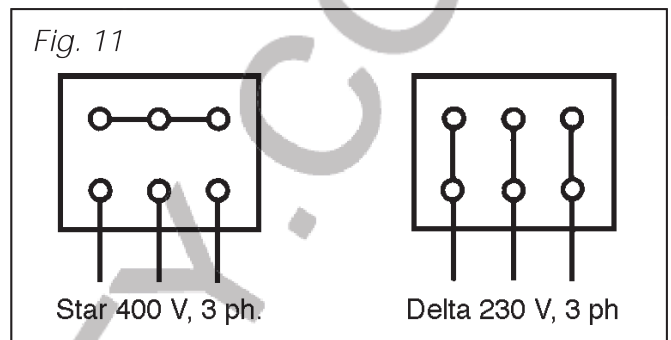

It is possible that the mains supply is reversed with regard to the direction shown on the electric motor. In case of phase reversal, using a screwdriver, turn the phase inverter, inside the male plug, 180 degrees, to put the phases into the correct order (see Fig. 11a).

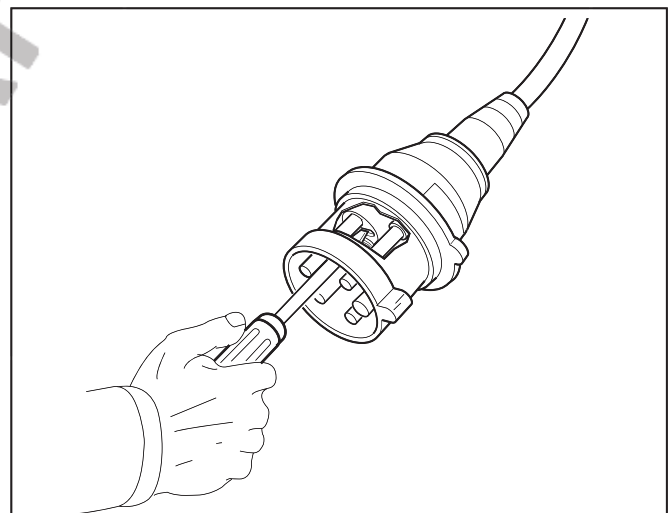

Fig. 11a : Reversing the phases on the power supply plug

3.3.2 Power pack with petrol engine

1. Fill the petrol tank with ordinary petrol (with or without lead).
2. Check the engine oil level and refill if necessary, in accordance with the engine manufacturer's instructions.
3. Connect the two hoses together, pressure and return, using the quick connecting couplings, to "bleed" the hydraulic circuit.

4. Open the flow regulator D fully (ON position) and put the lever(s) to the open position (with the lever pointing upwards).
5. Start the engine, using the starter cord L. Follow the engine manufacturer's instructions.
6. Let the engine idle for 4-5 minutes to bleed the hydraulic circuit.
7. Stop the engine by operating the circuit breaker W.
8. Close the levers (back to the horizontal position) and turn the flow regulator to the OFF position. Top up the hydraulic oil reservoir to the middle of the upper sight glass (N). The quantity of oil to be added depends on the length of the hoses and the number of rams connected to the system.
9. When the "bleeding" operation is completed, disconnect the hydraulic hoses. If the hoses are not immediately connected to the hydraulic rams, replace the dust caps on the couplings.

3.3.3 Hydraulic hoses

Each ram is connected to the control block of the power pack by two hoses. One hose is for the pressure circuit (HP) and the other for the return circuit (BP). A combination of male and female end fittings with quick connectors ensures correct assembly. The hoses are available with standard 10mm diameter (NW10) and standard lengths of 3,6 and 10m, available on request. Extension hoses are also available on request. If the application requires hoses of a different length, the table below shows the maximum length of hoses that may be used.

Table showing the maximum length of pressure and return hoses (per machine) as a function of the diameter (10 mm) of hose and the flow of hydraulic fluid.

HOSE	TU16H	TU32H
1 way - 8 l/mn	14 m	10 m
2 way - 13 l/mn	16 m	10 m
4 way - 13 l/mn	25 m	15 m

N.B.

- The lengths stated are for a single continuous hose without intermediate connectors.
- For greater distances, use 13 mm diameter hoses and consult the manufacturer.

4. RELEASING AND ENGAGING THE JAWS

4.1. TU16H (Fig. 12)

Releasing :

1. Completely press the rope release safety catch (5) and lift the rope release lever (4).

2. Release the safety catch and continue to lift the rope release lever until it locks into position. The internal mechanism is in the released position.

Engaging :

1. Lift the rope release lever slightly.
2. Press and maintain pressure on the rope release safety catch, allowing the release lever to slowly travel back to its original position. Release the safety catch. The release lever locks in position under the effect of its spring.

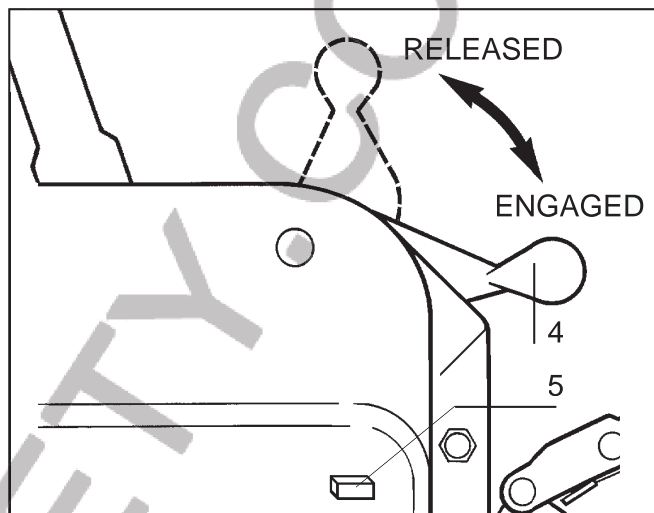

Fig. 12 - TU16H. Rope release lever

NOTE : For the TU16H, releasing or engaging the jaws may be carried out before or after the ram has been mounted in the anchor bracket.

4.2. TU32H (Fig. 13)

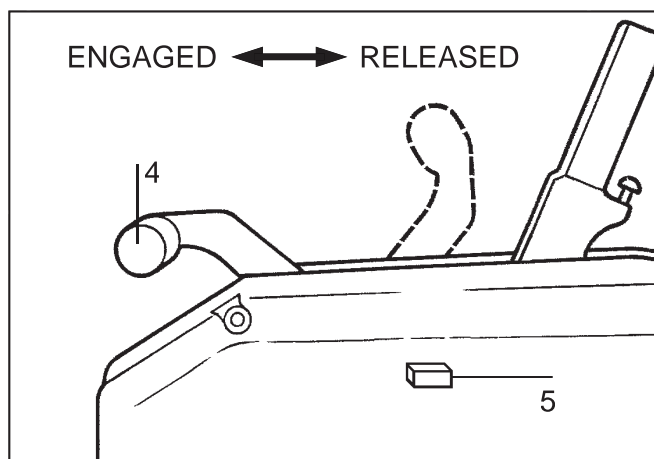

Fig. 13 - TU32H. Rope release lever

Place the anchor point against a support.

Releasing :

1. Completely press the rope release safety catch (5) and push the rope release lever (4) towards the anchor point.
2. Release the safety catch and continue to push the rope release lever until it locks into position. The internal mechanism is in the released position.

Engaging :

1. Push the rope release lever towards the anchor point.
2. Press and maintain pressure on the rope release safety catch, allowing the release lever to slowly travel back to its original position. Release the safety catch. The release lever locks in position under the effect of its spring.

NOTE : For the TU32H, releasing or engaging the jaws must be carried out before connecting the ram to the forward or reverse operating lever. Should the ram be already mounted, disconnect the anchor pin from the operating lever and rotate the ram vertically on the other anchor pin at the rear of the anchor bracket. This allows access to the rope release lever.

5. ⚠ ANCHORING ⚠

Failure to anchor the SUPERTIRFOR® machine correctly runs the risk of a serious accident. The user must always ensure before operation that the anchor point(s) for the machine and wire rope is/are of sufficient strength to hold the load.

It is recommended that SUPERTIRFOR® machines should be anchored to a fixed point or to the load using an appropriate capacity sling. **It is forbidden to use the machine's wire rope as a sling** by passing it around the load and hooking it back onto itself (Fig. 14 : incorrect anchoring arrangement; Fig. 14a : correct anchoring arrangement).

The anchor arrangement on the model TU16H is a hook fitted with a safety catch (Fig. 15 and 16). In all cases, the anchor arrangement should always allow the safety catch to be closed correctly (Fig. 16). These same recommendations apply to the hook fitted to the wire rope.

The model TU32H is anchored by a removable anchor pin, passing through each end of the side case (Fig. 17 and 18) and locked in position by a two-position spring clip, closed or open (see Fig. 19 and 20).

If required, a hook arrangement is available to attach to the anchor pin of the model TU32H.

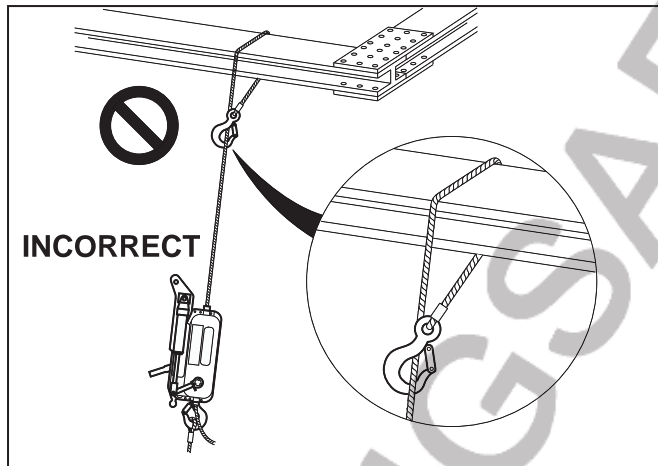

Fig. 14 - Incorrect slinging

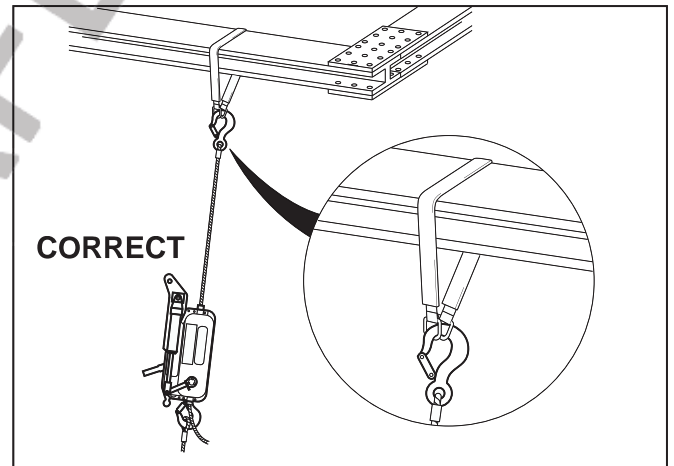

Fig. 14a - Correct slinging

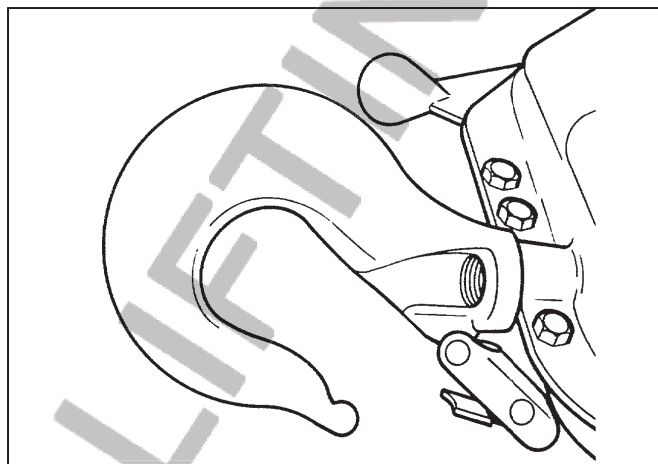

Fig. 15 - Machine anchor hook with catch in open position

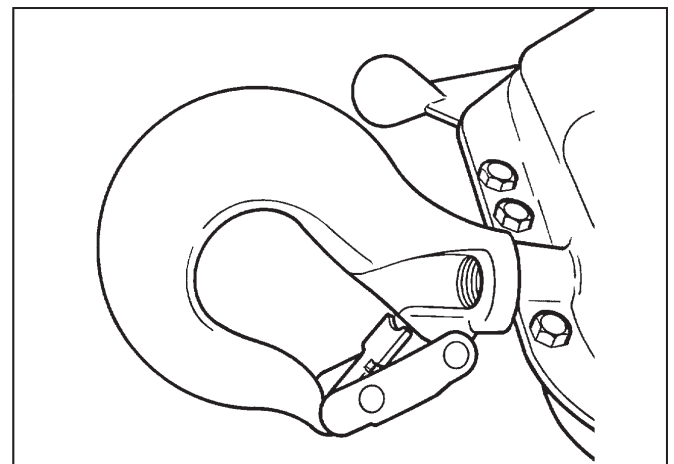

Fig. 16 - Machine anchor hook with catch in closed position

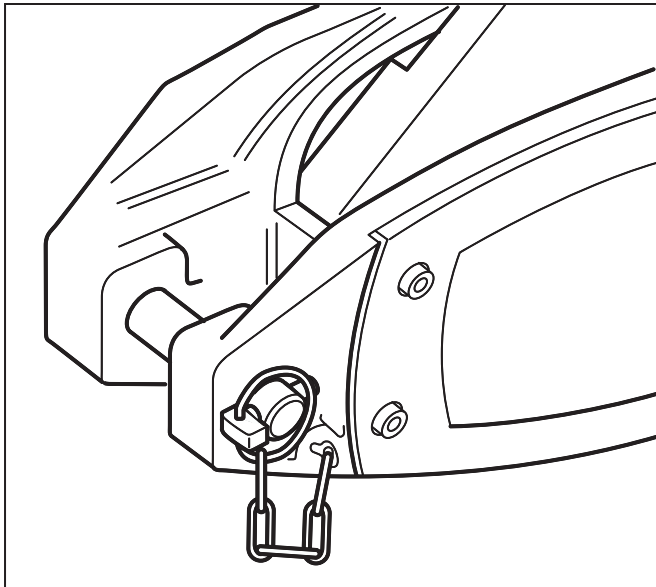

Fig. 17 - Anchor pin in position

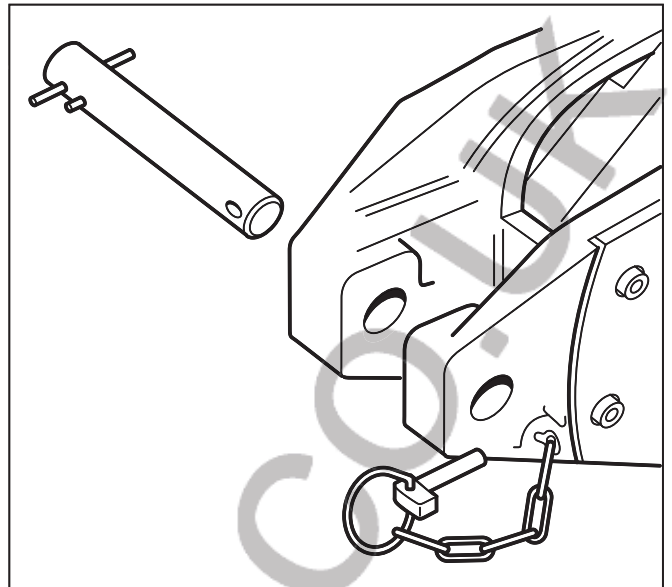

Fig. 18 - Anchor pin removed

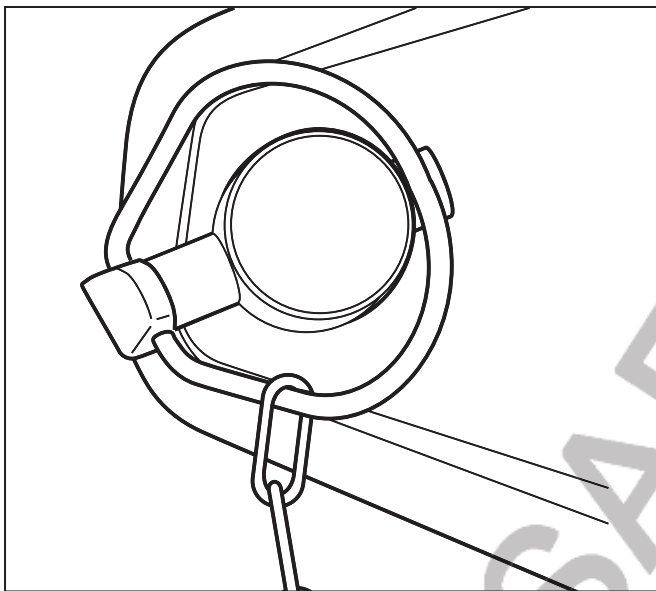

Fig. 19 - Spring clip closed

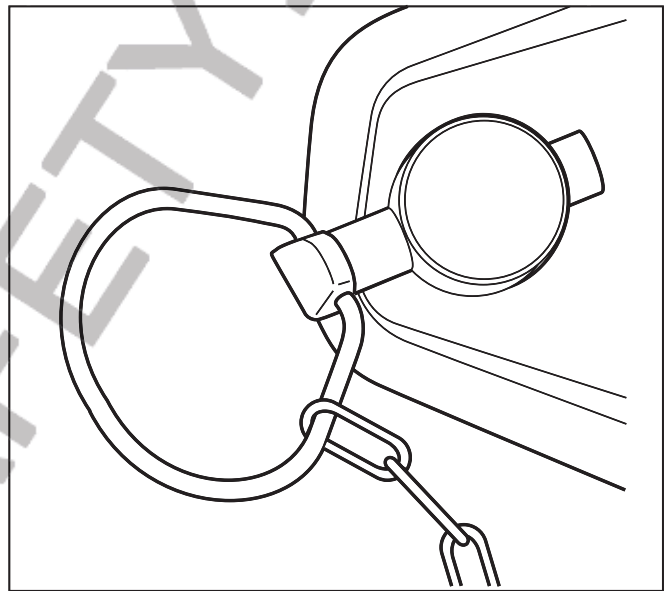

Fig. 20 - Spring clip open

To anchor using the anchor pin, follow the procedure below:

1. Open the spring clip of the anchor pin.
2. Remove the spring clip from the anchor pin.
3. Slide the anchor pin out of the side cases (Fig. 18).
4. Fit the anchoring arrangement, such as a sling, between the side cases.
5. Refit the anchor pin through the side cases and the anchoring arrangement, such as the eyes of a sling.
6. Refit the spring clip to the anchor pin.
7. Close the spring clip, ensuring that it fits correctly over the end of the anchor pin and cannot fall out.

⚠ Warning ⚠ : It is essential for the safe operation of the machine to ensure that, before loading the machine, the anchor points, hooks or pins, are correctly secured, (with the safety catch correctly located on the hook - Fig. 16).

6. OPERATION

1. Starting the motor of the hydraulic power pack.

Hydraulic power pack with electric motor:

Press the start button on the control box and manually hold the button depressed. Never block this button in the start position by any other means.

Hydraulic power pack with petrol engine :

Start the engine (see description in paragraph 3.3.2) referring to the instruction manual of the engine manufacturer.

2. Adjusting the speed of movement of the wire rope :
 - On a 1-way control, starting, stopping and speed of movement of the wire rope may be adjusted by turning the flow regulator (see item 1 on Fig.10) which supplies all or part of the flow from the pump to the ram.
 - On 2-way or 4-way controls, the speed of operation of the rams when used together is adjusted by turning the flow regulator (see item 1, Fig. 21). The speed of each ram can be adjusted separately by operating the control lever provided (see item 2, Fig. 21).

Fig. 21

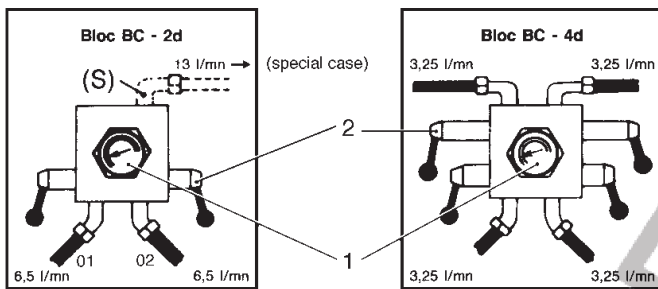

NOTE : The 2-way control, as an option, may be used as a 1-way block by connecting the hydraulic hose to the auxiliary outlet (S) for 13 l/in. flow. This usage must only be used in conjunction with a model TU32H.

NEVER CONNECT A TU16H TO A FLOW OF 13 l/min. Should this auxiliary outlet for 13 l/min. flow be used, outlets "01" and "02" (see Fig. 21) must be blanked off using special blanking plugs OBF 10 (Code 0519 325). For the return hose, only one will be used; the other must be blanked off.

When operation stops, both jaws automatically grip the wire rope and hold the load which is spread equally between the jaws.

The to-and-fro operation of the forward or reverse lever by the action of the self-reciprocating hydraulic ram gives continuous movement of the load.

In case of manual operation, SUPERTIRFOR® machines are very easy to use. Remove the hydraulic ram from the anchor bracket. Place the telescopic operating handle on either the forward or reverse operating lever, lock it into position by twisting and move the operating handle to-and-fro. The operating arc is variable for ease of operation.

7. TAKING OUT OF SERVICE AND STORAGE

Stop the hydraulic power pack. Open the flow regulator and the separate operating levers on the 2- and 4-way systems. Disconnect the hoses. Immediately fit the dust caps on the couplings.

NEVER ALLOW THE ENDS OF THE HOSES TO TRAIL ON THE GROUND.

Roll up the hoses in as wide a diameter as possible for storage. For electric power packs reel the electric cable around the electric motor.

NEVER HANDLE THE POWER PACK BY ITS SUPPLY CABLE.

For power packs with petrol engine, check that the motor has been correctly stopped.

TAKE GREAT CARE TO AVOID TOUCHING THE HOT EXHAUST SYSTEM, EVEN AFTER HAVING TURNED THE ENGINE OFF FOR SOME TIME.

It is essential to take the load off the machine before attempting to release the jaws. To do this, operate the reverse operating lever until there is no tension in the wire rope.

Remove the hydraulic ram from the anchor bracket.

Release the machine and follow the instructions for installing the wire rope in the reverse order (see paragraph 3.2). Re-engage the jaws of the machine before putting it into storage.

Store the machine and ram, wire rope, hoses and the hydraulic power pack in a dry place, away from the effects of the weather. Where a hydraulic power pack with petrol engine is used, make sure that the storage area is well ventilated. The wire rope should be completely removed from the machine and rewound onto its reeler.

Before reeling the wire rope, it is recommended to inspect it, clean it with a brush and then grease it.

Ideally, the hoses should be stored laid out horizontally in a straight line; or, in as large a circle as possible.

8. SAFETY DEVICES

8.1. SUPERTIRFOR® machines

8.1.1 Overload limiting safety devices

All machines incorporate a shear pin system. In case of overload, one or more pins (depending on the model), fitted to the forward operating lever, shear and prevent further forward or lifting operations. Reverse operation is still possible to enable the load to be lowered or the wire rope to be slackened.

When using a multiple control block, if one of the machines exceeds the working load limit, without shearing the shear pins, the whole of the installation stops. To remedy this situation, reduce the load or spread the load more evenly over each of the machines, or release (or lower) the load by operating, (using the rams), the reverse operating levers of the 2 or 4 SUPERTIRFOR® machines.

8.1.2 Rope release safety device

The machines are fitted with a "two-handed" rope release system which requires deliberate operation by the user to release the machine. See section 4 : Releasing and engaging the jaws.

8.2. Hydraulic power packs

8.2.1 "Dead man" device

A safety device, called "dead man", is fitted to electrically operated hydraulic power packs. It operates to stop the power pack if the push-button is released.

8.2.2 Safety valve

The hydraulic power packs are fitted with a pressure valve which is factory set to prevent excess pressure in the power pack. If the valve opens, it is no longer possible to lift the load. The load remains stationary. However, lowering (or releasing) is possible by operating the reverse operating lever either manually or by using the rams.

8.2.3 Thermal protection device

The electric motor of the hydraulic power pack is fitted with a thermal cut-out. Should the motor overheat, it will stop. Allow the motor to cool down before starting again. Should this happen several times, consider additional means of ventilation to cool the motor.

9. REPLACING THE SHEAR PINS

Figures 22 and 23 show the position of the shear pins for the various models. Spare shear pins are in the stub of the forward operating lever for the model TU16H and in the rope release lever for the model TU32H. Remove the sheared pins with a suitable punch.

On the TU16H, remove the screw on the end of the crank and its washer and then remove the forward operating handle stub by using an extractor. Remove the sheared pins and clean the grooves for the pins. Refit the forward operating handle stub on the crank and align the grooves for the shear pins.

On the TU32H, align the holes of the upper and lower sections of the forward operating lever.

Position the spare shear pin(s) and drive it/them in with a hammer.

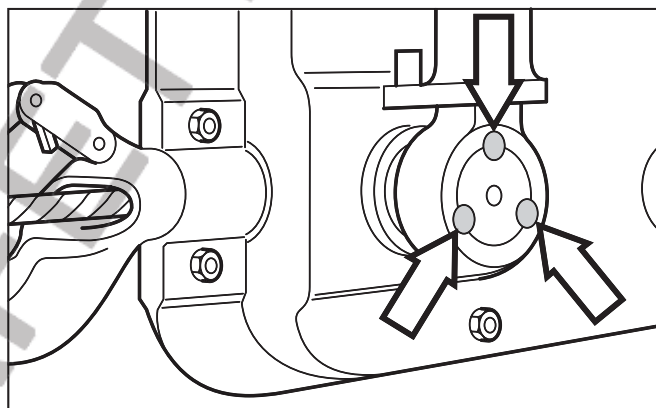

Fig. 22 - TU16H

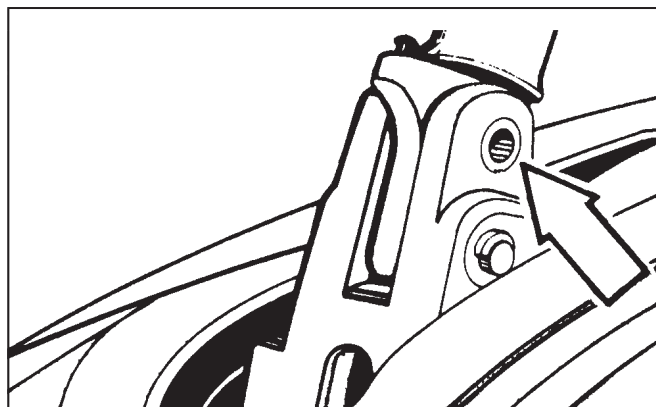

Fig. 23 - TU32H

⚠ Warning ⚠ : It is forbidden to replace sheared pins by anything other than genuine SUPERTIRFOR® shear pins of the same model.

Before putting the machine back into operation, ensure that the cause of the overload is removed. If necessary, use multiple sheave blocks (See Fig. 6).

Remember to re-order spare shear pins and put them back in the correct place.

10. WIRE ROPE

⚠ To guarantee the safe operation of SUPERTIRFOR® machines, it is essential to use them exclusively with SUPERTIRFOR® wire rope which has been specially designed to meet the requirements of the SUPERTIRFOR® machines. SUPERTIRFOR® wire ropes have a yellow strand which is visible on new rope.

One end of the wire rope has an end fitting, such as a safety hook, fitted to a thimble fixed by a metal ferrule (see Fig. 24). The other end of the wire rope is fused and tapered (see Fig. 22).

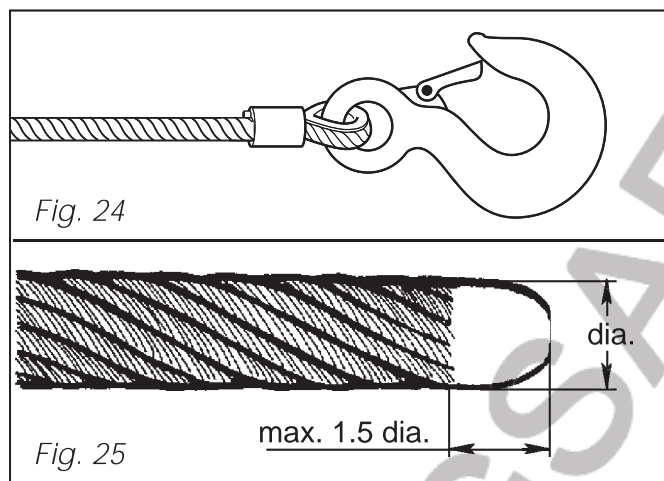

⚠ A wire rope in good condition is a guarantee of safety, to the same extent as a machine in good condition. It is necessary to continuously monitor the state of the wire rope, to clean and oil it with a rag soaked with motor oil or grease.

Grease or oil containing graphite additives or molybdenum disulphide must not be used.

Visual examination of the wire rope

The wire rope should be examined daily to detect any signs of wear (damage or broken wires : see examples in Fig. 26).

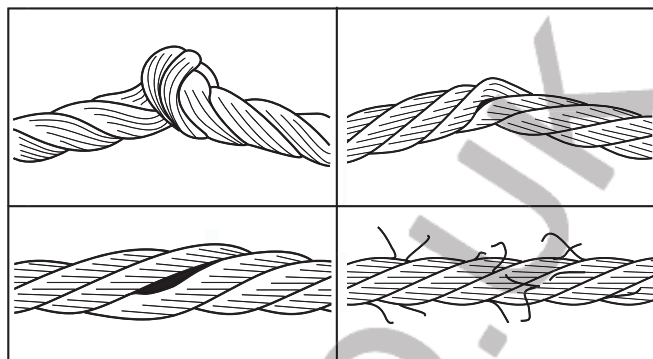
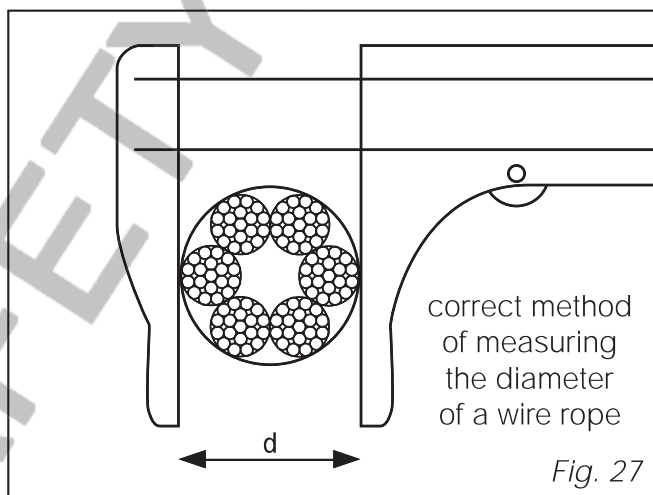

Fig. 26 - Examples of damaged wire rope

In case of any apparent wear, have the wire rope checked by a competent person. Any wire rope with a reduction from the nominal diameter by more than 10% should be replaced. (See Fig. 27 for the correct method of measuring the diameter of a wire rope.)



IMPORTANT : It is recommended, specially for lifting applications, to ensure that the length of wire rope is greater than actually required. Allow an extra meter approximately which should always go beyond the machine side case at the anchor point.

When lifting or lowering loads over long lengths of wire rope, steps should be taken to stop the load from rotating to prevent the wire rope from unlaying.

Never allow a tensioned wire rope to rub over sharp edges. The wire rope must only be used with pulleys of an appropriate diameter.

Never expose the wire rope to temperatures beyond 100° C.

Never use wire rope that has been subject to damage such as fire, corrosive chemicals or atmosphere, or exposed to electric current.

Storage : see section 7 : Taking out of service and storage.

11. MAINTENANCE INSTRUCTIONS

11.1. SUPERTIRFOR® machines

The machine should be inspected, cleaned and lubricated at regular intervals, at least annually, by an approved TRACTEL repairer.

Never use grease or oil containing graphite additives or molybdenum disulphide.

To clean the machine, allow it to soak in a bath of some proprietary cleansing fluid such as paraffin, petrol or white spirit but not acetone and derivatives or ethylene trichloride and derivatives. Then shake the machine vigorously to loosen foreign matter. Turn it upside down to allow the dirt to come out through the openings for the operating levers. Allow the mechanism to drain and become dry.

After this treatment, ensure that the machine is well lubricated by applying a quantity of oil (type SAE 90-120) onto the internal mechanism through the openings in the side cases as well as through the special lubrication hole for the TU16H. To carry out this procedure, it is best for the machine to be not under any load and in the released position and operate the forward and reverse operating levers to allow the lubricant to penetrate all parts of the mechanism.

11.2. Hydraulic power pack and hoses

The hydraulic power pack should be cleaned and inspected regularly, at least annually, by an approved TRACTEL repairer.

Fill the oil reservoir with hydraulic fluid leaving the filter in place at the entrance to the reservoir.

Check that the ball valves on the ram and hoses are clean. These are fitted with dust covers for each hose connection, which should be refitted each time the hose is disconnected.

Where there is a high level of operation, it is recommended to change the hydraulic fluid every 6 months. For less frequent operation, the oil change should be every year.

To empty the reservoir of the hydraulic power pack, remove the screw which is underneath the reservoir itself. Dispose of the old hydraulic oil appropriately.

DO NOT THROW THE HYDRAULIC OIL AWAY OR POUR IT DOWN THE DRAIN.

The drain screw comprises a magnetic section to recover the metal particles.

CLEAN THE DRAIN SCREW FULLY BEFORE REPLACING IT IN ITS HOUSING.

Check that the drain screw is correctly fitted before refilling the reservoir with hydraulic fluid.

12. ⚠️ WARNINGS AGAINST HAZARDOUS OPERATIONS ⚠️

The operation of SUPERTIRFOR® machines, in accordance with the instructions of this manual, is a guarantee of safety. Nevertheless, it is useful to draw the attention of users to the following warnings :

- Never connect a TU16H to an output of 13 l/min.
- Never allow an electric motor to rotate anti-clockwise.
- Never allow a hydraulic power pack to operate without hydraulic fluid in the reservoir.
- Never connect more than four hydraulic rams to a power pack.
- Never connect a hydraulic power pack with electric motor to a power supply without correct earthing.
- Never smoke near a hydraulic power pack with petrol engine whilst the fuel tank is being filled.
- Never refill the fuel tank whilst the power pack is running.
- Never use a fuel other than that recommended.
- SUPERTIRFOR® machines as described in this manual must not be used for lifting people.
- SUPERTIRFOR® machines must not be used beyond their maximum working load.
- SUPERTIRFOR® machines must not be used for applications other than those for which they are intended.
- Never attempt to operate the rope release mechanism whilst the machine is under load.
- Never obstruct the operating levers or the rope release lever.
- Never operate the forward and reverse operating levers at the same time.
- To operate the SUPERTIRFOR® machine, never use anything other than the hydraulic ram or the telescopic operating handle supplied.
- It is forbidden to replace sheared pins by anything other than genuine SUPERTIRFOR® shear pins of the same model.

- Never anchor the machine other than by its appropriate anchor point.
- Never obstruct the machine, which could prevent the machine, the wire rope and the anchor points from operating in a straight line.
- Never use the wire rope as a sling.
- Never apply a load to the loose wire rope exiting from the anchor point of the machine.
- Never subject the controls to sharp knocks.
- Never attempt to reverse the wire rope completely through the machine whilst under load.
- Do not operate the SUPERTIRFOR® machine when the rope ferrule gets to within 10 cm of the machine. Otherwise the ferrule is likely to foul the casing and push the rope guide inside the machine.
- Never put the telescopic operating handle on the forward or reverse operating lever when the ram is fitted to the SUPERTIRFOR® machine.

13. TROUBLESHOOTING

- 1) The forward operating lever moves freely** and does not operate the mechanism : the machine has been overloaded and the shear pins have sheared. See section 9 for replacing the shear pins.
- 2) Pumping** : a lack of lubricant in a machine sometimes brings about a condition known as "pumping" which is not at all dangerous, but which is inconvenient. This situation occurs when the jaw which is gripping the rope becomes locked onto it preventing the other jaw from taking over the load. As the operating lever is moved in one direction the machine travels a few centimeters, but when the operating lever travels in the other direction the machine moves back the same distance in sympathy with the jaw which is locked onto the rope. The machine should be thoroughly lubricated and it will recommence working normally.
- 3) Jerkiness** : this is also a symptom of lack of lubrication. The machine should be thoroughly lubricated.
- 4) Blockage** : if the wire rope becomes blocked in the machine, generally because a damaged section of wire rope is stuck within the jaws, it is imperative to stop operating the machine. The load should be taken by another machine on a separate wire rope, or by another means, whilst ensuring that all safety precautions are

taken. When the blocked machine is no longer under load, the damaged rope may be released and removed. Should this not be possible, return the machine and wire rope to a TRACTEL approved repairer.

- 5) The electric motor turns in the wrong direction** : should this occur there is a risk of very quickly damaging the hydraulic pump. Stop the power pack, disconnect the mains power supply. Reverse two phases in the power supply plug by using a screw driver. This should be carried out by a qualified electrician.
- 6) Not enough hydraulic oil in the reservoir** : Refill the oil reservoir with hydraulic fluid up to the middle of the upper sight glass.
- 7) The flow regulator shows the maximum pressure and the rams do not operate** : the maximum capacity has been reached. In systems with 2, 3 or 4 machines, if one of the machines exceeds the maximum capacity, the whole system stops. Reduce the load or spread the load more evenly over each of the machines.
- 8) The electric motor starts with difficulty** : check that the 3 phases of the power supply are correctly connected to the power pack and that the mains power supply itself is correct for the power pack. This should be carried out by a qualified electrician.

14. HEALTH AND SAFETY AT WORK

It is the responsibility of every company to ensure that their employees have been fully and properly trained in the safe operation of their equipment.