

Dimensions model CPA

Model	CPA 1-13	CPA 2-10	CPA 2-31	CPA 5-5	CPA 5-17	CPA 10-9
A, mm	292	292	457	324	457	457
A1, mm	410	410	483	410	483	508
B, mm	21	21	25	14	25	27
C, mm	20	20	24	24	24	28
D, mm	16	16	26	14	26	28
F1, mm	90	90	130	90	130	130
F2, mm	120	120	180	120	180	180
K, mm	103	103	146	103	146	165
L, mm	57	57	102	57	102	83
M, mm	120	120	114	120	114	135
N, mm	50	50	54	50	54	25
Q1, mm	142	142	162	142	162	162
Q2, mm	183	183	181	183	181	181

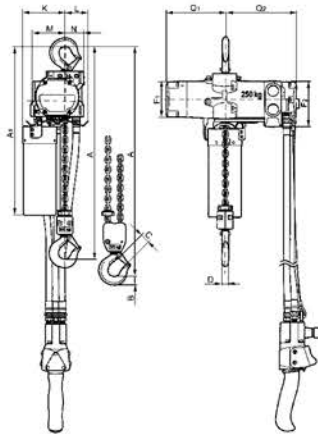

Model CPA 1-13 / 2-10 / 5-5

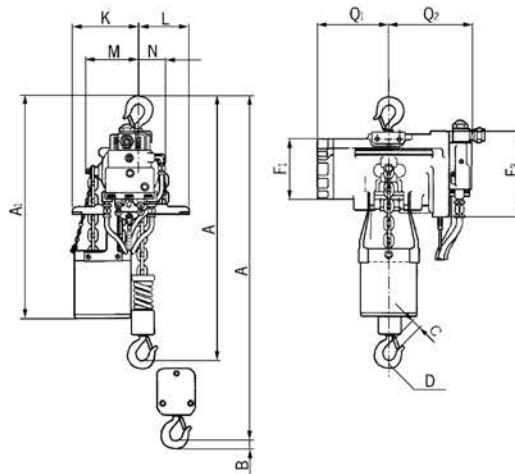

Model CPA 2-31 / 5-17 / 10-9

# Hoisting Equipment Pneumatic chain hoists

## Dimensions model CPA

Model	CPA 20-8	CPA 30-6	CPA 40-4	CPA 50-3	CPA 60-3	CPA 75-2	CPA 100-3
A, mm	516	516	681	681	681	950	1068
A1, mm	286	286	428	428	428	479	651
B, mm	35	35	45	45	47	60	60
C, mm	37	37	46	46	42	52	52
D, mm	24	24	30	30	30	40/45	40/45
F1, mm	160	160	160	160	160	160	160
F2, mm	165	165	165	165	165	165	165
G, mm	220	220	220	220	220	220	581
G1, mm	180	180	140	140	140	268	311
G2 (13 m), mm	258	258	218	218	218	-	-
G2 (21 m), mm	278	278	238	238	238	345	408
H1, mm	110	110	110	110	110	110	110
H2, mm	135	135	135	135	135	307	256
H3, mm	115	115	115	115	115	115	115
K1, mm	100	100	100	100	100	92	92
K2, mm	51	51	51	51	51	62	62
M, mm	50	50	9.6	9.6	9.6	139	181
N, mm	60	60	100	100	100	136	291
Q1, mm	272	272	272	272	272	272	272
Q2, mm	325	325	325	325	325	325	325

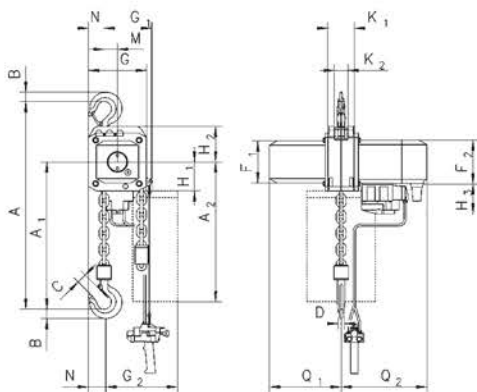

Model CPA with suspension hook, 2000 - 3000 kg, single fall

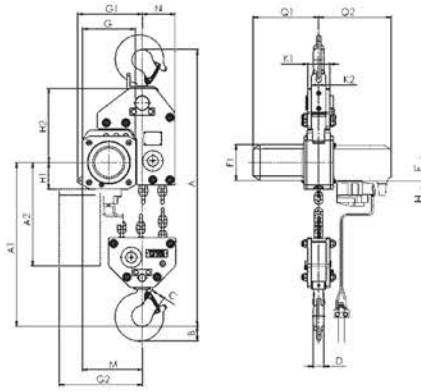

Model CPA with suspension hook, 7500 kg, three fall

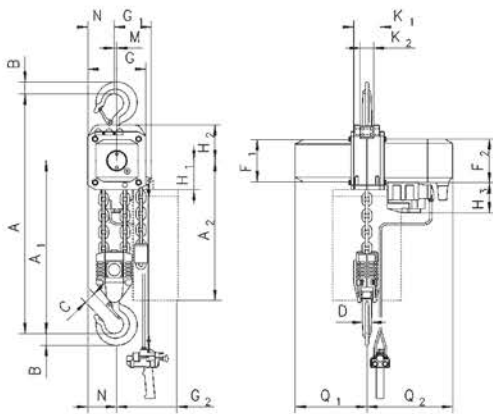

Model CPA with suspension hook, 4000 - 5000 kg, double fall

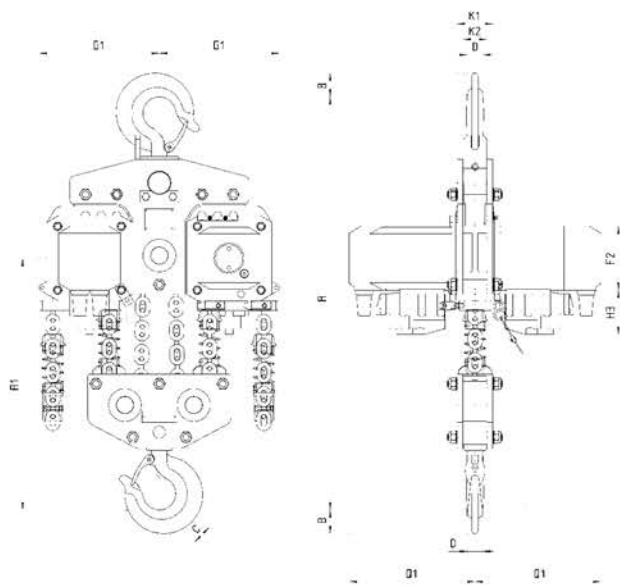

Model CPA with suspension hook, 10000 kg, four fall

Dimensions model CPA

Model	CPA 20-8	CPA 30-6	CPA 40-4	CPA 50-3	CPA 60-3	CPA 75-2	CPA 100-3
A2 (13m), mm	430	430	430	430	430	-	-
A2 (21m), mm	530	530	530	530	530	530	530
A4, mm	465	465	615	615	615	855	965
A5, mm	298	298	298	298	298	477	425
A6, mm	190	190	190	190	190	182	182
b, mm	A = 98 - 180/ B = 180 - 300	A = 98 - 180/ B = 180 - 300	A = 98 - 180/ B = 180 - 300	A = 98 - 180/ B = 180 - 300	A = 98 - 180/ B = 180 - 300	125 - 310	125 - 310
F, mm	150	150	150	150	150	113	113
I, mm	142.5	142.5	142.5	142.5	142.5	130	130
L1, mm	209	209	209	209	209	200	200
L2, mm	262.5	262.5	262.5	262.5	262.5	215	215
L3, mm	265	265	265	265	265	265	265
L4, mm	213	213	253	253	253	291	291
L5, mm	312	312	272	272	272	-	-
L6, mm	315	315	275	275	275	-	-
O, mm	125	125	125	125	125	150	150
P, mm	208	208	208	208	208	208	208
P1, mm	284	284	284	284	284	284	284
S, mm	b + 70	b + 70	b + 70	b + 70	b + 70	b + 98	b + 98
t, mm	27	27	27	27	27	40	40
T1 size A	182	182	182	182	182	-	-
T1 size B	242	242	242	242	242	270	270

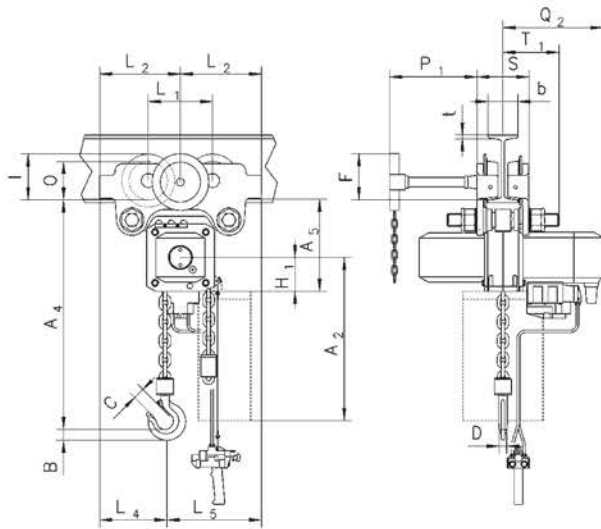

Model CPA with integrated manual push or geared trolley

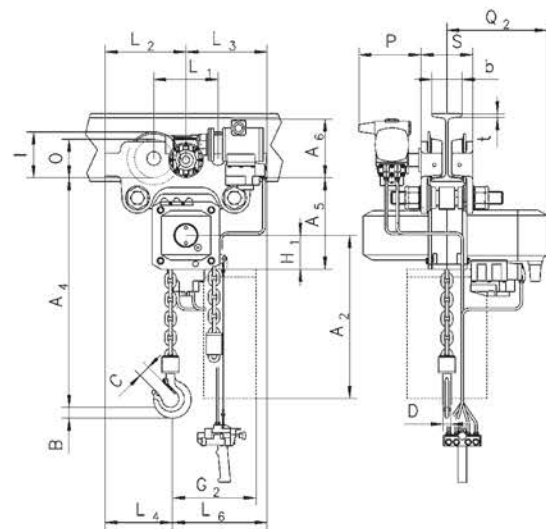

Model CPA with integrated pneumatic trolley