



SELBY ENGINEERING A DIVISION OF YALE LIFTING SOLUTIONS TEL: 01977 684 600



Manual, electric and pneumatic wire rope winches

Yale wire rope winches series MWS, MWW, RPE and RPA are designed explicitly for performance, efficiency and safety and offer many advantages and options.

RPE's and RPA's extremely compact, practical cube design and universal rope lead-offs allow individual applications in almost any position and make them powerful aids for lifting and pulling loads.

The winches are designed to DIN 15020, classification 1Bm, safety regulation BGV D8 (winch, lift and pull equipment) and, of course, the EC machinery directives.

MWS and MWW manual winches are characterized by an automatic load pressure brake for safe holding and extremely sensitive lowering of the load. Unintentional brake release is prevented even with swinging loads. They have a self-locking, back stroke proof, adjustable crank handle for fast lifting of smaller loads, resulting in lowest possible handle effort and rapid winding of the rope. They are suitable for operation in ambient temperatures of -20° through +40°C and manufactured in compliance with the German Safety Regulations for Winches, Lifting and Pulling Equipment BGV D8. Every winch is factory tested with overload.

The units are supplied with a test certificate showing the unit's serial-no. and an operating instructions manual which contains a manufacturer's declaration.

Manual wire rope winch

MWS
MWW

Manual wire rope winch with spur gear drive model MWS

Capacities 125 - 2.000 kg

- Enclosed gear drive for protection of internal parts, even under tough working conditions
- Spur gears on roller bearings, rope drum on plain bearings
- Compact design
- Easy and quick mounting onto walls, poles, towers etc.

Optional

- Corrosion protected design
- Grooved rope drum for improved guidance of the wire rope
- Separation webs for operation with several wire ropes



Manual wire rope winch with worm gear drive model MWW

Capacities 250 - 5.000 kg

- Worm shaft on roller bearings, rope drum on plain bearings
- Small dimensions, compact design, larger rope take-up
- Two rope directions for operation from different positions
- Two lifting speeds by means of different setting of the crank handle for capacities of 2.000 kg and above
- Automatic load pressure brake for safe holding and extremely sensitive lowering of the load

Optional

- Free wheeling device for quick unwinding of the unloaded wire rope for capacities of 2.000 kg and above



Model	Pulling force 1 st rope layer daN	Pulling force top rope layer daN	Crank effort 1 st rope layer daN	Rope advance per one crank rotation 1 st rope layer 1 st /2 nd speed in mm	Ratio	Weight without wire rope kg	Recommended rope diametre* mm
MWS 125	125	55	11	120	1:1	7	3
MWS 300	300	120	7	21	1:7,4	10	5
MWS 500	500	323	13	30	1:7,4	11	6
MWS 1000	1000	684	15	21	1:17	28	9
MWS 2000	2000	1712	24	16	1:25,7	32	13
MWW 250	250	95	5	17/-	1:10	13	5
MWW 500	500	239	9	20/-	1:12	16	6
MWW 1000	1000	542	14	13/-	1:26	26	9
MWW 1500	1500	845	21	13/-	1:26	28	10
MWW 2000	2000	1129	12/20	5,5/11	1:76/38	60	13
MWW 3000	3000	1861	17/30	5/10	1:104/52	78	16
MWW 5000	5000	3165	34/61	6/12	1:120/60	115	20

*acc. DIN 3060 FE-znk 1770sZ-spa

Model	Breaking load of wire rope min. kN	Wire rope storage max. m	Number of rope layers max.
MWS 125	5,7	52	18
MWS 300	15,9	26	9
MWS 500	22,9	12	5
MWS 1000	51,0	27	5
MWS 2000	106,0	7	2
MWW 250	15,9	63	11
MWW 500	22,9	77	9
MWW 1000	51	55	7
MWW 1500	63	49	6
MWW 2000	106	46	6
MWW 3000	161	52	5
MWW 5000	252	40	5

Dimensions MWS in mm

Dimension	MWS 125	MWS 300	MWS 500	MWS 1000	MWS 2000
A	70	200	200	230	230
B	305	300	300	340	340
C	270	268	268	280	280
D	-	168	168	180	180
G	40	15	15	27	27
H	85	60	60	126	126
ØJ	32	50	70	102	121
K	14	12	12	17	17
ØL	141	140	140	212	212
M	-	198	198	266	288
N	153	108	108	118	118
O	325	263	263	425	425
P	300	250	250	250	250
S	128	128	128	128	128

**Model MWS
with spur gear drive**
Capacity 125 kg

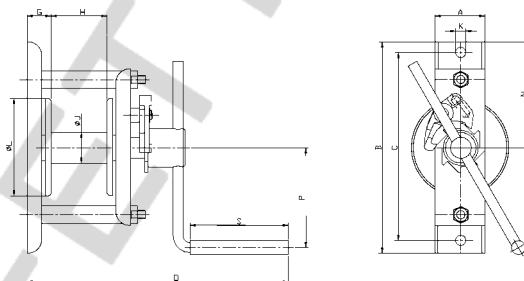

**Model MWS
with spur gear drive**
Capacities 300 - 500 kg

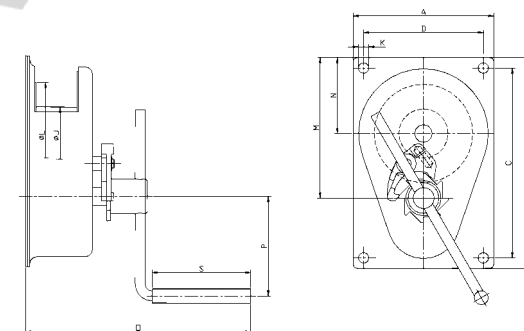

**Model MWS
with spur gear drive**
Capacities 1.000 - 2.000 kg

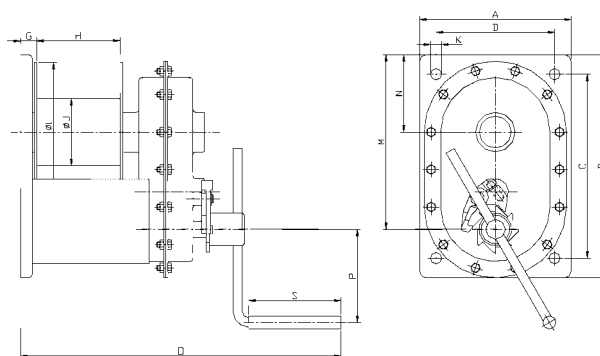

Dimensions MWW in mm

Dimension	MWW 250	MWW 500	MWW 1000	MWW 1500	MWW 2000	MWW 3000	MWW 5000
A	293	313	348	378	410	436	436
B	140	164	201	238	295	356	421
C	82	106	141	178	196	251	316
D	261	281	316	346	360	386	386
G	123	125	127	127	137	137	138
H	107	129	160	185	180	205	200
ØJ	48	70	102	102	133	165	219
K	17	17	17	17	25	25	25
ØL	160	190	240	240	312	376	437
M	121	138	164	164	208	260	298
N	88	96	140	142	249	308	335
O	410	440	490	490	740	825	865
P	350	350	350	350	380	380	380
R	170	190	260	263	419	550	613
S	140	140	140	140	250	250	250

**Model MWW
with worm gear drive**
Capacities 250 - 1.500 kg

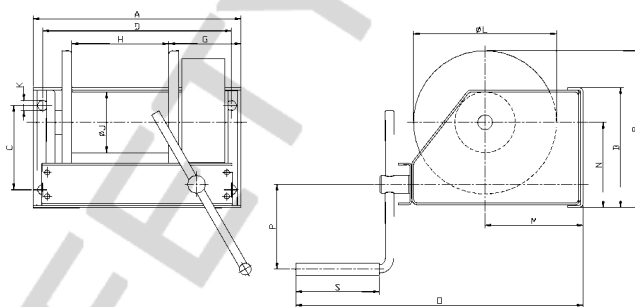

**Model MWW
with worm gear drive**
Capacities 2.000 - 5.000 kg

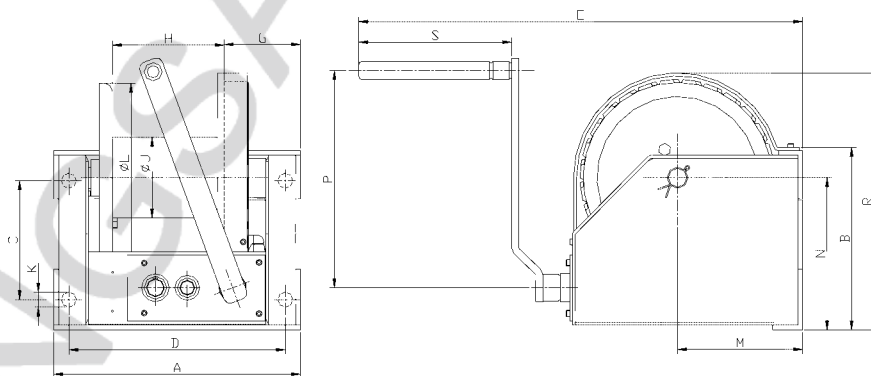

Yale[®]

Electric wire rope winch RPE



Electric wire rope winch model RPE

Features

- Compact dimensions due to internal brake motor, Standard: Euro-voltage 230/400 V, 50 Hz., 3-phase, protected to IP 54, Insulation class F.
- Adjustable slip clutch to protect the winch from overloading (1000 kg capacity only).
- Spur gear transmission with helical first gear ensures smooth motion. Lubricated by grease and can, therefore, be used in any position.
- Spring pressure disc brake incorporated in the motor holds the load secure even in the event of a power failure.
- Plain rope drum standard.
- The rope is secured to the drum in a recess so that the rope can be wound onto the drum in several layers without damage.
- Direct control as standard.



Rope attachment



Spring pressure disc brake



Gearbox with slip clutch
(1000 kg capacity)



Brake motor

Special design according to BGV C1
for theater stage applications available.

Technical Data

Model	Pulling force in the upper layer daN	Lifting speed m/min	Rope Ø mm	Motor performance kW	ED at 120 c/h %	Useable rope length in the upper layer in m	Weight without rope kg
RPE 2-13	250	13,0	4	0,55	40	54,5	31,8
RPE 5-6	500	6,5	6	0,55	40	38,8	32,8
RPE 5-12	500	12,0	6	1,10	40	55,4	41,0
RPE 9-6	990	6,0	8	1,10	40	37,4	76,0
RPE 10-6**	1000	6,0	8	1,10	40	37,4	76,9

**with slip clutch

Optional

- Different drum designs, e.g. extended to accommodate longer rope, machined grooves for exact reeling, with separation web and 2nd rope outlet for working with two ropes, traversing operation.
- Gearbox end switches to limit rope motion in both directions.
- Single-phase A.C. motor 230 V, 50 Hz, for mobile application of the winch.
- Control by means of pendant control including control switch with emergency stop and 2 m long control cable.
- Contactor control with 42 V control voltage when using end or slack rope switches.
- Slack rope switch to automatically stop the winch when rope tension eases e.g. when the load touches down.
- Frequency converter for stepless speed control.



Different drum designs



Single-phase A.C. motor



Geared limit switches

Plain standard drum (longer useable rope length)

Pulling force in all layers daN	Lifting speed upper layer m/min.	Drum size	Max rope length upper layer m
250	13,0	2	80
500	6,5	2	58
990/1000	6,0	2	56
250	13,0	3	200
500	6,5	3	140
500	12,0	3	140
990/1000	6,0	3	100

Grooved drum (larger drum diameter) only for single layer operation

Pulling force in all layers daN	Lifting speed upper layer m/min.	Drum size	1 st layer/m
250	13,0	1	8,6
500	6,5	1	5,8
990/1000	6,0	1	6,8
250	13,0	2	15
500	6,5	2	10,7
500	12,0	2	10,7
990/1000	6,0	2	12,7
250	13,0	3	44
500	6,5	3	31
500	12,0	3	31
990/1000	6,0	3	29

Pneumatic wire rope winch RPA

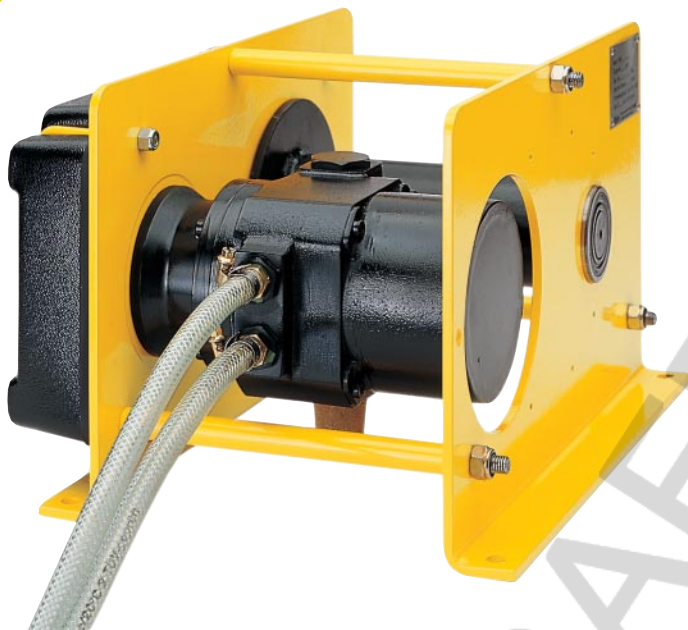

Pneumatic wire rope winch model RPA

With 100% duty rating and an unlimited number of starts the model RPA is suitable for heavy duty applications. It is insusceptible to contamination, humidity and aggressive mediums from the outside.

Features

- Robust rotating piston motor with high starting torque, designed for operating pressures 4 to 6 bar.
- Spring pressure disc brake incorporated in the motor holds the load secure even in the event of an air failure.
- Sensitive control by means of direct acting valves in the control switch.
- The conception is in accordance with the design of the model RPE but is not supplied with an emergency stop button.

Optional

- Different drum designs, e.g. extended to accommodate longer rope, machined grooves for exact reeling, with separation web and 2nd rope outlet for working with two ropes, traversing operation.

Technical Data

Model	Pulling force in the upper layer daN	Lifting speed with rated load* m/min	Lifting speed without load* m/min	Lowering speed with rated load* m/min	Useable rope length upper layer in m	Weight without rope kg
RPA 2-13	250	12,5	20,0	22,0	54,5	36,7
RPA 5-6	500	6,2	10,0	11,0	38,8	36,7

*Value for 6 bar, air consumption 0,75 m³/Min, motor performance 0,55 kW

To ensure faultless operation the compressed air supply must be filtered and oiled!

Dimensions RPE/RPA in mm

Dimension	RPE 2-13	RPE 5-6	RPE 5-12	RPE 9-6	RPE 10-6	RPA 2-13	RPA 5-6
A	405	405	405	525	525	405	405
B	375	375	375	485	485	375	375
C	18	18	18	25	25	18	18
D _{TR}	76	76	76	108	108	76	76
D _{max}	104	118	118	148	148	104	118
D _A	150	150	150	180	180	150	150
E	336	336	426	465	465	336	336
F	210	210	300	270	270	210	210
G	260	260	350	345	345	260	260
H	290	290	380	380	380	290	290
I	11	11	11	13	13	11	11
K	250	250	250	340	340	250	250
L	125	125	125	170	170	125	125
M	6	6	6	10	10	6	6
N	33,0	33,0	33,0	47,5	47,5	33,0	33,0
O	194	194	284	250	250	194	194
P	19	19	19	24	24	19	19
Q	13	13	13	19	19	13	13
R	125	125	125	170	170	125	125
S	4	6	6	8	8	4	6
α1	130°	130°	130°	145°	145°	130°	130°
α2	110°	110°	110°	125°	125°	90°	90°
α3	40°	40°	40°	50°	50°	20°	20°
β1	150°	150°	150°	155°	155°	150°	150°
β2	90°	90°	90°	100°	100°	70°	70°
β3	80°	80°	80°	83°	83°	60°	60°

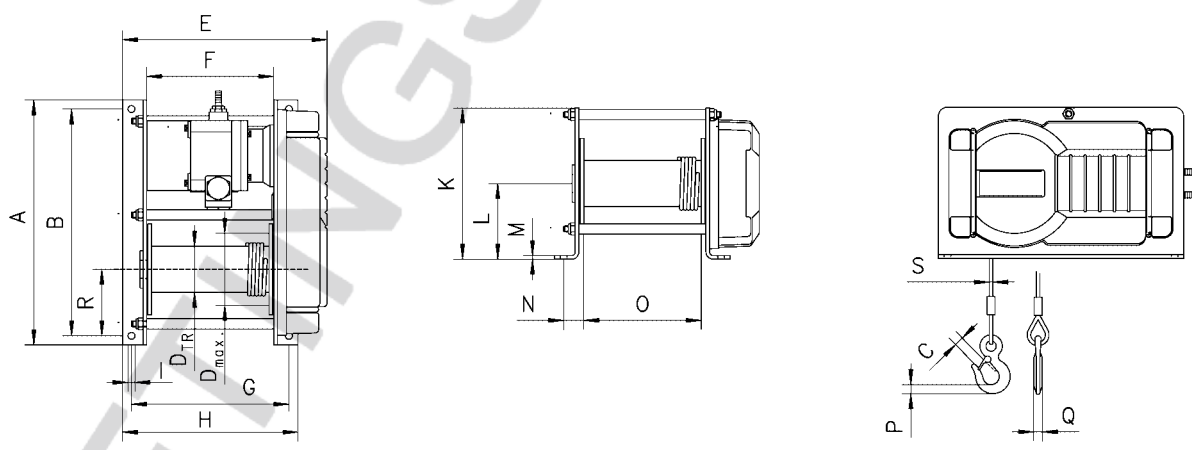

Rope lead-offs for **electric** rope winch RPE

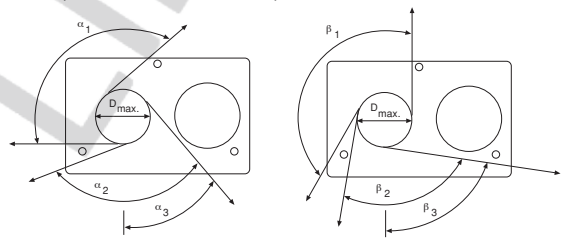

Rope lead-offs for **pneumatic** rope winch RPA

