

Yale

Electric Winch Model RPE

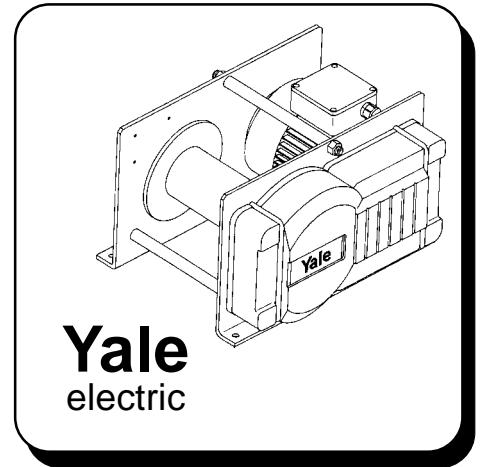

Capacity 250 kg - 1000 kg

RPE 2-13, RPE 5-6
RPE 5-12, RPE 9-6
RPE 10-6

Operating and Maintenance Manual Spare Parts Catalog

Yale

Yale Industrial Products GmbH

Postfach 10 13 24 • D-42513 Velbert, Germany
Am Lindenkamp 31 • D-42549 Velbert, Germany
Tel. 0 2051- 600-0 • Fax 0 2051-600-27

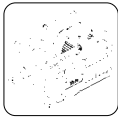

Yale Electric Wire Rope Winch

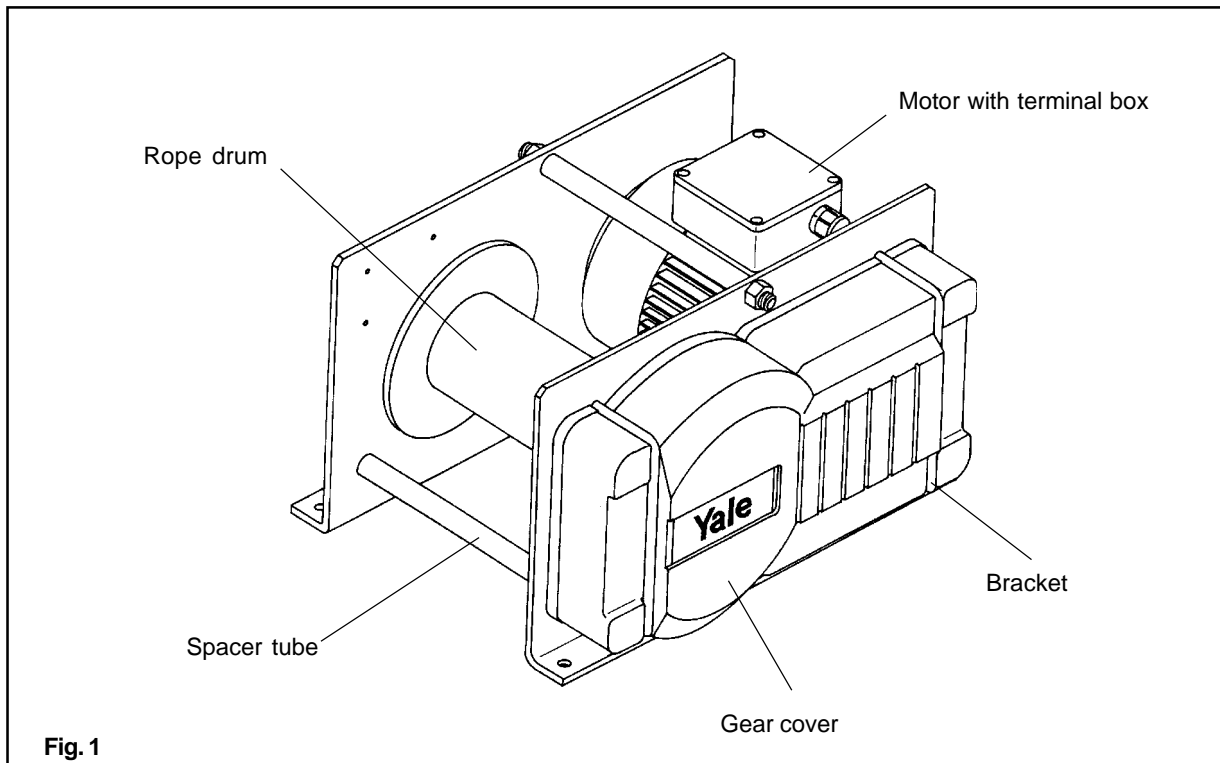
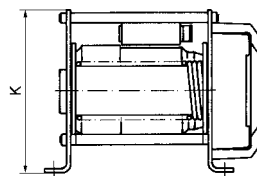
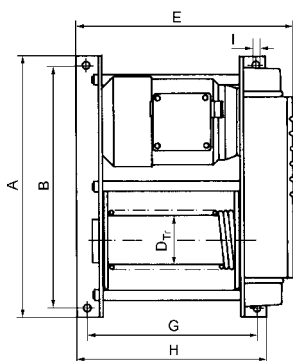

Fig. 1

Technical data

Model	Force* [daN]	Lifting speed* [m/min]	Rope diametre [mm]	Motor output [kW]	ED** [%]	Usable rope length [m]				Weight*** [kg]
						1 st Layer	2 nd Layer	3 rd Layer	4 th Layer	
RPE 2-13	250	13,0	4	0,55	40	11,2	24,4	38,8	54,5	31,8
RPE 5-6	500	6,5	6	0,55	40	7,0	16,4	27,0	38,8	32,8
RPE 5-12	500	12,0	6	1,10	40	11,0	24,9	39,7	55,4	41,0
RPE 9-6	990	6,0	8	1,10	40	10,2	23,0	37,4	-	76,0
RPE 10-6	1000	6,0	8	1,10	40	10,2	23,0	37,4	-	76,9

* in top layer; ** at 120 c/h; *** without rope



Dimensions in mm

Model	A	B	D _{Tr}	E	G	H	I	K
RPE 2-13	405	375	76	336	260	290	11	250
RPE 5-6	405	375	76	336	260	290	11	250
RPE 5-12	405	375	76	426	350	380	11	250
RPE 9-6	525	485	108	465	345	380	13	340
RPE 10-6	525	485	108	465	345	380	13	340

other dimensions see catalog page 30

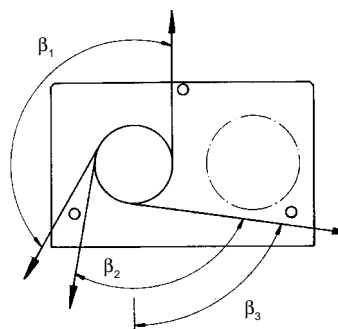
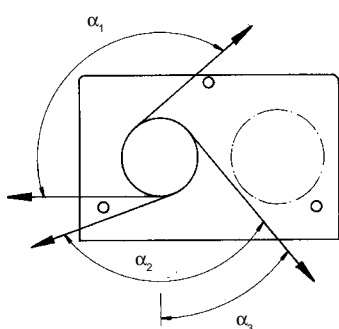

Rope Lead-Offs

Model	α_1	α_2	α_3	β_1	β_2	β_3
RPE 2-13	130°	110°	40°	150°	90°	80°
RPE 5-6	130°	110°	40°	150°	90°	80°
RPE 5-12	130°	110°	40°	150°	90°	80°
RPE 9-6	145°	125°	50°	155°	100°	83°
RPE 10-6	145°	125°	50°	155°	100°	83°

Contents

1. INTRODUCTION	3
2. OPERATING INSTRUCTIONS	3
2.1 Correct Operation	3
2.2 Incorrect Operation	4
3. ASSEMBLY / COMMISSIONING	4
3.1 Inspection prior to commissioning	4
3.2 Commissioning	4
3.3 Electrical connections	5
3.4 Fitting the wire rope	5
3.5 Function test after assembly	5
4. OPERATION	6
5. SERVICE	6
5.1 Servicing and inspecting the wire rope	6
5.2 Servicing the gearbox	6
5.3 Servicing the motor	7
5.4 Adjusting the slip clutch	7
5.5 Adjustment of limit switch (optional equipment)	7
INSPECTION CHART	7
INSPECTION RECORD	8
SPARE PARTS LISTS	9 - 15
WIRING DIAGRAMS	16 - 18
MANUFACTURER'S DECLARATION	19

1. INTRODUCTION

Attention: All users must read these operating instructions carefully prior to initial operation. These instructions are intended to acquaint the user with the electric winch and enable him to use it to the full extent of its intended capabilities.

The operating instructions contain important information on how to handle the electric winch in a safe, correct and economic way. Acting in accordance with these instructions helps to avoid dangers, reduce repair costs and down time and to increase the reliability and lifetime of the electric winch. These operating instructions have to be always available at the place where the winch is used. Anyone involved in doing any of the following work with the electric winch must read the operating instructions and act accordingly:

- operation, including preparation, trouble shooting during operation and cleaning maintenance
- inspection and repair and / or
- transport

Apart from the operating instructions and the accident prevention act valid for the respective country and area where the winch is used, also the commonly accepted regulations for safe and professional work must be adhered to.

Every unit is furnished with a test certificate that shows the serial number of the winch. This certificate should be stored with the inspection record (see page 19).

The continuous sound level at the place of work is equal to 72 dB. The measurements were taken at a distance of 1 m from the winch at 9 positions in accordance with DIN 45635 precision class 2.

2. OPERATING INSTRUCTIONS

2.1 CORRECT OPERATION

Max. capacity

- The Yale electric winch RPE is designed to pull, lift and lower loads up to the rated capacity. The lifting/pulling capacity indicated on the winch is the maximum safe working load which must not be exceeded. Furthermore the max. lifting/pulling capacity is dictated by the technical data of the wire rope used and the method of attachment.

Danger Zones

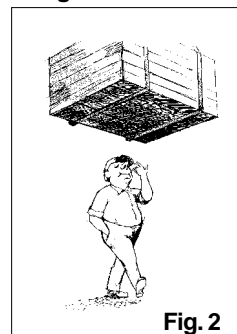
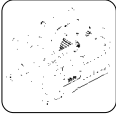

Fig. 2

- Do not lift or transport loads while personnel are in the danger zone.
- Do not allow personnel to pass under a suspended load (Fig. 2).
- After lifting or tensioning, a load must not be left unattended for a longer period of time.
- Start moving the load only after it has been attached correctly and all personnel are clear of the danger zone.



Temperature range

• The winches can be operated in ambient temperatures between -20° C and +40° C. At temperatures below 0° C the brake should be checked for freezing. Consult the manufacturer in case of extreme working conditions.

Regulations

• The accident prevention act and safety regulations of the respective country for using electric winches must be strictly adhered to.

Maintenance / Repair

• In order to ensure correct operation not only the operating instructions, but also the conditions for inspection and maintenance must be complied with. If defects are found stop using the winch immediately.

2.2 INCORRECT OPERATION

Among others following are examples of incorrect practises:

- Exceeding the rated capacity of the winch.
- Using the winch for the transportation of people (Fig. 3).
- Welding on the hook and wire rope is strictly forbidden. The wire rope must never be used as a ground connection during welding (Fig. 4).
- The wire rope must not be used for lashing purposes (Fig. 5).
- Do not knot or shorten the wire rope by using clamps, screws, screwdrivers or other devices (Fig. 6). Do not use the wire rope over sharp edges.
- Removing the safety latch from the load hook.
- Avoid side-pull on the hook or housing. See page 2 for rope lead-offs.

3 ASSEMBLY / COMMISSIONING

3.1 INSPECTION PRIOR TO COMMISSIONING

Each winch must be inspected prior to the initial operation by a competent person. The inspection is visual and functional and shall establish that the winch is safe and has not been damaged by incorrect transport or storage. Inspections should be made by a representative of the manufacturer or the supplier although the company can assign its own suitably trained personnel. Inspections are instigated by the user.

3.2 COMMISSIONING

- Before assembling the winch ensure that the surface to which the winch is to be mounted (e.g. wall, concrete floor, steel construction etc.) is suitable to accept all working forces.
- The winch is retained by 4, property class 8.8, screws. For tightening force see following table:

Model	Screw	Tightening torque [Nm]
RPE 2-13 RPE 5-6 RPE 5-12	M10	49
RPE 9-6 RPE 10-6	M12	85

- The mounting surfaces must be flat and parallel so that the winch feet make even contact with the surface. The winch must be securely mounted so it cannot move when under load.
- The winch can be fitted in any position, but the rope drum must always be horizontal. Allowable reeling angles and directions are shown on page 2. The wire rope must be kept a safe distance away from sharp edges such as frames or walls. If a pulley block is used it must be positioned so that rope deflection is not more than 4°, if possible less than 1,5° (see Fig. 7 and 8).
- When mounting the winch consider the operator's position and ensure that he is not exposed to dangers from the winch, rope or load.

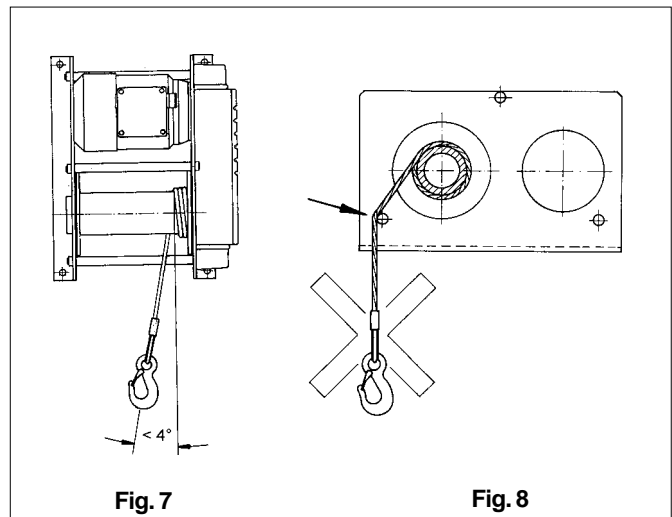
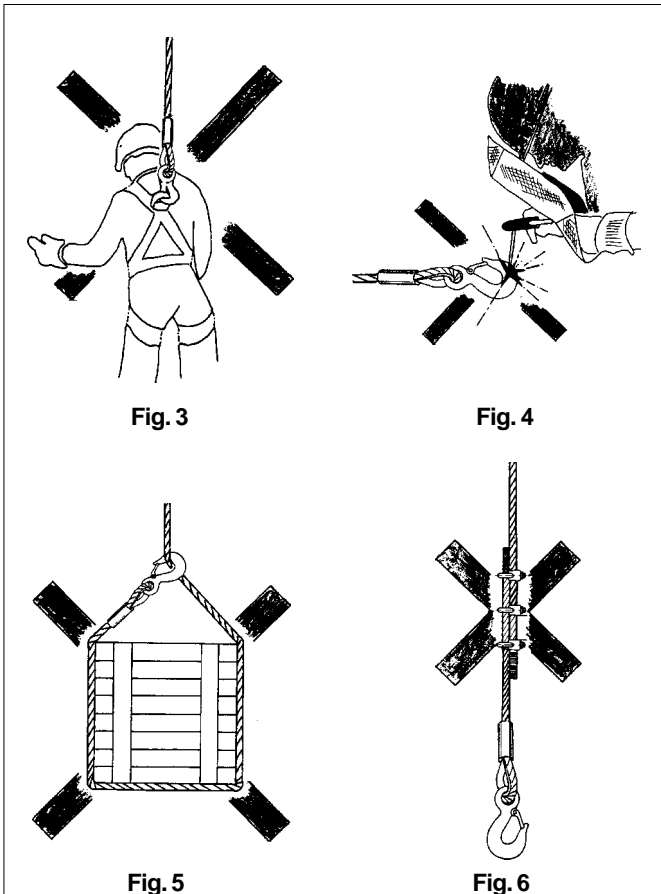

3.3 ELECTRICAL CONNECTIONS

Attention!

Work on electrical equipment may only be carried out by trained and certified tradesmen. The local regulations e.g. DIN 7100/VDE 0100 and DIN 57113/VDE 0113 resp. VDE 0105 and IEC 364 apply.

- Before beginning work on electrical components the main current switch must be switched off and secured against unintentionally being switched on. Test and ensure that the system is electrically dead.
- Before connecting the winch ensure that the electrical data on the nameplate match the local specifications.

Mains supply

The mains supply cable must be an insulated cable with 4 flexible leads. The ground (earth) lead must be longer than the live leads. For wire cross-section and fusing see bottom table. Use sleeves on the lead ends.

Connections are to be made according to the wiring diagram in the terminal box or as shown in the operating instructions.

Attention: The winch must be completely wired before it is connected to the mains supply.

Connecting the pendant control

The length of the pendant control cable is determined by the working conditions. Use sleeves at the lead ends. Attach the support wire in a manner that the pendant control cable hangs load-free.

Check the motor's direction of rotation

The wiring diagram included has been drawn for a normal, clockwise rotating installation. Should the user's mains supply not fulfil these requirements, e.g. winch lowers when lift is selected (or vice versa) switch the unit off immediately and exchange two of the three phase connections in the mains connection.

Under no circumstances may the wiring in the pendant control be tampered with!

3.4 FITTING THE WIRE ROPE

- Only unsheathed wire ropes with a minimum breaking strength of 1770 N/mm² in accordance with DIN 3051 may be used. If the load will be free to rotate use a low-twist wire rope e.g. in accordance with DIN 3069-SE.
- Before fitting the wire rope unreel it completely so it lies straight and uncoiled on the floor. This will prevent the wire rope from being pinched or twisted open when it is reeled onto the rope drum.

- To connect the wire rope enter the rope end into the bore in the rope drum and push it through to the end. Enter copper washers (item 25, page 9) between screws and rope and tighten the retaining screws to the torque shown in the table below.

Model	Screw	Tightening torque [Nm]
RPE 2-13 RPE 5-6 RPE 5-12	M6	8,3
RPE 9-6 RPE 10-6	M8	20

- The rope must be fitted so that it will not kink when unreeled (see Fig. 9).
- Wind the wire rope tightly onto the rope drum. Ensure that

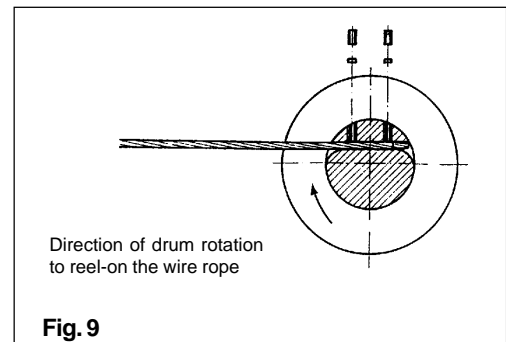

it is not kinked or interwinded.

- Wire length should be such that at least 2,5 turns of rope always remain on the drum.
- Lubricate the wire rope over its complete length with a suitable lubricant.

3.5 FUNCTIONTEST AFTER ASSEMBLY

Before operating the winch check following items:

- Are all connections and retaining screws tight and secure?
- Is the wire rope wound tightly and evenly, without kinks and interwinds, onto the drum?

Then unwind and rewind the wire rope over its complete length unloaded.

Motor data and fuses

Model	P _n [kW]	ED [%]	I _g /I _n	I _n [A]	Fuse (slow) A	Wire cross-section in mm ² for supply cables of length 0-150 m
RPE 2-13, RPE 5-6	0,55	40		1,8	10	1,5
RPE 5-12, RPE 9-6, RPE 10-6	1,1	40		3,0	10	1,5

all data for 400 V, 3-phase, 50 c/s

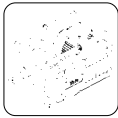

- Is the wire rope always a safe distance away from sharp corners?
- Do the directions of motion of the wire rope correspond with markings on the controls?
- When the wire rope has been completely unwound - do at least 2,5 turns of rope remain on the drum?
Then unwind and rewind the wire rope over its complete length loaded.
- The braking distance should not be more than 50 mm.
- The winch must remain in position under load.

4 OPERATION

Decisive for the operation and service of the winch are VBG 8 "Winches, Lifting and Pulling units" and the valid national regulations of the user's country.

Users delegated to install, service or independently operate the winch must have had suitable training and be competent. Users are to be specifically nominated by the company and must be familiar with all relevant safety regulations. The operating instructions are to be made available to these people.

Special attention should be given to following safety requirements:

- The max. lifting/pulling capacity of the winch, carrying devices and accessories must never be exceeded.
- Before using the winch check all safety limit switches and visually check the winch, carrying devices and accessories for signs of damage or wear.
- Ensure, before starting to lift a load, that the load has been attached correctly and that no personnel are in the danger zone.
- The winch is not designed for passenger transportation and should not be used for this purpose.
- Do not use the slip clutch (RPE 10-6 only) as an operational rope end-stop.
- There must always be at least 2,5 turns of wire rope on the rope drum.

The Yale electric wire rope winch conforms to machinery group 1 Bm in accordance with FEM 9.511. This results in a theoretical service lifetime of 400 operating hours under full load. Depending on the load spectrum the table below defines how many hours per day the winch can be used. This is equivalent to 10 years service under normal operating conditions. After this period the winch requires a general overhaul. Further information is contained in VBG 9 resp. FEM 9.755.

5. SERVICE

According to national and international safety regulations hoisting equipment must be inspected at least once annually by a competent person. Adverse working conditions, e.g. heat or chemical environments, can dictate shorter inspection periods. Repairs may only be carried out by specialist workshops that use original Yale spare parts.

The components of the winch are to be checked for damage, wear, corrosion or other irregularities and all safety devices for completeness and effectiveness.

5.1 SERVICING AND INSPECTING THE WIRE ROPE

For safety reasons the wire rope must be replaced when the total of broken wires in the outside strands exceeds a pre-defined number. The number of broken wires is to be counted over a distance of 6 resp. 30 times the rope diameter. The wire rope must be replaced immediately if a complete strand is broken or if the rope is deformed, kinked, buckled or is in any other way damaged or worn.

Decisive for the operation and service of the winch are VBG 8 "Winches, Lifting and Pulling units" and the valid national regulations of the user's country.

5.2 SERVICING THE GEARBOX

To service the gearbox first remove the gearbox cover (item 12, page 9) by removing the nuts (item 11) and brackets (item 10).

Check following items:

- Cover and U-profile rubber seal for damage and cracks.
- Gears for wear and cracks.
- Circlips for safe seat.

After checking the gearbox it must be re-lubricated. We recommend graphite grease Klüber Grafloscon A-G1 Ultra or Reiner Chemie Ceplattyn 300.

Table 1: Defining the average daily operating time

Load spectrum		average operating time [hours/working day]
light	small partial load, small deadload	1 - 2
medium	large partial load, medium deadload	½ - 1
heavy	large deadload	¼ - ½
very heavy	very large deadload	up to ¼

5.3 SERVICING THE MOTOR

• Motor

Under normal conditions the motor is practically service-free. Every 2½ years the bearings are to be inspected, cleaned and repacked with grease. We recommend K 3 N, KL 3 N, DIN 51825/DIN 51502.

• Disc brake

Service to the disc brake is reduced to checking and adjusting the brake air gap.

• The disc brake air gap δ should be between 0,2 and 0,4 mm. To reduce the air gap the brake ventilator must be moved axially along the shaft towards the motor. Place a suitable bush over the shaft and, using a screw, press the ventilator onto the shaft until the required measurement is achieved. Compensate the space between ventilator hub and the circlip on the motor shaft with spacer washers.

Achtung: Do not allow the brake friction pads to come into contact with lubricant or similar.

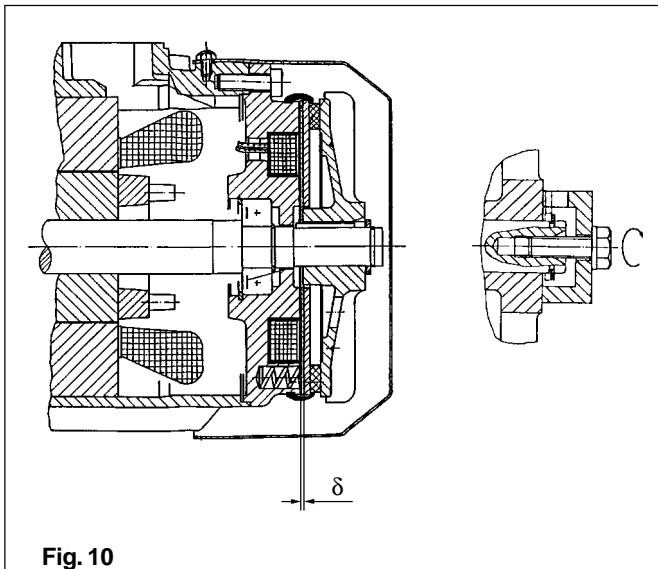

Fig. 10

5.4 ADJUSTING THE SLIP CLUTCH

The factory setting of the slip clutch is 110% +/- 10% of the rated capacity. The adjustment can be verified by lifting a load of this value. If the clutch slips with a rated capacity load it can be adjusted as follows (see Fig. 13):

- Remove the cover.
- Increase the clutch friction by tightening the nut (35) in a clockwise direction.
- Verify the adjustment by lifting a test load.

5.5 ADJUSTMENT OF LIMIT SWITCH (optional equipment)

To adjust the limit switch remove the limit switch protective cover. Operate the electric winch until it reaches the desired position. Loosen the adjustment locking screw in the centre of the cam block (see Fig. 11). Rotate the adjustment screw 1 or 2 until the cam operates the microswitch. Tighten the adjustment locking screw. Operate the electric winch to the second end position. Loosen the adjustment locking screw once again and rotate the other adjustment screw until the cam operates the microswitch. When the adjustment has been completed refit the limit switch protective cover.

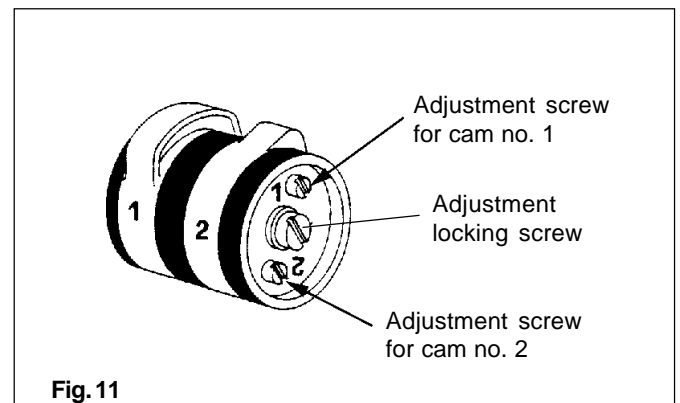
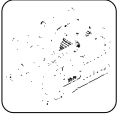

Fig. 11

Inspection chart

Inspection resp. service	Initial inspections		Periodical inspections	
	at commissioning	after 3 months	after 3 months/ 50 op. hours*	after 12 months/ 200 op. hours*
Pendant control, support wire for damage	X		X	
Electrical equipment, power supply for damage	X			X
Brake function			X	
Brake air gap		X		X
Function of limit switch and slip clutch (if available)	X		X	
Lubricate wire rope, grease rope drum	X	X		X
Wire rope for wear, wire breaks, deformations acc. to DIN 15020			X	
Load hook and connection for cracks and deformations		X		X
Screwed connections for security, welds for cracks		X		X
Inspect and lubricate gearbox				X

* Medium load spectrum according to table 1



Yale Electric Wire Rope Winch



SELBY ENGINEERING & LIFTING SAFETY LTD.

Lifting Equipment and Height Safety Specialists

www.liftingsafety.co.uk sales@liftingsafety.co.uk

Tel: +44 (0) 1977 684 600 Fax: +44 (0) 1977 685 300

Inspection Record

Date of inspection before initial operation _____

by: _____

Date of initial operation: _____

Regular Inspections

Date	Findings	Repair	Test	
			Date	by *

* competent person

Yale Electric Wire Rope Winch

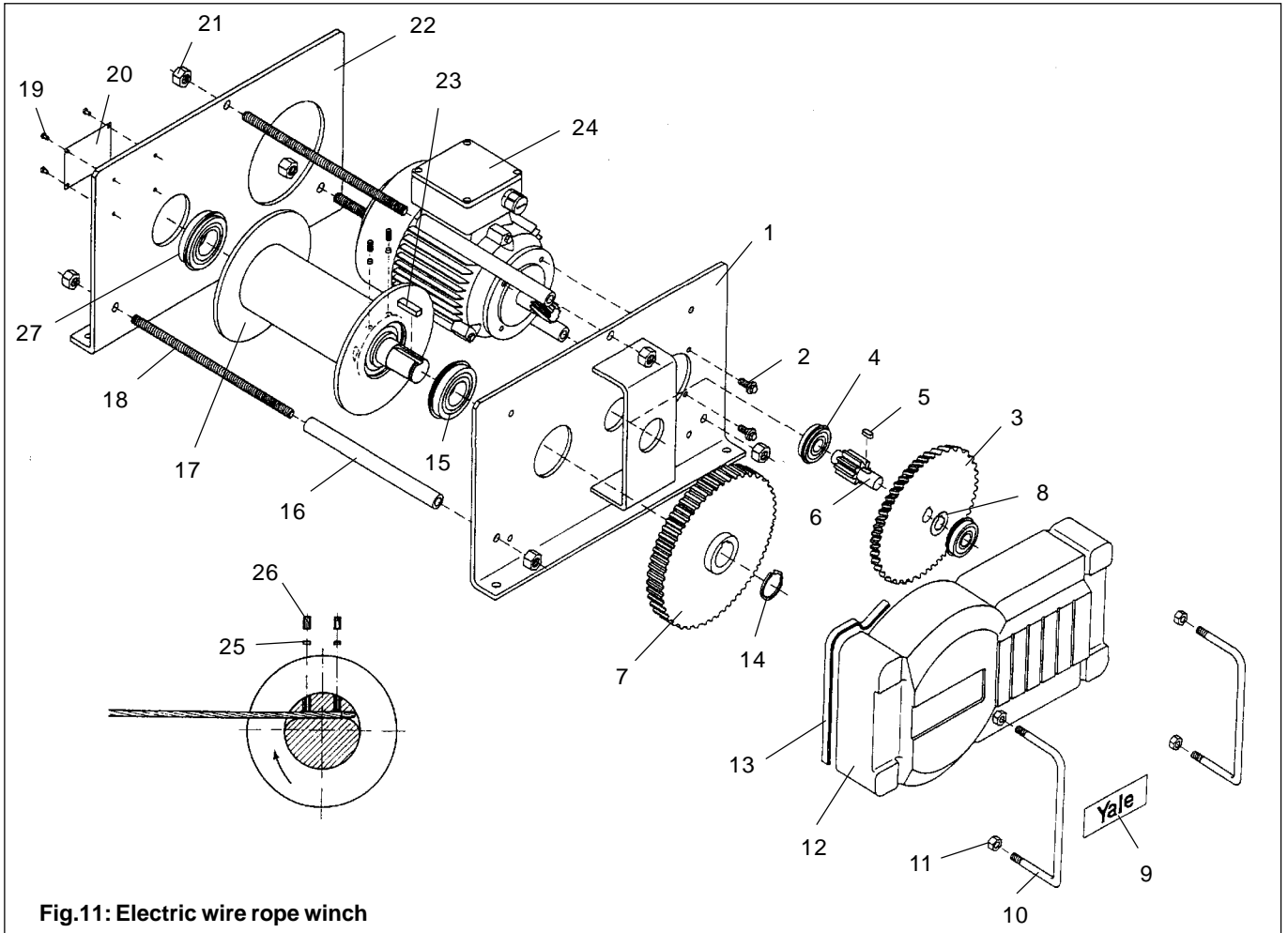
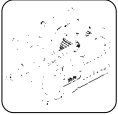

Fig.11: Electric wire rope winch

No.	Description	Qty.	Yale Part-No.				No.	Description	Qty.	Yale-Art. Nr.			
			for RPE 2-13, RPE 5-6	RPE 5-12	RPE 9-6	RPE 10-6				for RPE 2-13, RPE 5-6	RPE 5-12	RPE 9-6	RPE 10-6
1	Sideplate, drive side	1	0650008	0650106	0650066	0650066	15	Ball bearing	1	9151109	9151109	9151110	9151110
2	Hex. screw	4	9101664	9101664	9101665	9101665	16	Spacer tube	3	siehe S. 9	siehe S. 9	siehe S. 9	siehe S.9
3	Gear	1	0650002	0650105	0650088	siehe S. 9	17	Rope drum	1	siehe S. 9	siehe S. 9	siehe S. 9	siehe S.9
4	Ball bearing	2	9151108	9151108	9151111	9151111	18	Threaded bolt	3	siehe S. 9	siehe S. 9	siehe S. 9	siehe S.9
5	Key	1	9131075	9131078	9131037	9131037	19	Blind rivet	4	9126072	9126072	9126072	9126072
6	Pinion	1	0650003	0650103	0650064	0650064	20	Identification plate	1	0650024	0650024	0650024	0650024
7	Gear	1	0650004	0650104	0650065	0650065	21	Hex. nut	6	9115123	9115123	9115115	9115115
8	Spacer washer	1	0650013	9121215	9121205	9121205	22	Sideplate	1	0650006	0650006	0650068	0650068
9	Nameplate	1	0650026	0650026	0650026	0650026	23	Key	1	9131047	9131047	9131077	9131077
10	Bracket	2	0650023	0650023	0650092	0650092	24	Brake motor 230/400 V -3-50	1	0650021	0650061	0650061	0650061
11	Hex. nut	4	9115098	9115098	9115098	9115098		Brake motor 230 V -1-50	1	-	-	-	-
12	Gear cover	1	0650022	0650022	0650093	0650093	25	Copper washer	2	0650020	0650020	0650087	0650087
13	U-profile rubber seal	2	9004500	9004500	9004500	9004500	26	Grub screw	2	9114066	9114066	9114075	9114075
14	Circlip	1	9129013	9129013	9129032	9129032	27	Ball bearing	1	9151109	9151109	9151112	9151112

For model RPE 2-13 the items no. 5 - 7 must be replaced by the parts depicted on the following page.



Yale Electric Wire Rope Winch

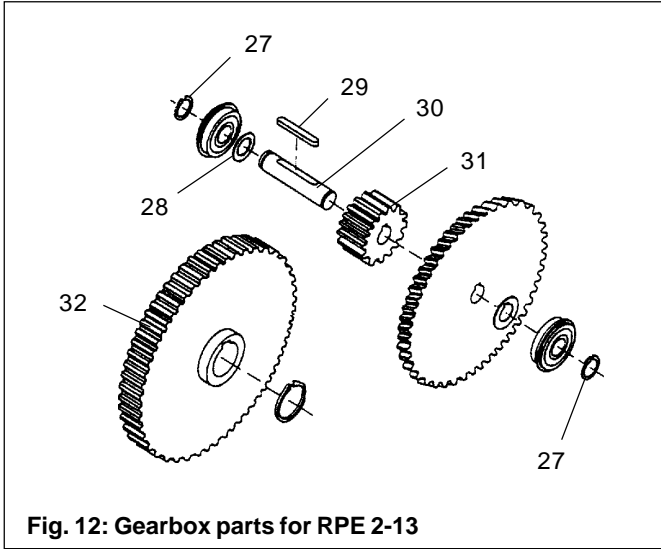

No.	Description	Qty.	Yale Part-No.
			only for RPE 2-13
27	Circlip	2	9129029
28	Shim	1	9121215
29	Key	1	9131076
30	Shaft	1	0650031
31	Pinion	1	0650029
32	Gear	1	0650030

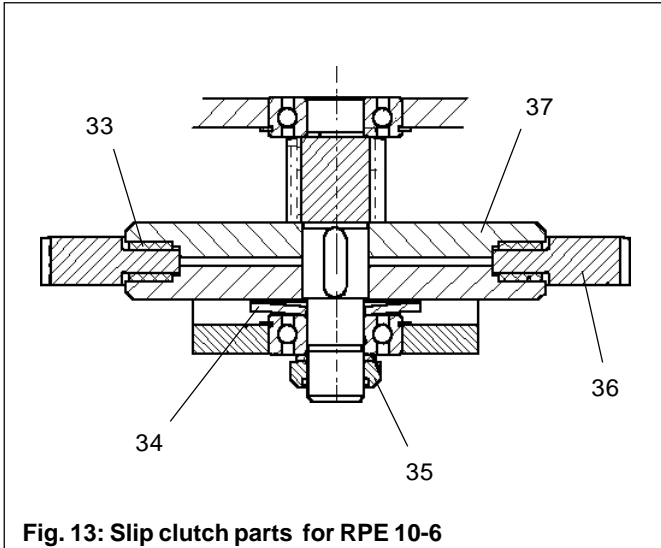

No.	Description	Qty.	Yale Part-No.
			only for RPE 10-6
33	Friction disc	2	0608909
34	Cup spring	1	9120050
35	Slotted nut	1	9118023
36	Gear	1	0650063
37	Brake disc	2	0650089

No.	Description		Yale Part-No.				
			RPE 2-13	RPE 5-6	RPE 5-12	RPE 9-6	RPE 10-6
17	Standard drum	RPE	0650005	0650005	0650035	0650070	0650070
18	Threaded rod	RPE	9114188	9114188	9114189	0650071	0650071
16	Spacer tube	RPE	0650010	0650010	0650028	-	-
17	Extended drum	RPE . . L	0650035	0650035	-	0650112	0650112
18	Threaded rod	RPE . . L	9114189	9114189	-	0650114	0650114
16	Spacer tube	RPE . . L	0650028	0650028	-	-	-
17	Standard drum with machined grooves	RPE . . R	0650101	0650036	0650037	0650118	0650118
18	Threaded rod	RPE . . R	9114188	9114188	9114189	0650071	0650071
16	Spacer tube	RPE . . R	0650010	0650010	0650028	-	-
17	Extended drum with machined grooves	RPE . . LR	0650090	0650037	-	0650119	0650119
18	Threaded rod	RPE . . LR	9114189	9114189	-	0650114	0650114
16	Spacer tube	RPE . . LR	0650028	0650028	-	-	-
17	Standard drum with separating disc	RPE . . T	0650038	0650038	0650039	0650120	0650120
18	Threaded rod	RPE . . T	9114188	9114188	9114189	0650071	0650071
16	Spacer tube	RPE . . T	0650010	0650010	0650028	-	-
17	Extended drum with separating disc	RPE . . LT	0650039	0650039	-	0650121	0650121
18	Threaded rod	RPE . . LT	9114189	9114189	-	0650114	0650114
16	Spacer tube	RPE . . LT	0650028	0650028	-	-	-

Table 2: Rope drums

Yale Electric Wire Rope Winch

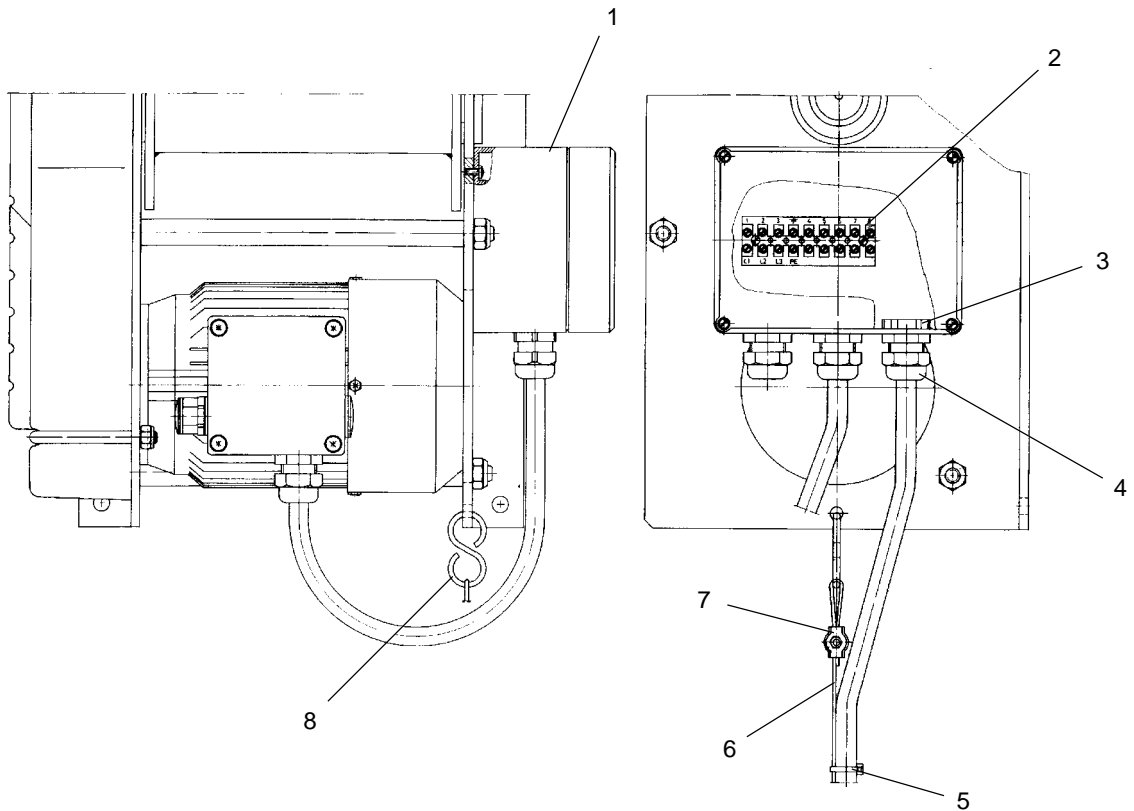
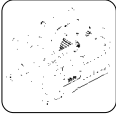

Fig. 14: Direct control

No.	Description	Qty.	Yale Part No.	Description	Qty.	Yale Part No.	
			For all winches			For all winches	
1	Housing	1	0650057	5	Cable strap (for 2 m)	5	9181113
2	Terminal strip	1	0650054	6	Strain relief cable (for 2 m)	1	9093001
3	Counternut	3	9184086	7	Rope clamp	2	0605355
4	Fitting	3	9184082	8	S-hook	2	0717029



Yale Electric Wire Rope Winch

SELBY ENGINEERING & LIFTING SAFETY LTD.
Lifting Equipment and Height Safety Specialists
www.liftingsafety.co.uk sales@liftingsafety.co.uk
 Tel: +44 (0) 1977 684 600 Fax: +44 (0) 1977 685 300

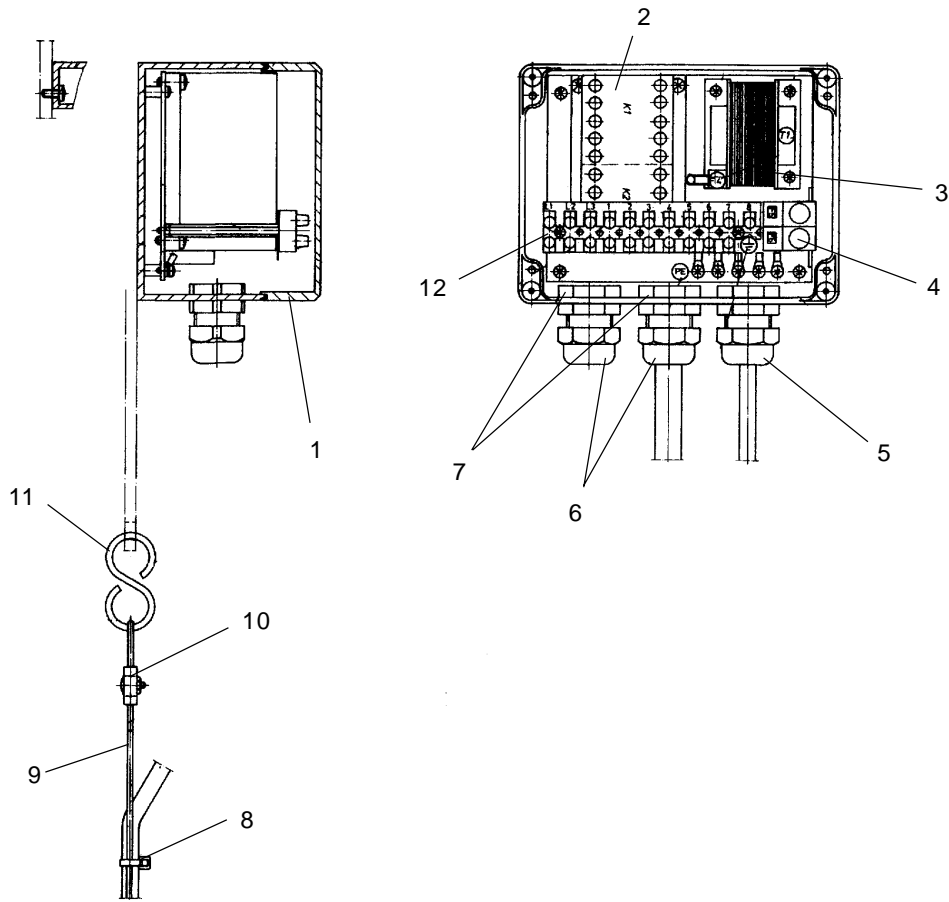

Fig. 15: Contactor control

No.	Description	Qty.	Yale Part-No.		Description	Qty.	Yale Part-No.	
				For all winches				For all winches
1	Housing	1	0650057		7	Counternut	3	9184086
2	Reversing contactor	1	0719662		8	Cable strap (for 2 m)	5	9181113
3	Transformer	1	0719737		9	Strain relief cable (for 2 m)	1	9093001
4	Fine fuse	2	9190128		10	Rope clamp	2	0605355
5	Fitting	1	9184089		11	S-hook	2	0717029
6	Fitting	2	9184082		12	Terminal strip	1	0719664

Yale Electric Wire Rope Winch

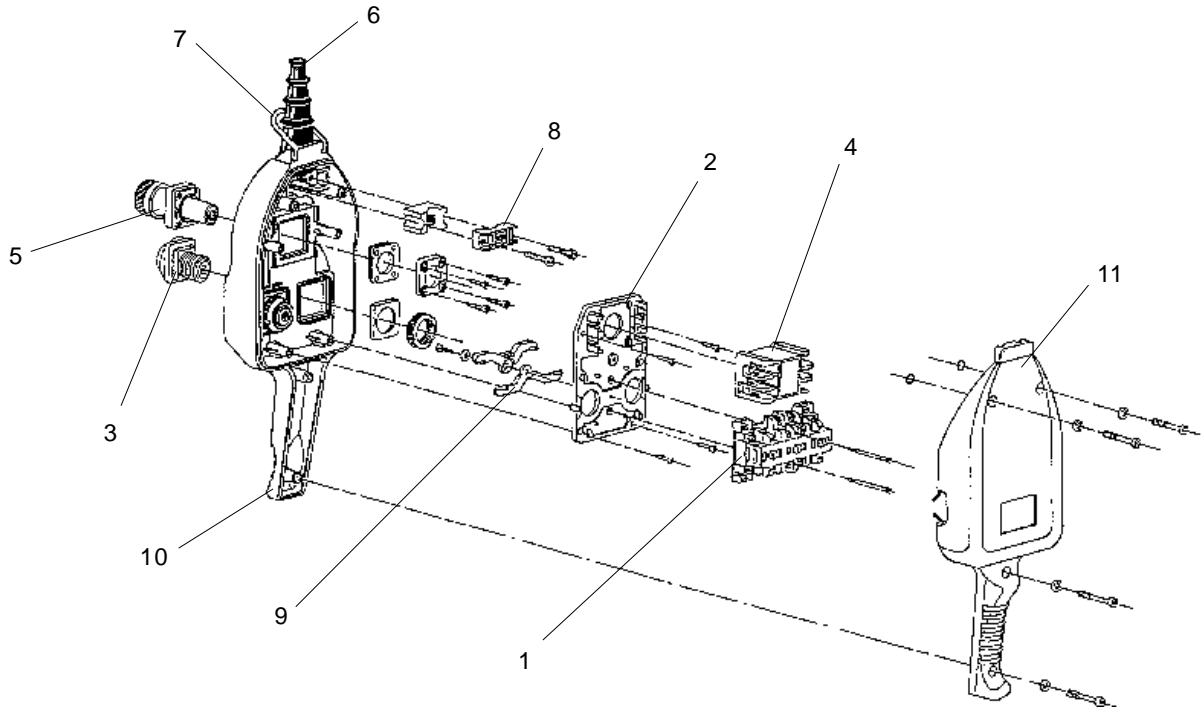
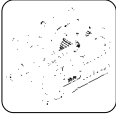

Fig. 16: Control switch for direct control

No.	Description	Qty.	Yale Part-No.	No.	Description	Qty.	Yale Part No.
			for all winches				for all winches
-	Control switch assy.	1	0609454	6	Anti-kink boot	1	0609970
1	Contact element	1	0609686	7	Clip for strain relief cable	1	0609971
2	Mounting for contact element	1	0609965	8	Clamp	1	0609972
3	Button AB (down)	1	0609966	9	Lever	1	0609973
	Button AUF (up)	1	0609968	10	Front housing half	1	0609974
4	Contact element f. emergency OFF	1	0609978	11	Rear housing half	1	0609975
5	Button for emergency OFF	1	0609977				



Yale Electric Wire Rope Winch

SELBY ENGINEERING & LIFTING SAFETY LTD.
Lifting Equipment and Height Safety Specialists
 www.liftingsafety.co.uk sales@liftingsafety.co.uk
 Tel: +44 (0) 1977 684 600 Fax: +44 (0) 1977 685 300

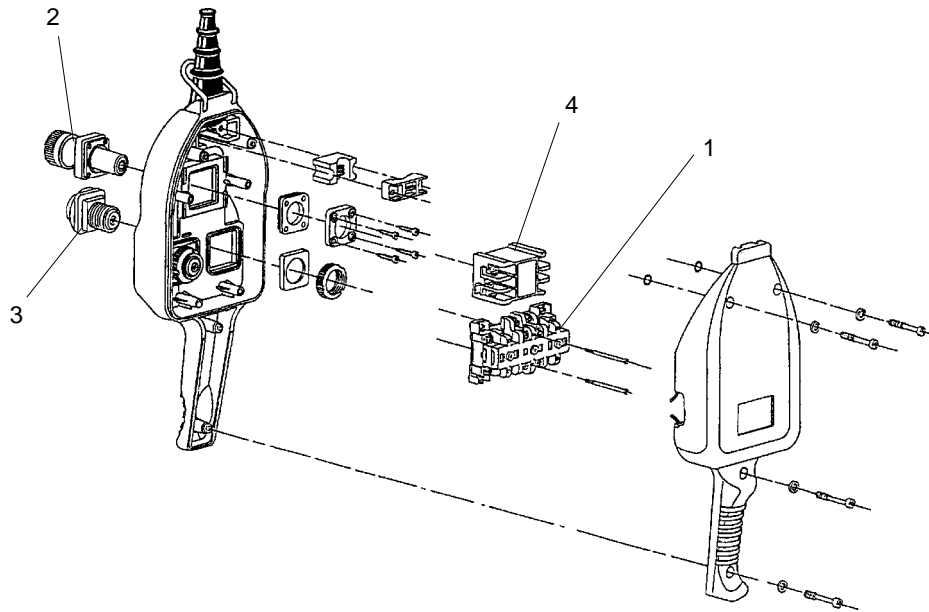

Fig. 17: Control switch for 42 V control

No.	Description	Qty.	Yale Part-No.
			for all winches
-	Control switch assy.		0609566
1	Contact element	1	0609980
2	Button for emergency OFF	1	0609984
3	Button AB (down)	1	0609985
	Button AUF (up)	1	0609987
4	Contact element f. emergency OFF	1	0609982

Yale Electric Wire Rope Winch

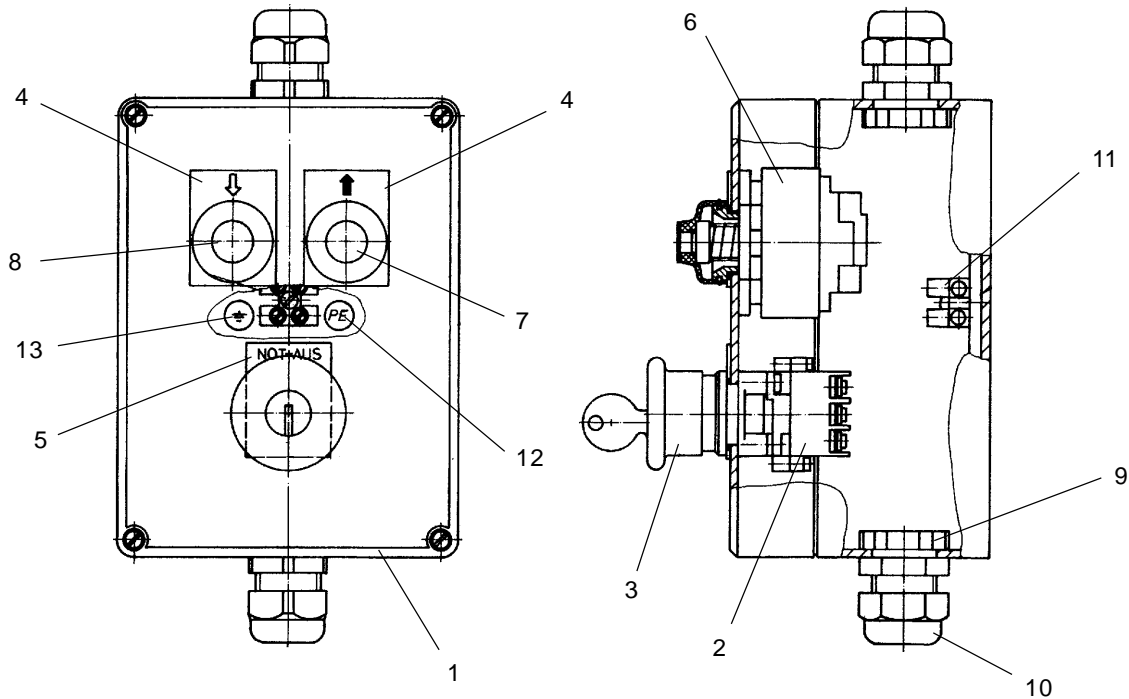

Fig. 18: Wall switch

No.	Description	Qty.	Yale Part-No.	Description	Qty.	Yale Part-No.	
			for all winches			for all winches	
-	Wall switch assy.	1	6600001	7	Button with protective boot (white)	1	0650042
1	Housing	1	0650049	8	Button with protective boot (black)	1	0650043
2	Contact element f. emergency OFF	1	0650044	9	Counternut	2	9184086
3	Button for emergency OFF	1	0650045	10	Fitting	2	9184082
4	Symbol label UP (white)	1	0650046	11	Terminal strip	1	0650050
	Symbol label DOWN (black)	1	0650047	12	Sticker (PE)	1	0650051
5	Label emergency OFF	1	0650048	13	Sticker (ground)	1	0650052
6	Switch block	2	0650041				

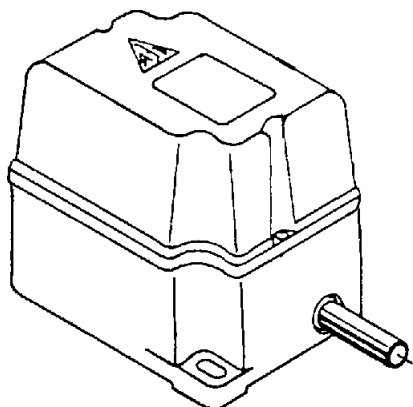

Fig. 19: Limit switch

No.	Description	Qty.	Yale Part-No.
			for all winches
-	Limit switch (1 : 15)	1	6600014
-	Limit switch (1 : 25)	1	6600015
-	Limit switch (1 : 50)	1	6600016
-	Limit switch (1 : 75)	1	6600017
-	Limit switch (1 : 100)	1	6600018
-	Limit switch (1 : 150)	1	6600019

MANUFACTURER'S DECLARATION in accordance with Machinery Directive 98/37/EEC (Appendix II B)

We,

YALE INDUSTRIAL PRODUCTS GMBH
D- 42549 Velbert, Am Lindenkamp 31

hereby declare that the construction of the below mentioned machine / component has been designed for the assembly to a machine / for the combination with other machines / components to a machine and that its operation is disallowed until it has been ascertained that the machine to which the electric wire rope winch is to be installed complies with the requirements of the Machinery Directive, edition 93/44/EEC.

Machine description:	Electric wire rope winch RPE Mod. RPE 2-13, Mod. RPE 5-6, Mod. RPE 5-12 Mod. RPE 9-6, Mod. RPE 10-6 Capacity 250 - 1000 kg
Machine type:	Electric wire rope winch
Serial number:	from manufacturing year 05/96 (Serial numbers for the individual capacities/models are registered in the production book with the remark CE-sign)
Relevant EC Directives:	EC Machinery Directive 98/37/EEC.
Transposed harmonised standards, in particular:	EN 292, part 1 (safety of machines) EN 292, part 2 (safety of machines) EN 394 (safety of machines)
Transposed (either complete or in extracts) national standards and technical specifications, in particular:	FEM 9.682 (Hubmotoren) FEM 9.755 (Betriebsdauer) FEM 9.511 (Triebwerkseinstufung) 9. GSGV VBG 8 (Winden, Hub- und Zuggeräte) VBG 9.a (Lastaufnahmemittel) DIN 15020 (Grundsätze Seiltriebe) DIN 3051, Teil 4 (Drahtseile aus Stahldrähten) DIN 2078 (Seildraht) DIN 3093 (Pressung) DIN 15400 (Lasthaken für Hebezeuge) DIN 15404 (Lasthaken für Hebezeuge) ZH 1/25 (Prüfung von Hubgeräten)
Quality assurance:	DIN/ISO 9001 bzw. DIN/EN 29001, module H according to EC Directive 90/683 EEC
Date / Manufacturer's authorized signature:	06.05.1996 
Identification of signee:	Manager Quality Assurance

**Quality engineered
and performance tested -
recognisably **Yale****

 **SELBY ENGINEERING & LIFTING SAFETY LTD.**
Lifting Equipment and Height Safety Specialists
www.liftingsafety.co.uk sales@liftingsafety.co.uk
Tel: +44 (0) 1977 684 600 Fax: +44 (0) 1977 685 300