

Product number: IN-2007

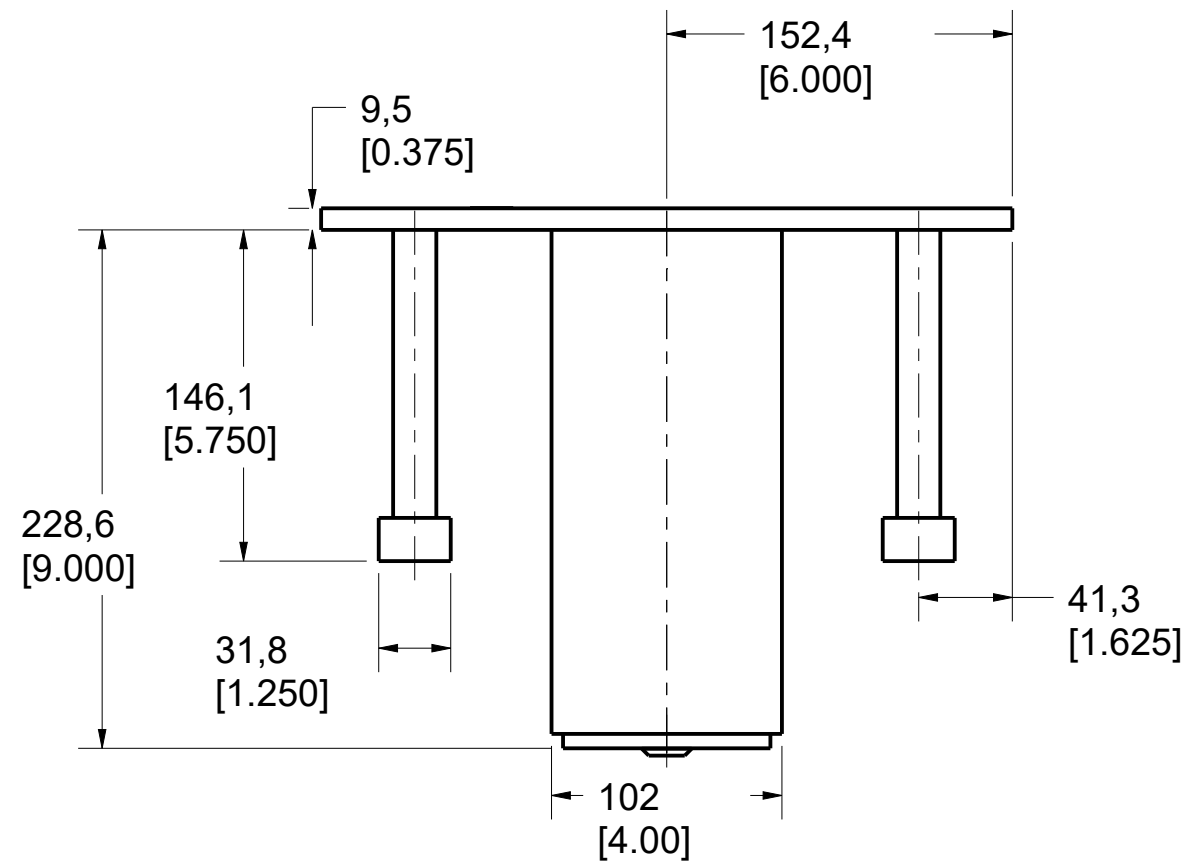

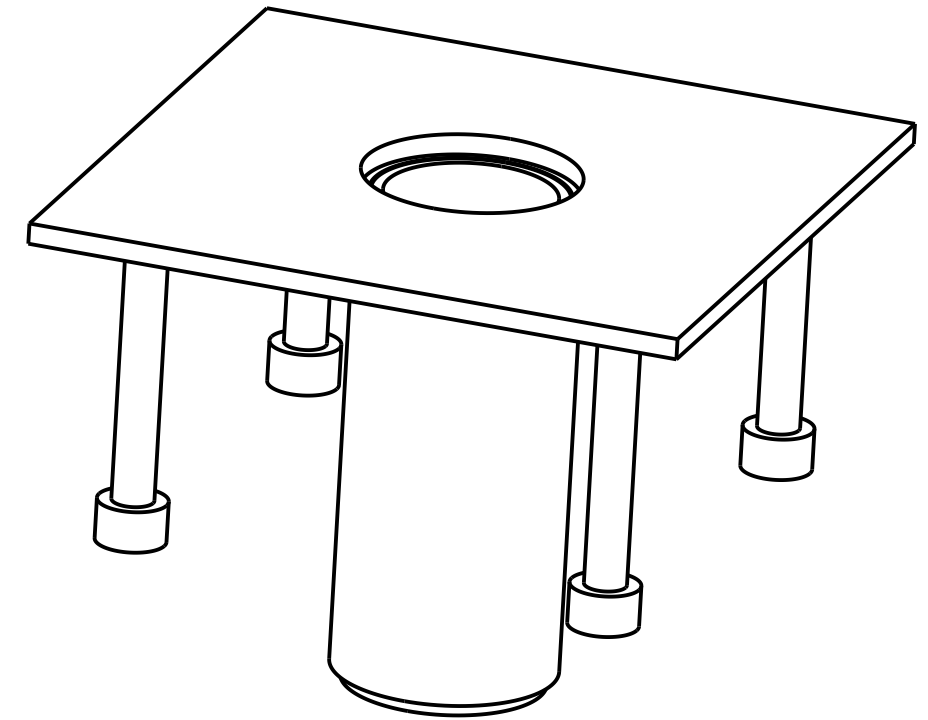
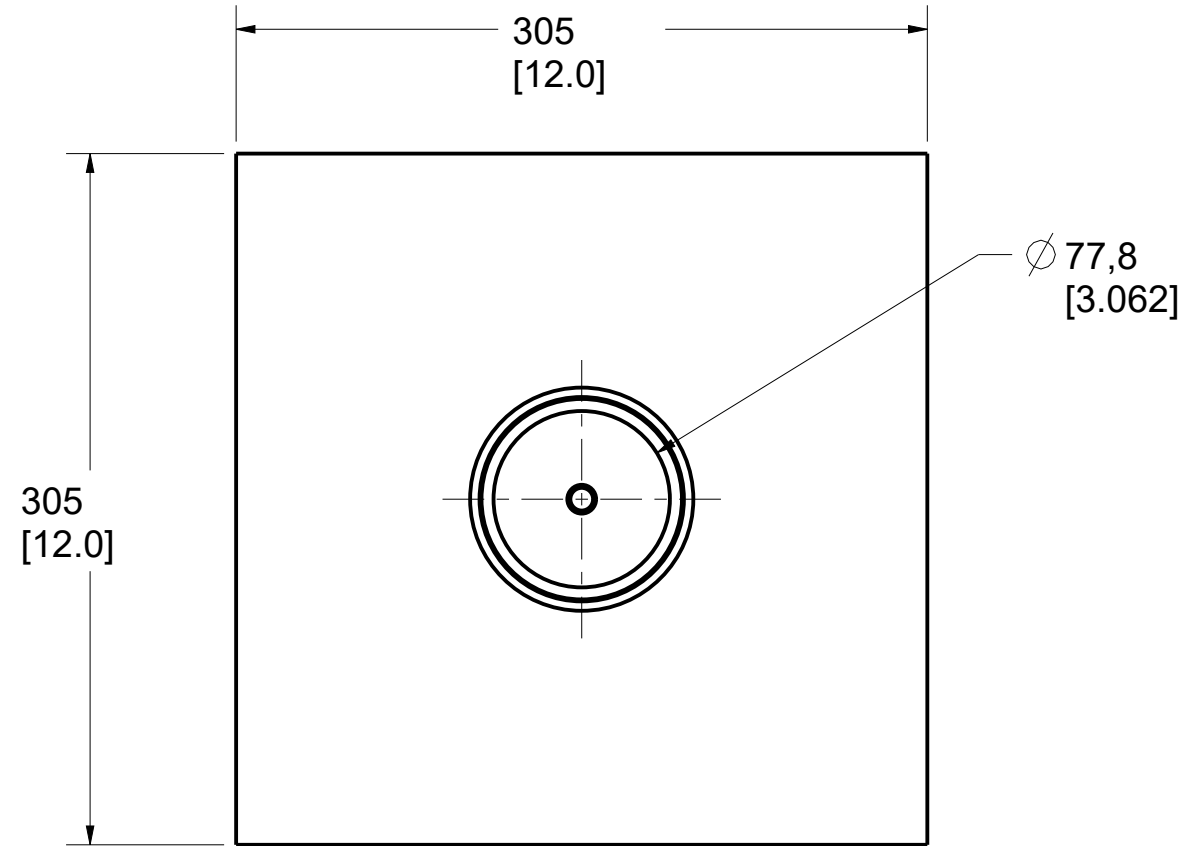

PAT.NO.:				
PRODUITS DE SERVICE PUBLICS INNOVA INC. INNOVA PUBLIC UTILITY PRODUCTS INC.				
© 9105-0732 QUEBEC INC. and under exclusive license to INNOVA PUBLIC UTILITY PRODUCTS INC., (hereafter « INNOVA »). All rights reserved. Protected under the Copyright Act of Canada and international treaties and agreements regarding copyrights. Violators are subject to prosecution and other legal recourses for infringement. Any reproduction, adaptation or other use or disclosure whatsoever, in totality or in part, and in any form or by any means whatsoever, strictly forbidden and requires the prior written approval of INNOVA. All data is the exclusive property of 9105-0732 QUEBEC INC. and under exclusive license to INNOVA and cannot be used nor disclosed in any way either without the prior written approval of INNOVA.				
WEIGHT:	TITLE:			
27 Lb	76mm (3") Fresh concrete Floor Adapter			
12 Kg	(SS 304)			
COLOR:	Material:	SHEET(S):	PROJET:	Rev.
	SS 304	1 / 4	IN-2007	01

IN-2007 Base Installation Requirements(CSA,OSHA,ANSI)

Concrete must be made of 0,2% gross area rebar reinforced 13.8 MPa (2000psi) or better. Minimum thickness of 165mm (6-1/2").

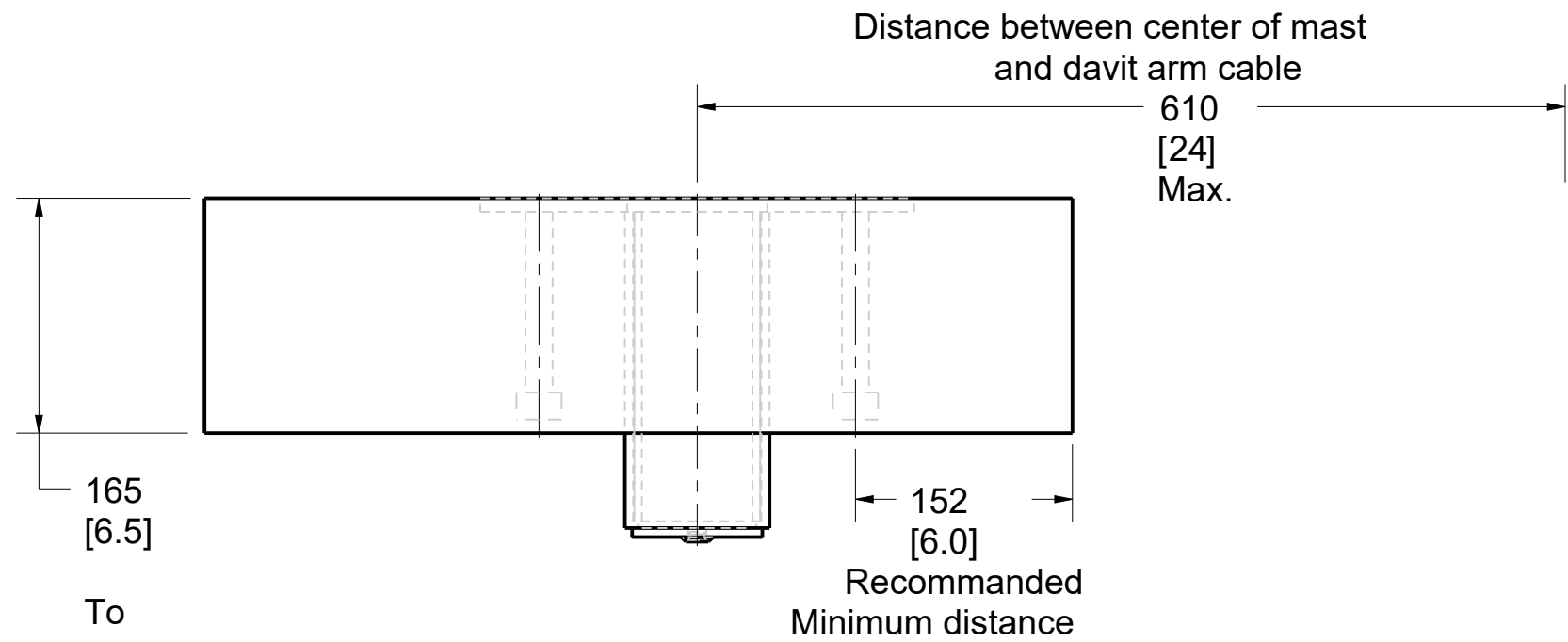
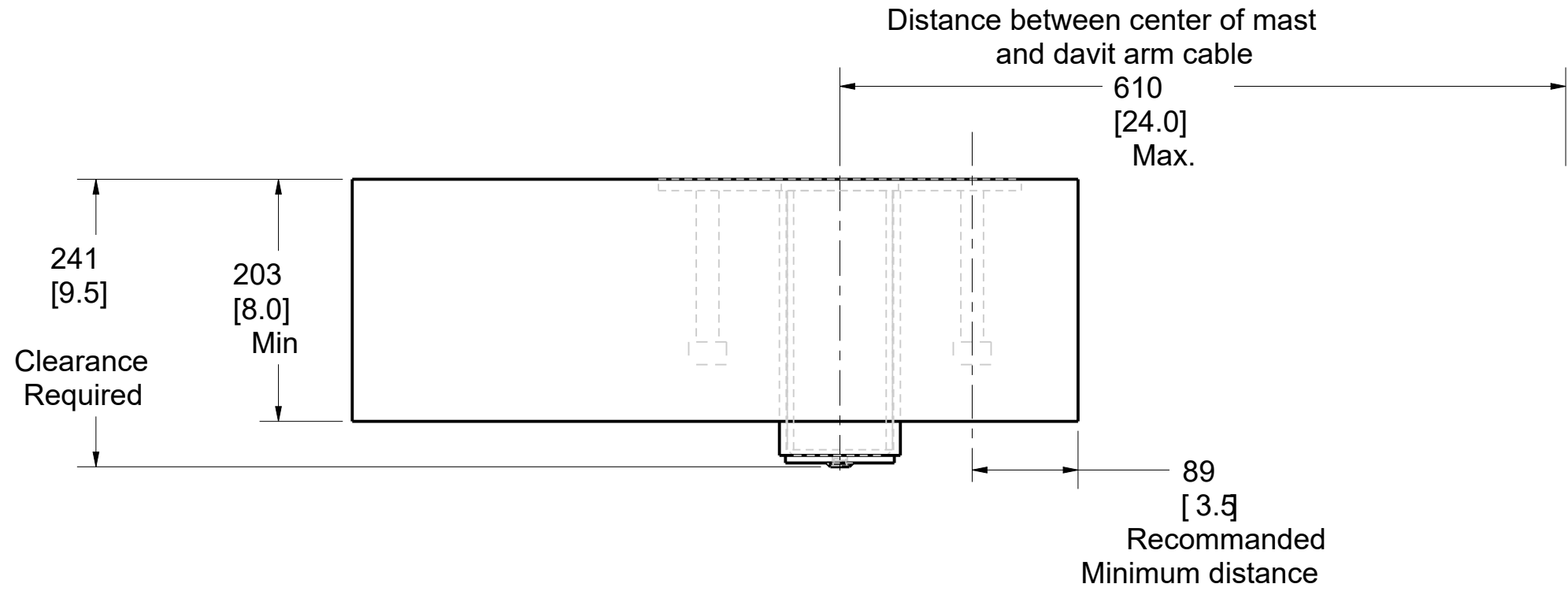
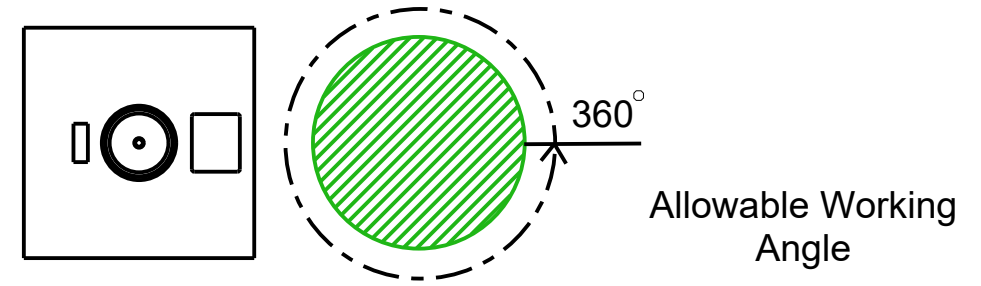
Moment capacity: 13,558 N-m (120,000 lbf-in).
Vertical load: 22,241 N (5,000 lbf).
Note: It is the responsibility of the field Engineer to assure installation compliance.



PAT.NO.:				
PRODUITS DE SERVICE PUBLICS INNOVA INC. INNOVA PUBLIC UTILITY PRODUCTS INC.				
<small>© 9105-0732 QUEBEC INC. and under exclusive license to INNOVA PUBLIC UTILITY PRODUCTS INC., (hereafter « INNOVA »). All rights reserved. Protected under the Copyright Act of Canada and international treaties and agreements regarding copyrights. Violators are subject to prosecution and other legal recourses for infringement. Any reproduction, adaptation or other use or disclosure whatsoever, in totality or in part, and in any form or by any means whatsoever, strictly forbidden and requires the prior written approval of INNOVA. All data is the exclusive property of 9105-0732 QUEBEC INC. and under exclusive license to INNOVA and cannot be used nor disclosed in any way either without the prior written approval of INNOVA.</small>				
WEIGHT:	TITLE:			
27 Lb	76mm (3") Fresh concrete Floor Adapter			
12 Kg	(SS 304)			
COLOR:	Material:	SHEET(S):	PROJET:	Rev.
	SS 304	2 / 4	IN-2007	01

SPECIFICATIONS

This equipment is considered as part of a personal fall arrest system (PFAS) with a maximum working capacity of 164 Kg (360 lb).

It is only to be used in conjunction with a personal fall arrest system that limits the maximum arrest force (MAF).

Maximum Working Moment: 976 N-m (8,640 lbf-in)
Maximum Moment: 13,558 N-m (120,000 lbf-in)

STANDARDS

Meets the following standards:
 OSHA Personal fall arrest system - 1910.66 App C
 ANSI Safety requirements for personal fall arrest system, subsystems and components Z359.1 (R1999) / 2007
 CAN/CSA Fall arresters, vertical lifelines, and rails Z259.2.1-98
 CE EN 795:2012 Type A
 CEN/TS 16415: 2013 (2 Users)

MATERIAL AND CONSTRUCTION

Plate, gussets and sleeve : 304 Stainless Steel
 Sleeve bearing : PVC Pipe.
 Welding Certification : CSA W59 & W47.1, AWS D1.6

RESTRICTIONS

IMPORTANT :

Adaptors are designed to function only with Innova Public Utility Products inc. equipment.

****The positioning pins must always be in place when manoeuvring personnel. Otherwise, serious injuries may occur.**

In the occurrence of a fall or the safety of the equipment is in doubt, equipment must be immediately removed from service and inspected by qualified personnel before reuse.

**** This equipment must always be installed in a level position.**

**** Always use a protection adapter cap when adapter is used outside and/or when possible freezing can occur.**

Product number: IN-2007

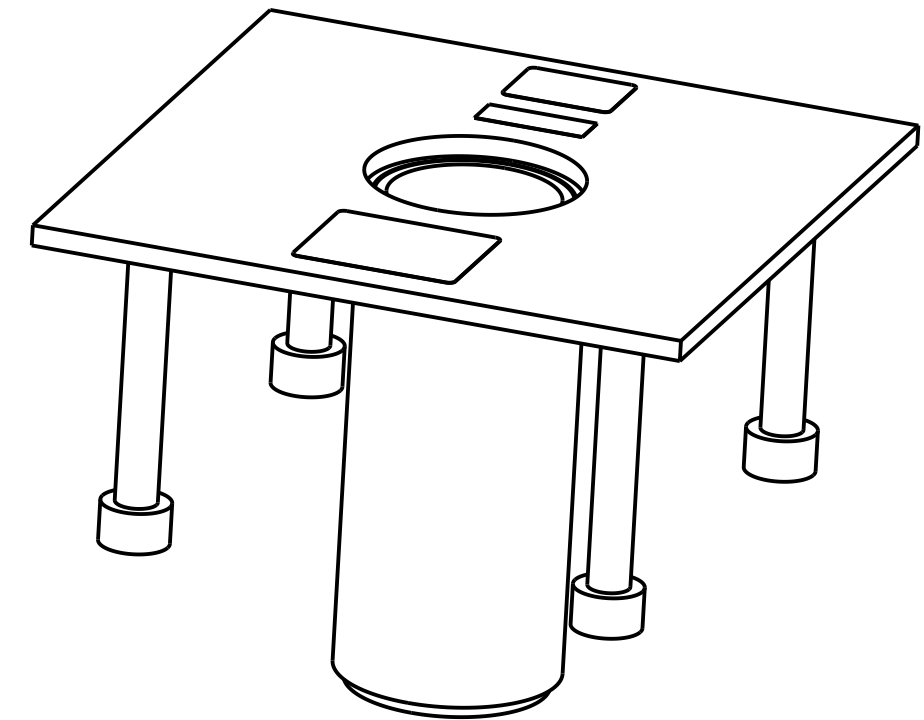

PAT.NO.:				
PRODUITS DE SERVICE PUBLICS INNOVA INC. INNOVA PUBLIC UTILITY PRODUCTS INC.				
© 9105-0732 QUEBEC INC. and under exclusive license to INNOVA PUBLIC UTILITY PRODUCTS INC., (hereafter « INNOVA »). All rights reserved. Protected under the Copyright Act of Canada and international treaties and agreements regarding copyrights. Violators are subject to prosecution and other legal recourses for infringement. Any reproduction, adaptation or other use or disclosure whatsoever, in totality or in part, and in any form or by any means whatsoever, strictly forbidden and requires the prior written approval of INNOVA. All data is the exclusive property of 9105-0732 QUEBEC INC. and under exclusive license to INNOVA and cannot be used nor disclosed in any way either without the prior written approval of INNOVA.				
WEIGHT:	TITLE:			
27 Lb	76mm (3") Fresh concrete Floor Adapter (SS 304)			
12 Kg				
COLOR:	Material:	SHEET(S):	PROJET:	Rev.
	SS 304	3 / 4	IN-2007	01

8

7

6

5

4

3

2

1

Product number: IN-2007

H

G

F

E

D

C

B

A

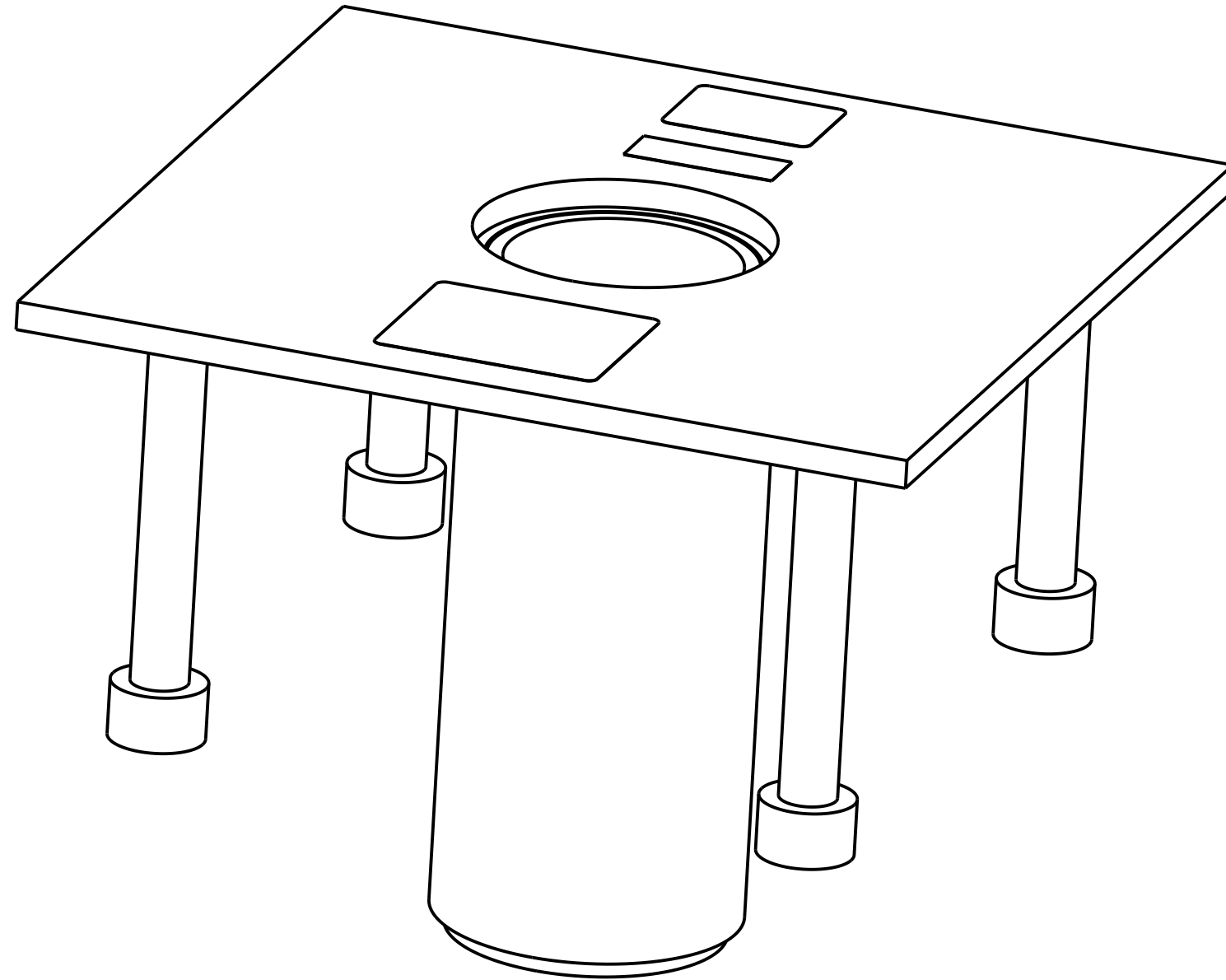

H

G

F

E

D

C

B

A

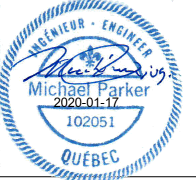
PAT.NO.:				
PRODUITS DE SERVICE PUBLICS INNOVA INC. INNOVA PUBLIC UTILITY PRODUCTS INC.				
<small>© 9105-0732 QUEBEC INC. and under exclusive license to INNOVA PUBLIC UTILITY PRODUCTS INC., (hereafter « INNOVA »). All rights reserved. Protected under the Copyright Act of Canada and international treaties and agreements regarding copyrights. Violators are subject to prosecution and other legal recourses for infringement. Any reproduction, adaptation or other use or disclosure whatsoever, in totality or in part, and in any form or by any means whatsoever, strictly forbidden and requires the prior written approval of INNOVA. All data is the exclusive property of 9105-0732 QUEBEC INC. and under exclusive license to INNOVA and cannot be used nor disclosed in any way either without the prior written approval of INNOVA.</small>				
WEIGHT:	TITLE:			
27 Lb	76mm (3") Fresh concrete Floor Adapter			
12 Kg	(SS 304)			
COLOR:	Material:	SHEET(S):	PROJET:	Rev.
	SS 304	4 / 4	IN-2007	01

8

7

6

5

4

3

2

1