



# Duff-Norton®

## Mechanical Actuators

### Translating Machine Screw Actuators

2-Ton through 75 Ton Capacity

Installation, Operation  
& Maintenance Instructions

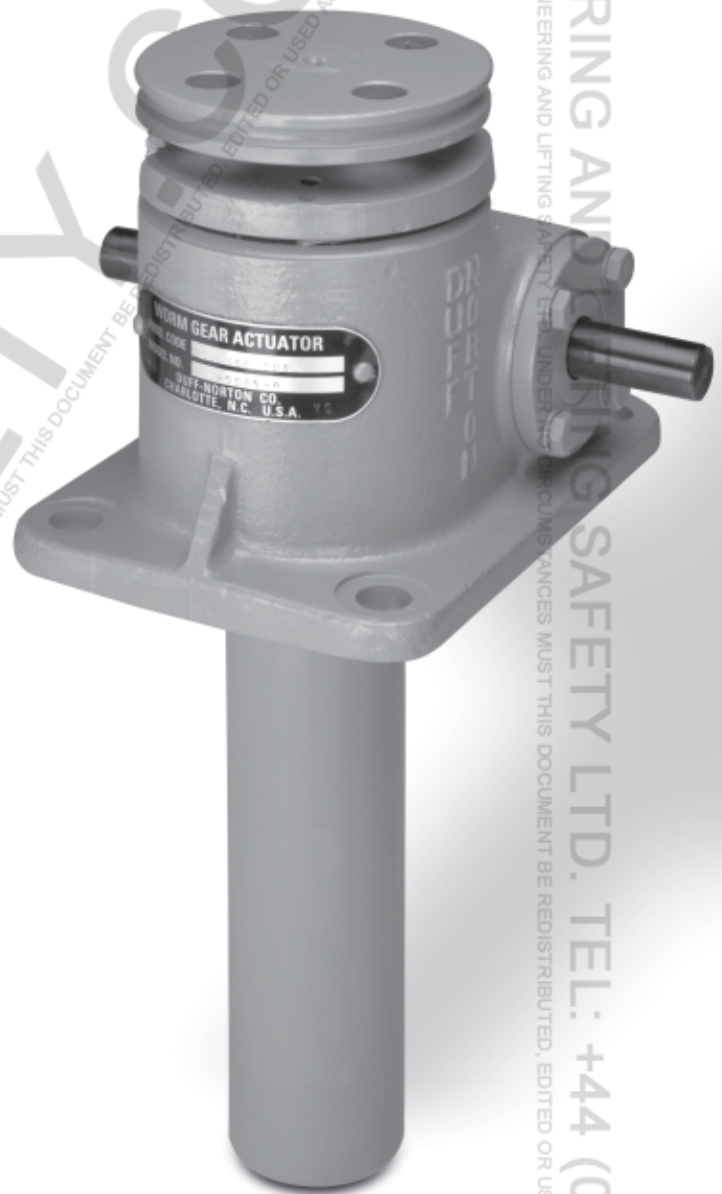

**Publication Part No. SK-2389**

**⚠ CAUTION**

This manual contains important information for the correct installation, operation and maintenance of the equipment described herein. All persons involved in such installation, operation, and maintenance should be thoroughly familiar with the contents. To safeguard against the possibility of personal injury or property damage, follow the recommendations and instructions of this manual and keep it for further reference.

**⚠ WARNING**

The equipment shown in this manual is intended for industrial use only and should not be used to lift, support, or otherwise transport people.

# Contents

Section I	General Information .....	2
1-1.	General .....	2
1-2.	Applications .....	2
1-3.	Specifications .....	2
1-4.	Important Precautions .....	3
1-5.	Warranty and Warranty Repair .....	4
Section II	Maintenance .....	4
2-1.	Lubrication .....	4
2-2.	Rebuild Procedure .....	4
2-3.	Required Tools .....	4
2-4.	Disassembly .....	4
2-5.	Cleaning .....	5
2-6.	Inspection .....	5
2-7.	Assembly .....	5
2-8.	Anti-Backlash Nut Function .....	6
2-9.	Anti-Backlash Nut Adjustment .....	6
Section III	Illustrated Parts List .....	6
3-1.	General .....	6
3-2.	Parts List .....	6
Figure 3-1.	Exploded Illustration .....	7

## Section I

### General Information

#### 1-1. General

This manual contains maintenance instructions for Duff Norton translating machine screw actuators of two ton to 75 ton capacity. It describes and details procedures for installation, disassembly, cleaning, inspection, and assembly of these actuators.

These actuators are intended for a clean, non-corrosive environment with ambient temperatures ranging from -20 to 200 ° F. If your environment is dirty and/or contains abrasive particles it is important to protect the screw with a boot. If your atmosphere is corrosive it is important to specify a non-corrosive material or finish. Duff-Norton can provide stainless steel, nickel plated or epoxy coated actuators. If your duty is high or your use severe, more frequent lubrication should be employed. Duff-Norton publishes a Mechanical Actuator Design Guide, Catalog No. 2003, which you may find helpful in the selection and application of mechanical actuators. If you need additional help, please contact Duff-Norton at (800) 477-5002.

#### 1-2. Applications

**Industrial Use Only** The actuators described and illustrated in this manual are intended for industrial use only and should not be used to lift, support or otherwise transport people unless you have a written statement from Duff-Norton which authorizes the specific actuator unit, as used in your application, as suitable for moving people.

#### 1-3. Specifications

**Table 1. 1800 (2000) and 9000 (10000) Series**

Standard Actuator Model No.	Upright	1802 & 9002	9005	9010	9015	9020	9025	9035	1850 & 9050	9075
	Inverted	1801 & 9001	9004	9009	9014	9019	9024	9034	1849 & 9049	9074
Special Actuator Model No. <td>Upright</td> <td>2002 &amp; 10002</td> <td>10005</td> <td>10010</td> <td>10015</td> <td>10020</td> <td>10025</td> <td>10035</td> <td>2050 &amp; 10050</td> <td>10075</td>	Upright	2002 & 10002	10005	10010	10015	10020	10025	10035	2050 & 10050	10075
	Inverted	2001 & 10001	10004	10009	10014	10019	10024	10034	2049 & 10049	10074
Rated Load (tons)		2	5	10	15	20	25	35	50	75
Diameter of Lifting Screw (inches)		1 .250 Pitch Acme	1 1/2 .375 Pitch Acme	2 .500 Pitch Acme	2 1/4 .500 Pitch Acme	2 1/2 .500 Pitch Acme	3 .666 Pitch Acme	3 3/4 .666 Pitch Acme	4 1/2 .666 Pitch Square	5 .666 Pitch Square
Closed Height** (inches)		5 1/4	7	7 1/4	8	9 1/4	11	12	13	16 1/2
Base Size (inches)		3 1/2 x 7 4 1/8 x 6 1/4	6 x 8	7 1/2 x 8 3/4	7 3/4 x 9 1/4	8 1/4 x 11	10 1/4 x 13 3/4	10 1/4 x 15 1/2	9 3/4 x 19 3/4 10 1/2 x 21 3/4	14 x 23
Worm Gear Ratios	Std Ratio	6:1	6:1	8:1	8:1	8:1	10 2/3:1	10 2/3:1	10 2/3:1	10 2/3:1
	Optional	24:1	24:1	24:1	24:1	24:1	32:1	32:1	32:1	32:1
Turns of Worm For 1" Raise	Std Ratio	24	16	16	16	16	16	16	16	16
	Optional	96	64	48	48	48	48	48	48	48
Maximum H.P. Per Actuator	Std Ratio	2	4	5	5	5	8	8	15	15
	Optional	1/2	3/4	1 1/2	1 1/2	1 1/2	2 1/2	2 1/2	6	6
Torque at Full Load* (in-lbs)	Std Ratio	120	450	750	1,430	2,050	2,700	4,000	7,500	12,000
	Optional	50	185	400	820	1,170	1,200	2,400	4,200	6,600
Actuator Efficiency Rating (%)	Std Ratio	23.2	22.1	23.7	20.2	18.8	18.7	15.8	13.8	12.4
	Optional	13.3	12.1	15.1	12.9	12.0	10.5	8.9	8.3	7.5
Weight with Base Raise of 6" (lbs)		17	35	52	66	93	160	240	410	650
Weight for Each Additional 1" of Raise (lbs)		.33	.85	1.4	1.5	2.6	2.5	3.7	5.5	6.5

\* For loads from 25% to 100% of actuator load rating. Torque requirements are approximately proportional to the load.

\*\* Closed heights are for standard upright top plate models and may vary with different screw end, inverted models, or when bellows boot is used.

**Table 2. 4800 and 9400 Series**

Standard Actuator Model No.	Upright	4802 & 9402	9405	9410	9415	9420	9425	9435	4850 & 9450	9475
	Inverted	4801 & 9401	9404	9409	9414	9419	9424	9434	4849 & 9449	9474
Special Actuator Model No.	Upright	5802 & 10402	10405	10410	10415	10420	10425	10435	5850 & 10450	10475
	Inverted	5801 & 10401	10404	10409	10414	10419	10424	10434	5849 & 10449	10474
Rated Load (tons)		2	5	10	15	20	25	35	50	75
Torque at Full Load* (in-lbs)	Std Ratio	135	500	1045	1573	2255	1320	4400	4620	13200
	Optional	55	205	905	1290	1320	1320	2640	4620	7260
Actuator Efficiency Rating (%)	Std Ratio	19.6	19.9	19.8	18.0	17.6	13.4	13.7	12.4	11.3
	Optional	11.9	10.9	12.6	11.0	10.8	8.3	7.7	7.3	6.8
Closed Height (in)**		5 1/4	7	7 1/4	8	9 1/2	12	13	14	18 1/2
Weight with Base Raise of 6" (lbs)		18	37	55	70	101	197	250	440	700

Note: Additional specifications are same as for Series 1800 and 9000. See Table 1.

\* For loads from 25% to 100% of actuator load rating. Torque requirements are approximately proportional to the load.

\*\* Closed heights are for standard upright top plate models and may vary with different screw end, inverted models, or when bellows boot is used.

**Table 3. Decimal Ratios**

Standard Actuator Model No.	Upright	1802 & 9002	9005	9010	9015	9020	9025
	Inverted	1801 & 9001	9004	9009	9014	9019	9024
Special Actuator Model No.	Upright	2002 & 10002	10005	10010	10015	10020	10025
	Inverted	2001 & 10001	10004	10009	10014	10019	10024
Rated Load (tons)		2	5	10	15	20	25
Lifting Screw (inches)		1" Dia. .250 Pitch Acme	1 1/2" Dia. .250 Pitch Acme	2" Dia. .250 Pitch Acme	2 1/4" Dia. .250 Pitch Acme	2 1/2" Dia. .250 Pitch Acme	3" Dia. .320 Pitch Square
Worm Gear Ratios		25:1	25:1	25:1	25:1	25:1	32:1
Turns of Worm For 1" Raise		100	100	100	100	100	100
Torque at Full Load (in-lbs)		48	175	370	640	925	1500
Actuator Efficiency Rating (%)		13.2	9.1	8.6	7.5	6.9	5.3
Maximum H.P. Per Actuator		1/2	3/4	1 1/2	1 1/2	1 1/2	2 1/2

Note: All other data for these models same as shown in Table 1.

**1-4 Important Precautions**

In order to ensure that Duff-Norton actuators provide good service over a period of years the following precautions should be taken:

1. Select an actuator that has a load rating greater than the maximum load that may be imposed on it.
2. The structure on which the actuator is mounted should have ample strength to carry the maximum load, and should be rigid enough to prevent undue deflection or distortion of the actuator supporting members.
3. It is essential that the actuator be carefully aligned during installation so that the lifting screws are perfectly plumb and the connecting shafts are exactly in line with the worm shafts. After the actuators, shafting, gear boxes, etc., are coupled together, it should be possible to turn the main drive shaft by hand. If there are no signs of binding or misalignment, that actuator system is then ready for normal operation.
4. Actuators should have a greater raise than is needed in the actual application. Should it be necessary to operate the actuator at the extreme limits of travel, it should be done cautiously.

**specified (catalog) closed height, or serious damage to internal mechanism may result. Refer to table of specifications (par. 1-3) for closed heights of respective units.**

5. The worm shaft speed for these actuators should not exceed 500 RPM for heavy loads, 1200 RPM for light loads of one-fourth (or less) of the actuators load rating.
6. The lifting screw should not be permitted to accumulate dust and grit on the threads. If possible, lifting screws should be returned to closed position when not in use.

**⚠ CAUTION**

**Where lifting screws are not protected from airborne dirt, dust, etc., bellows boots should be used. Inspect frequently at regular intervals to be certain that a lubricating film is present. Lifting screws should never be run dry.**

7. When using an 1800 (2000) or 9000 (10000) Series Actuator, a periodic check of backlash of the lifting screw thread is recommended to check wear of the worm gear internal threads. The normal backlash on a new unit of this type is approximately .010 inch. Backlash of 50% or more of the thread thickness indicates the need to replace the worm gear.

The 4800 and 9400 Series Anti-backlash Actua-

**⚠ CAUTION**

**Do not allow actuator travel to go beyond**

tors are designed to be adjusted for minimum backlash, approximately .002 inch. The worm gear and anti-backlash nut are manufactured to have a clearance between their surfaces of 1/2 the thread thickness. When adjustments have been made to the point where all this clearance is gone, 50% of the thread thickness is gone and replacement is necessary. (See paragraph 2-8 for a detailed explanation of how the anti-backlash nut functions.)

#### Note

For loads of from 25% to 100% of actuator capacity, torque requirements are approximately proportioned to the load.

8. The lubrication procedures for normal and severe service conditions, as described in Section II, paragraph 2-1, should be closely followed.

### 1-5. Warranty and Warranty Repair

Subject to the conditions stated herein, Duff-Norton will repair or replace, without charge, any parts proven to Duff-Norton's satisfaction to have

been defective in material or workmanship. Claims must be made within one year after date of shipment. Duff-Norton will not repair or replace any parts that become inoperative because of improper maintenance, eccentric loading, overloading, chemical or abrasive action, excessive wear, or other abuse.

Equipment and accessories not of Duff-Norton's manufacture are warranted only to the extent that they are warranted by the manufacturer, and only if the claimed defect arose during normal use, applications and service. Equipment which has been altered or modified by anyone without Duff-Norton's authorization is not warranted by Duff-Norton.

EXCEPT AS STATED HEREIN, DUFF-NORTON MAKES NO OTHER WARRANTIES, EXPRESS OR IMPLIED, INCLUDING WARRANTIES OF MERCHANTABILITY AND FITNESS FOR A PARTICULAR PURPOSE.

If you have any questions concerning warranty repair, please contact Duff-Norton. Authorization for return must be received from Duff-Norton before returning any equipment for inspection or warranty repair.

## Section II Maintenance

### 2-1. Lubrication

Unless otherwise specified, actuators are shipped packed with grease which should be sufficient for one month of normal operation. For normal operation, the actuator should be lubricated once a month using Extreme Pressure grease Shell Oil Co. Albida LC EP #2 (Shell Product Code 70311).

This grease has been thoroughly evaluated in Duff-Norton actuators and has demonstrated superior lubricating properties affecting both wear life and maximum duty cycle. **Duff-Norton is not aware of an equivalent grease.** If this grease is not available in your area please contact your local supplier for their recommendations. Greases containing molybdenum disulfide should never be used.

For severe service conditions, the actuators should be lubricated more frequently using the above grease (daily to weekly depending upon the conditions). If duty is heavy, an automatic lubrication system is strongly recommended.



#### CAUTION

**Where lifting screws are not protected from airborne, dirt, dust, etc., bellows boots should be used. Inspect frequently at regular intervals to be certain that a lubricating film is present. Lifting screws should never be run dry.**

### 2-2. Rebuild Procedure

Duff-Norton recommends the following procedures for assembly and disassembly of actuators.

1. Tag critical parts to facilitate reassembly.
2. Mark mating surfaces to ensure proper meshing.
3. Clean and lubricate all parts as required.
4. All seals must be replaced when rebuilding.
5. All screws, washers and other small common parts must be replaced if damaged in any way.
6. Replace damaged or frozen lubrication fittings with new ones.

### 2-3 Required Tools

A bearing puller or press, and common hand tools are necessary for proper assembly and disassembly.

### 2-4. Disassembly (Refer to Figure 3-1)

1. Remove lifting screw (5) from actuator.
2. Remove bottom pipe (4) from shell (3) (upright models) or shell cap (2) (inverted models) or base plate as applicable.
3. Loosen and remove set screws (1) in cap (2) and remove cap from shell (3).

#### Note

It may be necessary to break shell cap or base plate loose with a hammer.

4. Remove gear (6A) or worm gear and nut assembly (6B) from shell (3).

**Note**

To facilitate removal of the gear from the shell on models with 50- ton or higher load ratings, partially reassembly the lifting screw into the worm gear (or worm gear and nut assembly) and use a hoist or pulley block to lift on the screw.

5. Remove top load bearing (7) which may be attached to either shell cap (2) or worm gear (6A) or anti-backlash nut.

**Note**

Use only a soft face hammer to tap bearings loose.

6. Remove bottom load bearing (8) which may be attached to either the shell (3) base plate or worm gear (6A).
7. Remove four cap screws (9) from each of the two worm flanges (11) and remove flanges.

**Note**

Be careful not to lose flange shims (12).

8. Press oil seal (13) out of flange (11).
9. Remove worm (14) and worm bearings (15) from shell (3) by striking one end of worm with a soft face hammer.
10. Remove worm bearings (15) from worm (14) with bearing puller or press. (Note: This step will not be necessary if worm or worm bearings are not damaged).
11. If actuator is keyed, remove screw in shell cap and tap key out of keyway.

## 2-5. Cleaning

1. Use degreasing solvent to remove grease or oil from all parts.

**Note**

Remove grease from unit and do not reuse old grease.

**▲ WARNING**

**Provide adequate ventilation during the use of cleaning agents; avoid prolonged breathing of fumes and contact with skin. Read & follow manufacturer's instructions.**

2. Use clean hot water or a soap solution for general cleaning of painted surfaces.
3. Dry parts thoroughly after cleaning.

**Note**

Before installing new parts, remove any rust preventive, protection grease, etc.

## 2-6. Inspection (Refer to Figure 3-1)

Inspect actuator parts as follows:

1. Make a visual inspection of shell (3) for broken, cracked or distorted areas. Check threads of all bores for burrs or broken threads.
2. Check shell cap (2), base plate, bottom pipe (4), lifting screw (5), worm gear (6A) or worm gear and nut assembly (6B) for burrs or scratches on their working or mating surfaces.
3. Check fit between lifting screw thread and internal thread in worm gear. If fit is excessively loose, replace worm gear or lifting screw as required. Replace worm gear and nut assembly as a set [4800 (5800) and 9400 (10400) Series].
4. Check small common components (screws, etc.) and replace as required.
5. Check bearings (7), (8) and (15) for seizure, galling or play and replace as required.

## 2-7. Assembly (Refer to Figure 3-1)

1. Press worm bearings (15) onto worm shaft (14), making sure that bearings are seated properly against shoulder.

**Note**

When tapered roller bearings are used, the small end of the cone should point to the worm end.

2. Position worm shaft end (14) in shell (3).

**Note**

If tapered roller bearings are used, tap worm bearing cups into place in the shell.

3. Press oil seals (13) into worm flange (11).

**Note**

The sealing element should point inward.

4. Position worm flanges (11) with shims (12) and bolt in place.
5. Position bottom load bearing (8) or bearing cup in shell (3).
- 5a. On 5-ton, 35-ton and 75-ton models, press load bearing cones onto worm gear (6A) or worm gear and nut assembly (6B).
6. Install worm gear (6A) or worm gear and nut assembly (6B) in shell (3).

**Note**

Strike each end of worm shaft sharply with a soft face hammer to seat bearing properly. Recheck flange bolts for tightness. Worm should turn freely with minimum drag and end play. If too much end play is present, remove shims as required. If worm does not turn freely, add shims

as required.

7. Install top load bearing (7) or bearing cup on worm gear (6A) or worm gear and nut assembly (6B).
8. Fill housing fully with grease.
9. Install shell cap (2) and screw down until tight.

**Note**

Shell cap flange does not necessarily have to bear against top of shell, there will usually be a gap. This will put a slight drag on the worm. If worm is hard to turn, back off slightly on the shell cap.

10. Lock base plate in place with set screws.

**Note**

If new parts have been installed, it may be necessary to respot holes for these screws.

11. Screw bottom pipe (4) into shell (3) (upright models) or into shell cap (2) (inverted models).
12. Brush lifting screw (5) with a light film of grease and install in actuator. On inverted models, install guide bushing (16) and then install lifting screw (5).
13. If actuator is keyed, install key in shell cap (2) and bolt in place.
14. Operate unit to ensure proper functioning of all components prior to reinstallation.

**2-8. Anti-Backlash Nut Function**

As shown in Figure 2-1, the worm gear (2) and anti-backlash nut (3) are pinned together with guide pins. The threads in the anti-backlash nut work in opposition to the threads in the worm gear as they

engage the threads of the lifting screw (1). Adjustment of backlash is made by running down on the shell cap of the actuator. This forces the anti-backlash nut threads into closer contact, reducing clearance and thus reducing backlash.

**2-9. Anti-Backlash Nut Adjustment**

1. To minimize backlash remove the two set screws (4) and tighten down on shell cap until the desired backlash is obtained. Spot drill top of shell through set screw holes, then replace set screws and tighten to prevent shell cap backing off.
2. To avoid binding and excessive wear, do not adjust lifting screw backlash to less than 0.002 inch.
3. The clearance (A) designed into the worm gear and anti-backlash nut set is one-half the thread thickness. When adjustments have been made to use all this clearance replace the worm gear and anti-backlash nut as a set.

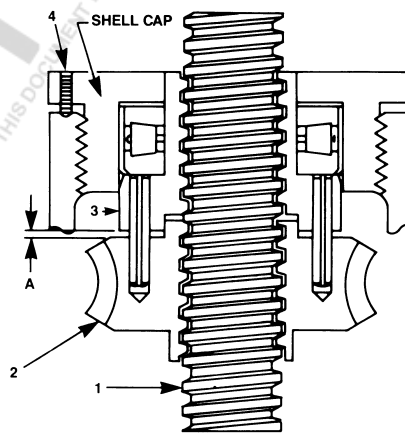

Figure 2-1. Anti-Backlash Nut Adjustment

**Section III  
Illustrated Parts List**

**3-1. General**

This section contains an exploded illustration of the 1800, 9000, 4800 and 9400 Series translating machine screw actuators. The number adjacent to each part on the illustration is the index number. Keyed to this index

number on the parts list is the part name.

When ordering parts be sure to include:

1. The nameplate model of your unit.
2. Index number and name of part.

**3-2. Parts List For 1800 (2000), 9000 (10000), 4800 (5800) and 9400 (10400) Series Translating Machine Screw Actuators.**

Index No.	Part Name	Qty. Req.
1	Screw, Set	1
2	Cap, Shell	1
3	Shell, Actuator	1
4	Pipe, Bottom	1
5	Screw Assembly, Lifting	1
6A	Worm Gear	1
6B	Worm Gear and Anti-backlash Nut Assembly (Mfg'd and sold in sets only)	1
7	Bearing, Top Load	1
8	Bearing, Bottom Load	1

Index No.	Part Name	Qty. Req.
9	Screw, Cap	12
10	Washer, Lock	12
11	Flange, Worm	2
12	Shim, Flange	2
13	Seal, Oil	2
14	Worm	1
15	Bearing, Worm	2
16	Bushing, Guide (inverted model o	1
18	Nameplate	1

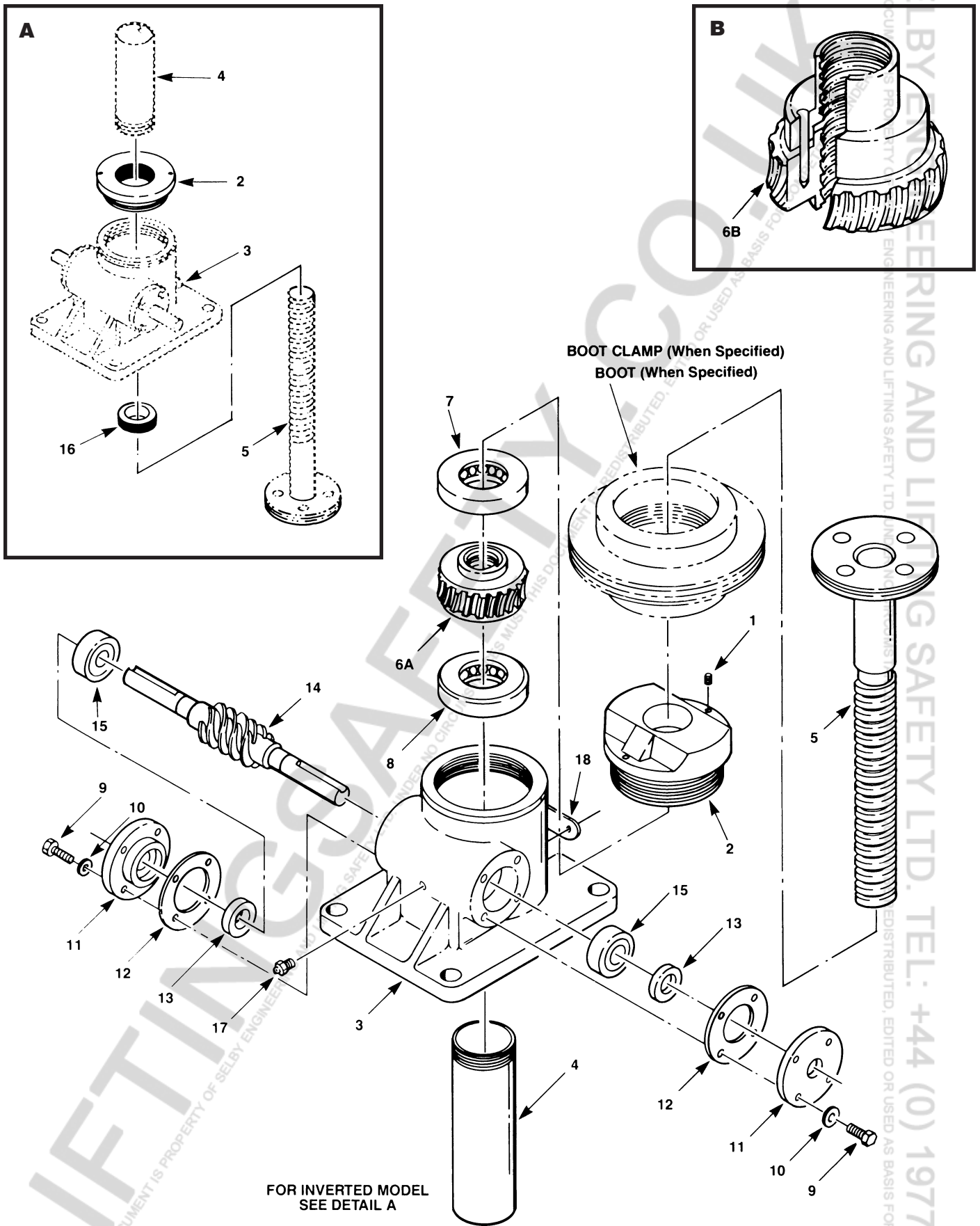
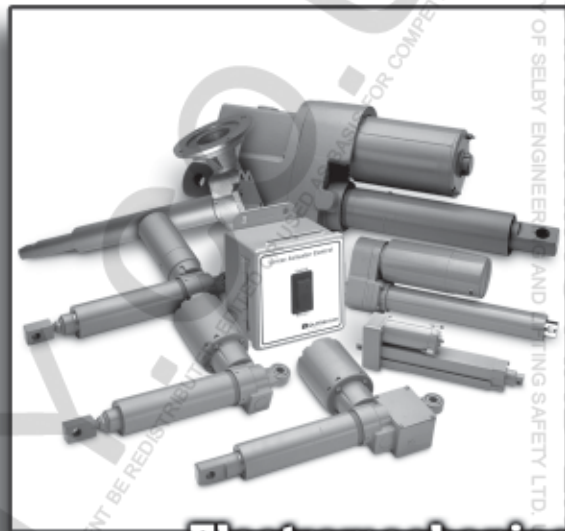

Figure 3-1. Exploded Illustration 1800 (2000), 9000 (10000), 4800 (5800) and 9400 (10400) Series Translating Machine Screw Actuators

# **Duff-Norton**<sup>®</sup>



**Mechanical Actuators**



**Electromechanical Actuators**

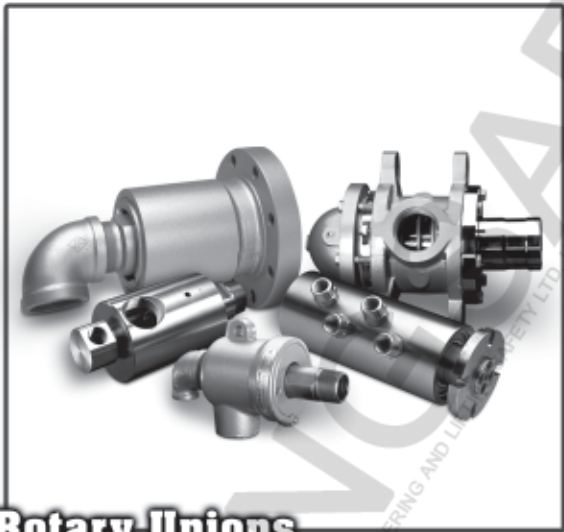

**Rotary Unions**



**Jacks**

## **Duff-Norton**<sup>®</sup>

P.O. Box 7010  
Charlotte, NC 28241-7010

General Office (704) 588-0510  
Customer Service (800) 477-5002  
Customer Service (704) 588-4610  
FAX (704) 588-1994

Email: [duffnorton@cmworks.com](mailto:duffnorton@cmworks.com)

[www.duffnorton.com](http://www.duffnorton.com)

