

Installation, Operating and Maintenance Instructions

Rotating Machine Screw Actuators

**2-Ton Capacity
and Larger**

Publication Part No. SK-2389-R

 **Caution**

This manual contains important information for the correct installation, operation and maintenance of the equipment described herein. All persons involved in such installation, operation, and maintenance should be thoroughly familiar with the contents. To safeguard against the possibility of personal injury or property damage, follow the recommendations and instructions of this manual and keep it for further reference.

 **Warning**

The equipment shown in this manual is intended for industrial use only and should not be used to lift, support, or otherwise transport people.

Contents

Section I	General Information	2
1-1.	General	2
1-2.	Applications	2
1-3.	Specifications	2
Table 1.	1800 and 9000 Series Rotating Machine Screw Actuators	2
Table 2.	Decimal Ratios	2
1-4.	Dimensions	3
Table 3.	Upright Models	3
Table 4.	Inverted Models	3
1-5.	Important Precautions	4
1-6.	Warranty and Warranty Repair	4
Section II	Maintenance	5
2-1.	Lubrication	5
2-2.	Rebuild Procedure	5
2-3.	Required Tools	5
2-4.	Disassembly (Refer to Figure 3-1)	5
2-5.	Cleaning	6
2-6.	Inspection (Refer to Figure 3-1)	6
2-7.	Assembly (Refer to Figure 3-1)	6
Figure 2-1.	Expansion Plug Replacement	7
Section III	Illustrated Parts List	10
3-1.	General	10
Figure 3-1.	Exploded Illustration 1800 and 9000 Series Rotating Machine Screw Actuators	11

Section I General Information

1-1. General

This manual contains maintenance instructions for Duff Norton 2 through 150-ton rotating machine screw actuators. It describes and details procedures for installation, disassembly, cleaning, inspection, and assembly of these actuators.

1-2. Applications

The actuators described and illustrated in this manual are intended for industrial use only and should not be used to lift, support or otherwise transport people unless you have a written statement from Duff-Norton which authorizes the specific actuator unit, as used in your application, as suitable for moving people.

1-3. Specifications

Table 1. 1800 and 9000 Series Rotating Machine Screw Actuators

Actuator No. Standard	Upright	UM1803 & UM9003	UM9006	UM9011	UM9016	AUM9021	UM9026	UM9036	UM1851 & UM9051	UM9076	UM9097	UM18151
	Inverted	DM1803 & DM9003	DM9006	DM9011	DM9016	ADM9021	DM9026	DM9036	DM1851 & DM9051	DM9076	DM9097	DM18151
Actuator No. Special	Upright	UM2003 & UM10003	UM10006	UM10011	UM10016	UM10021	UM10026	UM10036	UM2051 & UM10051	UM10076	UM10097	UM20151
	Inverted	DM2003 & DM10003	DM10006	DM10011	DM10016	DM10021	DM10026	DM10036	DM2051 & DM10051	DM10076	DM10097	DM20151
Rated Load (tons)		2	5	10	15	20	25	35	50	75	100	150
Diameter of Lifting Screw (Inches)		1	1 1/2	2	2 1/4	2 1/2	3	3 3/4	4 1/2	5	6	7
		.250 Pitch Acme	.375 Pitch Acme	.500 Pitch Acme	.500 Pitch Acme	.500 Pitch Acme	.666 Pitch Acme	.666 Pitch Acme	.666 Pitch Square	.666 Pitch Square	.750 Pitch Square	1.000 Square
Base Size (Inches)		3 1/2 x 7 1/8 x 6 1/4	6 x 8	7 1/2 x 8 3/4**	7 3/4 x 9 1/4	8 1/4 x 11	10 1/4 x 13 3/4	10 1/4 x 15 1/2	9 3/4 x 19 3/4***	14 x 23	20 3/4 x 24 1/2	20 3/4 x 24 1/2
Worm Gear Ratios	Std Ratio	6:1	6:1	8:1	8:1	8:1	10 2/3:1	10 2/3:1	10 2/3:1	10 2/3:1	12:1	12:1
	Optional	24:1	24:1	24:1	24:1	24:1	32:1	32:1	32:1	32:1	36:1	36:1
Turns of Worm For 1" Raise	Std Ratio	24	16	16	16	16	16	16	16	16	16	12
	Optional	96	64	48	48	48	48	48	48	48	48	36
Maximum H.P. Per Actuator	Std Ratio	2	4	5	5	5	8	8	15	15	25	25
	Optional	1/2	3/4	1 1/2	1 1/2	1 1/2	2 1/2	2 1/2	6	6	11	11
Torque at Full Load* (lb-ins)	Std Ratio	120	450	750	1,430	2,050	2700	4000	7,500	12000	16000	28100
	Optional	50	185	400	820	1,170	1200	2400	4,200	6600	8600	15500
Actuator Efficiency Rating (%)	Std Ratio	23.2	22.1	23.7	20.2	18.8	18.7	15.8	13.8	12.4	13.0	14.1
	Optional	13.3	12.1	15.1	12.9	20.2	10.5	8.9	8.3	7.5	8.	8.6
Weight with Base Raise of 6" (lbs)		17	35	52	66	93	160	240	410	650	1200	1350
Weight for Each Additional 1" of Raise (lbs)		.33	.85	1.4	1.5	2.6	2.5	4.1	5.5	6.5	9.0	12.6

* For loads of from 25% to 100% of Actuator load rating. Torque requirements are approximately proportional to the load.

** 9003 base is 4 1/8 x 6 1/4.

*** 9051 base is 10 1/4 x 21 3/4

These actuators are intended for a clean, non-corrosive environment with ambient temperatures ranging from -20 to 200 ° F. If your environment is dirty and/or contains abrasive particles it is important to protect the screw with a boot. If your atmosphere is corrosive it is important to specify a non-corrosive material or finish. Duff-Norton can provide

stainless steel, nickel plated or epoxy coated actuators. If your duty is high or your use severe, more frequent lubrication should be employed. Duff-Norton publishes a Mechanical Actuator Design Guide, Catalog No. 2003, which you may find helpful in the selection and application of mechanical actuators. If you need additional help, please contact Duff-Norton at (800) 477-5002.

Table 2. Decimal Ratios

Actuator No. Standard	Upright	1802 & 9002	9005	9010	9015	9020	9025
	Inverted	1801 & 9001	9004	9009	9014	9019	9024
Actuator No. Special	Upright						
	Inverted						
Rated Load (tons)		2	5	10	15	20	25
Lifting Screw (in.)		1" Dia. .250 Pitch Acme	1 1/2" Dia. .250 Pitch Acme	2" Dia. .250 Pitch Acme	2 1/4" Dia. .250 Pitch Acme	2 1/2" Dia. .250 Pitch Acme	3" Dia. .320 Pitch Square
Worm Gear Ratio		25:1	25:1	25:1	25:1	25:1	32:1
Torque at Full Load* (lb-ins)		100	100	100	100	100	100
Torque at Full Load* (lb-ins)	Std Ratio	48	175	370	640	925	1500
	Optional						
Actuator Efficiency Rating (%)	Std Ratio	13.2	9.1	8.6	7.5	6.9	5.3
	Optional						
Maximum H.P. per Actuator		1/2	3/4	1 1/2	1 1/2	1 1/2	2 1/2

Note: All other data for these models same as shown in Table 1.

1-4. Dimensions

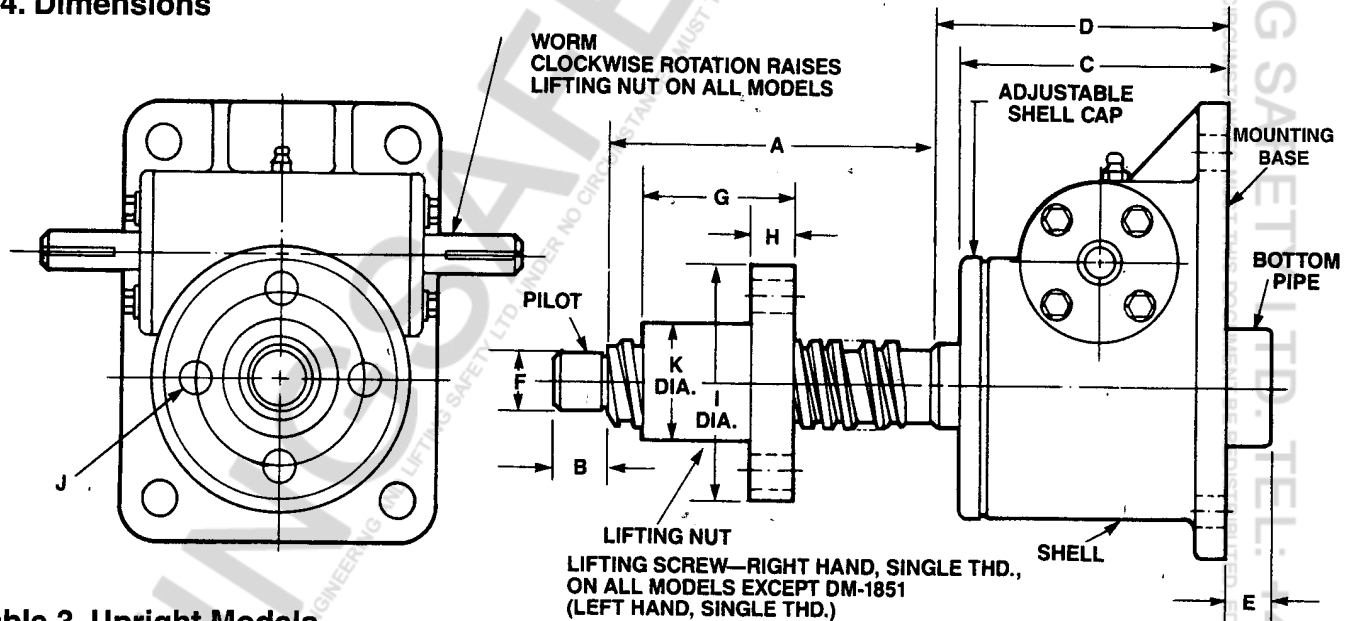

Table 3. Upright Models

Model Number	Rating (Tons)	A (in.)	B (in.)	C (in.)	D (in.)	E (in.)	F (in.)	G (in.)	H (in.)	I (in.)	J (in.)	K (in.)
UM-1803	2	Raise + 2 3/8	3/4	4 1/16	C	0	0.625	1 1/2	1 1/2	3 1/4	4 Holes - 13/32 Dia. On 2 3/8 Dia. B.C.	1 1/2
UM-9003	2	Raise + 2 3/8	3/4	4 1/16	C	0	0.625	1 1/2	1 1/2	3 1/4	4 Holes - 13/32 Dia. On 2 3/8 Dia. B.C.	1 1/2
UM-9006	5	Raise + 3	1	5 1/4	C	0	1.000	2 1/2	3/4	4	4 Holes - 9/16 Dia. On 3 Dia. B.C.	2
UM-9011	10	Raise + 4	2	5 5/8	C	1	1.249	3	1	6	4 Holes - 13/16 Dia. On 4 1/2 Dia. B.C.	3
UM-9016	15	Raise + 4	2	6 5/16	C	1	1.500	3	1	6 1/2	4 Holes - 13/16 Dia. On 5 Dia. B.C.	3 1/2
UM-9021	20	Raise + 5	2 1/2	7 1/8	C	1 3/4	1.750	3	1	7 1/2	4 Holes - 15/16 Dia. On 5 1/2 Dia. B.C.	3 3/4
UM-9026	25	Raise + 7	3	8 7/8	12	2	2.500	5 1/2	1 1/4	8 1/2	4 Holes - 1 1/16 Dia. On 6 1/2 Dia. B.C.	4 1/2
UM-9036	35	Raise + 6	3 1/2	8 7/8	C	2	3.000	5 1/2	1 1/2	9	4 Holes - 1 1/16 Dia. On 7 Dia. B.C.	5
UM-1851	50	Raise + 7	4	10 7/8	12	2 1/2	3.500	6	2	10	6 Holes - 1 1/16 Dia. On 8 Dia. B.C.	6
UM-9076	75	Raise + 8 1/2	4 1/2	13 9/16	14 5/8	2 1/2	4.000	7 1/2	2	12 1/2	6 Holes - 1 1/8 Dia. On 10 Dia. B.C.	7
UM-9097	100	Raise + 8	5	17	19	5	5.000	7	2	14	6 Holes - 1 1/8 Dia. On 11 Dia. B.C.	8
UM-18151	150	Raise + 9 3/4	5 1/2	17	19	3 1/2	5.500	8 3/4	2 1/2	15 1/2	6 Holes - 1 1/2 Dia. On 12 1/2 Dia. B.C.	9

Note: All dimensions are in inches and subject to change without notice.

1-4. Dimensions (cont.)

WORM
CLOCKWISE ROTATION RAISES
LIFTING NUT ON ALL MODELS

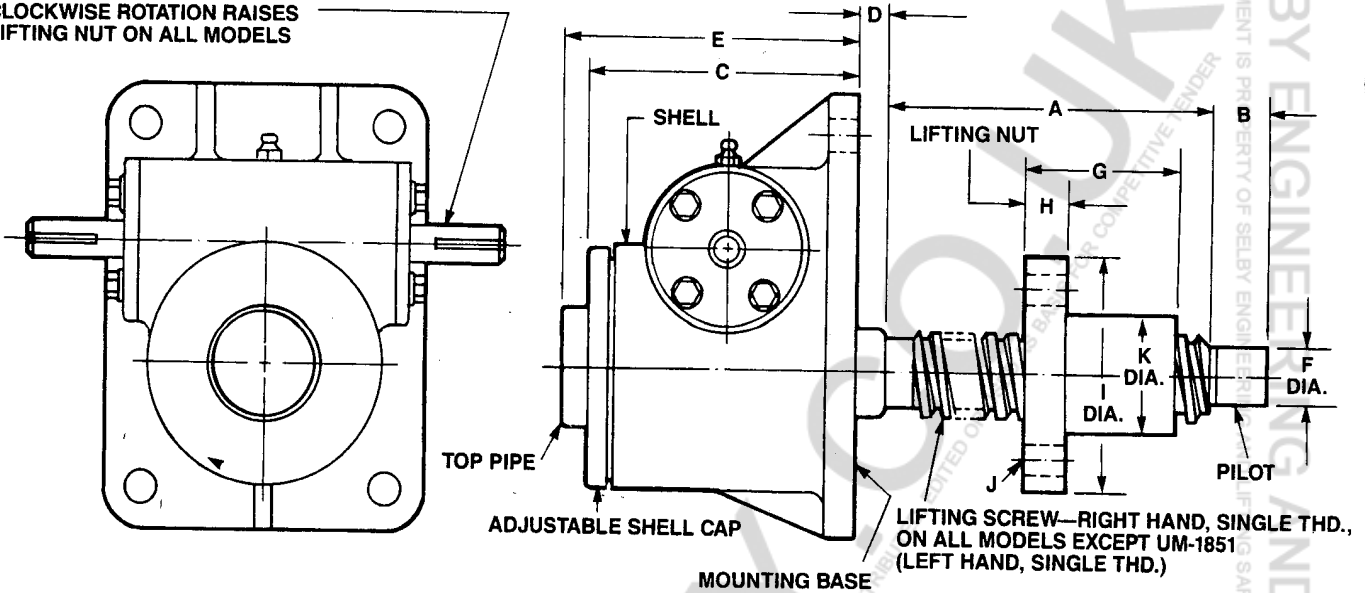

Table 4. Inverted Models

Model Number	Rating (Tons)	A (in.)	B (in.)	C (in.)	D (in.)	E (in.)	F (in.)	G (in.)	H (in.)	I (in.)	J (in.)	K (in.)
DM-1803	2	Raise + 2 3/8	3/4	3 3/4	5/8	C	.625	1 1/2	1/2	3 1/4	4 Holes - 13/32 Dia. On 2 3/8 Dia. B.C.	1 1/2
DM-9003	2	Raise + 2 3/8	3/4	3 3/4	5/8	C	.625	1 1/2	1/2	3 1/4	4 Holes - 13/32 Dia. On 2 3/8 Dia. B.C.	1 1/2
DM-9006	5	Raise + 3	1	5 1/4	2	C	1.000	2 1/2	3/4	4	4 Holes - 9/16 Dia. On 3 Dia. B.C.	2
DM-9011	10	Raise + 4	2	5 5/8	1 1/8	C	1.249	3	1	6	4 Holes - 13/16 Dia. On 4 1/2 Dia. B.C.	3
DM-9016	15	Raise + 4	2	5 1/2	13/16	6 1/2	1.500	3	1	6 1/2	4 Holes - 13/16 Dia. On 5 Dia. B.C.	3 1/2
DM-9021	20	Raise + 5	2 1/2	7 1/8	5/8	7 7/8	1.750	3	1	7 1/2	4 Holes - 15/16 Dia. On 5 1/2 Dia. B.C.	3 3/4
DM-9026	25	Raise + 7	3	8 7/8	1 1/2	9 7/8	2.500	5 1/2	1 1/4	8 1/2	4 Holes - 1 1/16 Dia. On 6 1/2 Dia. B.C.	4 1/2
DM-9036	35	Raise + 6	3 1/2	8 7/8	7/8	9 7/8	3.000	5 1/2	1 1/2	9	4 Holes - 1 1/16 Dia. On 7 Dia. B.C.	5
DM-1851	50	Raise + 7	4	10 7/8	2 5/8	11 1/2	3.500	6	2	10	6 Holes - 1 1/16 Dia. On 8 Dia. B.C.	6
DM-9076	75	Raise + 8 1/2	4 1/2	12 3/8	3 5/8	13 7/8	4.000	7 1/2	2	12 1/2	6 Holes - 1 1/8 Dia. On 10 Dia. B.C.	7
DM-9097	100	Raise + 8	5	17	2	18	5.000	7	2	14	6 Holes - 1 1/8 Dia. On 11 Dia. B.C.	8
DM-18151	150	Raise + 9 3/4	5 1/2	17	2	17	5.500	8 3/4	2 1/2	15 1/2	6 Holes - 1 1/2 Dia. On 12 1/2 Dia. B.C.	9

Note: All dimensions are in inches and subject to change without notice.

1-5. Important Precautions

To ensure that Duff-Norton® actuators provide reliable service over a period of years, the following precautions should be taken:

1. Select an actuator that has a load rating greater than the maximum load that may be imposed upon it.
2. The structure on which the actuators are mounted should have ample strength to carry the maximum load, and should be rigid enough to prevent undue deflection or distortion of the actuator supporting members.
3. It is essential that the actuators be carefully aligned during installation so that the lifting screws are perfectly plumb and the connecting shafts are exactly in line with the worm shafts. After the actuators, shafting, gear boxes, etc., are coupled together, it should be possible to turn the main drive shaft by hand. If there are no signs of binding or misalignment, the actuator

system is then ready for normal operation.

4. Actuators should have a greater raise than is needed in the actual installation. Should it be necessary to operate these actuators at the extreme limits of travel, it should be done cautiously.

Caution

Do not allow actuator travel to go beyond catalog closed height (A), or serious damage to lifting nut or the internal actuator mechanism may result. Refer to Dimensions (par. 1-4) for closed height (A) of respective units.

5. The worm shaft speed should not exceed 900 RPM for heavy loads or 1800 RPM for light loads of one-fourth (or less) of the actuator load rating for 500 and 1000 pound rated units. For units with a one-ton load rating, worm shaft speed should not exceed 1800 RPM.
6. The lifting screw should not be permitted to

accumulate dust and grit on the threads. If possible, screws should be protected by some means such as a boot.

Note

Rotating screws should never be run dry. Inspect frequently at regular intervals to be certain that a lubrication film is present.

Note

For loads of 25% to 100% of actuator capacity, torque requirements are approximately proportioned to the load.

7. These actuators are self-lowering and these units require a brake or other hold back device.
8. The lubrication procedures for normal and severe service conditions, as described in Section II paragraph 2-1, should be closely followed.

1-6. Warranty and Warranty Repair

Subject to the conditions stated herein, Duff-Norton will repair or replace, without charge, any parts proven to Duff-Norton's satisfaction to have

been defective in material or workmanship. Claims must be made within one year after date of shipment. Duff-Norton will not repair or replace any parts that become inoperative because of improper maintenance, eccentric loading, overloading, chemical or abrasive action, excessive wear, or other abuse.

Equipment and accessories not of Duff-Norton's manufacture are warranted only to the extent that they are warranted by the manufacturer, and only if the claimed defect arose during normal use, applications and service. Equipment which has been altered or modified by anyone without Duff-Norton's authorization is not warranted by Duff-Norton. EXCEPT AS STATED HEREIN, DUFF-NORTON MAKES NO OTHER WARRANTIES, EXPRESS OR IMPLIED, INCLUDING WARRANTIES OF MERCHANTABILITY AND FITNESS FOR A PARTICULAR PURPOSE.

If you have any questions concerning warranty repair, please contact Duff-Norton.

Authorization for return must be received from Duff-Norton before returning any equipment for inspection or warranty repair.

Section II Maintenance

2-1. Lubrication

Unless otherwise specified, actuators are shipped packed with grease which should be sufficient for one month of normal operation. For normal operation, the actuator should be lubricated once a month using Shell Albida LC EP2 grease, (Shell Product Code 70311).

This grease has been thoroughly evaluated in Duff-Norton actuators and has demonstrated superior lubricating properties affecting both wear life and maximum duty cycle. **Duff-Norton is not aware of an equivalent grease.** If this grease is not available in your area please contact your local supplier for their recommendations. Greases containing molybdenum disulfide should never be used.

For severe service conditions, the actuators should be lubricated more frequently using the above grease (daily to weekly depending upon the conditions). If duty is heavy, an automatic lubrication system is strongly recommended.

Note

Lifting screws should never be run dry. Inspect frequently at regular intervals to be certain that a lubrication film is present.

2-2. Rebuild Procedure

Duff-Norton recommends the following proce-

dures for assembly and disassembly of actuators.

1. Tag critical parts to facilitate reassembly.
2. Mark mating surfaces to ensure proper meshing.
3. Clean and lubricate all parts as required.
4. All seals must be replaced when rebuilding.
5. All screws, washers and other small common parts must be replaced if damaged in any way.
6. Replace damaged or frozen lubrication fittings with new ones.

2-3. Required Tools

A bearing puller and press, soft jaw table clamp and common hand tools are necessary for proper assembly and disassembly.

2-4. Disassembly (Refer to Figure 3-1)

1. Remove lifting nut (23) from screw (5)
2. Remove pipe (4) from shell (3) for upright units or shell cap (2) for inverted units.

Note

Upright and inverted 2-ton and 5-ton units and 10-ton inverted units are sealed with an expansion plug (4a) instead of a pipe (4). If necessary, these can be removed later.

3. For all models except 100 and 150-ton —
Remove set screw (1) from shell cap (2) and remove shell cap from shell (3).
For 100 and 150-ton models — Remove lock screw from shell (3) and remove base plate from shell (3).

Note

It may be necessary to tap on shell cap (2) or shell (3) with a hammer to loosen shell cap or base plate for removal.

4. Remove lifting screw (5) and gear (6) from shell (3). To allow gear and screw assembly to be removed more easily loosen cap screws (9) holding flanges (11) and shaft worm (14) slightly.

Note

On some units it may be necessary to remove worm (14) before removing screw and gear assembly. See steps 6 and 7.

5. Remove top bearing (7) which may be attached to either shell cap (2) or worm gear (6).
For 100 and 150-ton models - this will be the bottom load bearing (8) in base plate.

Note

If necessary, tap bearing loose with only a soft face hammer.

6. Remove cap screws (9), lockwashers (10) and remove flanges (11).

Note

Be careful not to lose flange shims (12).

7. Remove worm (14) and worm bearings (15) from shell (3) by striking end of worm shaft (14) with a soft face hammer.
8. Remove bottom load bearing (8), which may be attached to either shell (3) or gear (6).
For 100 and 150-ton models - this will be top load bearing (7).
9. Press oil seals (13) out of flanges (11).
10. Remove worm bearings (15) from worm (14) with puller or press.

Note

This step is not necessary if worm or worm bearings are not damaged.

11. Remove set screw (21) from locknut (20).

Note

Some models may not utilize set screw.

12. Restraining screw (5) from turning (use soft jaws), remove locknut (20) from screw (5).

Note

If all parts are to be reused, match-mark end of screw and locknut so that they can be reassembled in the same order.

13. Remove worm gear (6) from screw (5).

Note

It may be necessary to tap on worm gear. Use only a soft face hammer. Do not tap on gear teeth.

14. Remove key (22) from screw (5).
15. Inverted models - remove guide bushing (16) from shell (3).
100 and 150-ton models - remove guide bushing (16) from base plate.
16. For units with expansion plug (4a) in shell (3) or shell cap (2): if expansion plug is damaged and must be removed, drive or press plug out of shell (3) or shell cap (2) with a large die punch (1" diameter).

Disassembly is now complete.

2-5. Cleaning

1. Use degreasing solvent to remove grease or oil from all parts.

Note

Remove grease from unit and do not reuse old grease.



Warning

Provide adequate ventilation during the use of cleaning agent; avoid prolonged breathing of fumes and contact with skin. Read and follow manufacturer's instructions.

2. Use clean hot water or a soap solution for general cleaning of painted surfaces.
3. Dry parts thoroughly after cleaning.

Note

Before installing new parts, remove any rust preventive, protection grease, etc.

2-6. Inspection (Refer to Figure 3-1)

1. Make a visual inspection of shell (3) for broken, cracked or distorted areas. Check threads of all bores for burrs or broken threads.
2. Check shell cap (2), lifting screw (5), lifting nut (23) and worm gear (6) for burrs or scratches on their working or mating surfaces.
3. Check fit between rotating screw thread and internal thread of lifting nut. If fit is excessively loose, replace lifting nut or rotating screw as

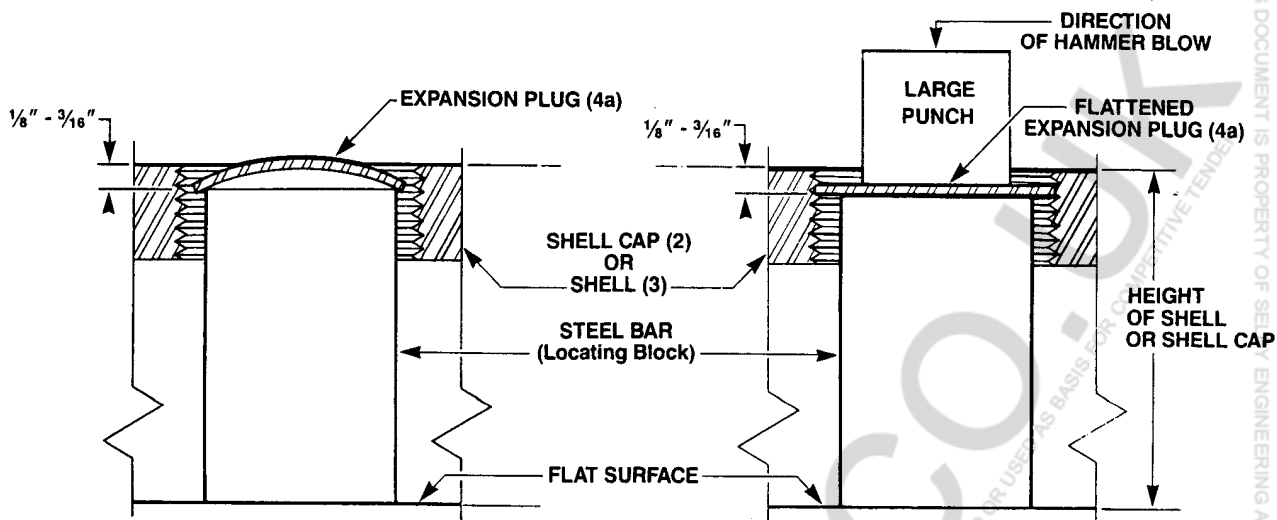

Figure 2-1. Expansion Plug Replacement

required.

4. Check small common components (screws, etc.) and replace as required.
5. Check bearings (7,8, 13 and 18) for seizure, galling or play and replace as required.

2-7. Assembly (Refer to Figure 3-1)

1. To replace expansion plug (4a) in 2 and 5-ton upright and 10-ton inverted units and in 10-ton inverted models; refer to Figure 2-1. For upright models, plug is installed in shell (3) (see Figure 3-1) and in shell cap (2) for inverted units (see Figure 3-1, Detail A).
 - a. As is appropriate, set shell cap (2) or shell (3) over a steel bar which is approximately 1/8" or 3/16" shorter in height than the shell or shell cap. The diameter of the bar should be close to the I.D. of the shell or shell cap.
 - b. Place expansion plug (4a) on the bar (concave surface down) and flatten the plug against the bar. Use a large diameter punch or press making sure that the plug is flattened throughout its entire diameter.
2. For models with tapered load bearings, press bearing cones on worm gear (6) with small end of cone facing away from gear surface. Be sure that cone is seated properly against shoulder.
3. Insert key (22) in screw (5).
4. Assemble worm gear (6) on screw (5). For counter-bored worm gears, counter-bore must face away from screw threads.
5. Thread locknut (20) onto screw (5) and turn tightly against gear (6). Be sure assembly is

tightly drawn together. Install set screw (21) in locknut (20) and lock in place (if rotating screw or locknut are new, respot screw for set screw).

Note

On some locknuts, the tapped set screw hole is not centered, and the locknut should be assembled with the tapped hole located as far as possible from the gear face.

6. Press worm bearings (15) onto worm (14), making certain that they are seated properly against the worm shoulder.

Note

When tapered roller bearings are used, the small end of the cone should point towards the end of the worm shaft.

7. Inverted units only. Install guide bushing (16) in shell (3). Guide bushing must be flush with base. Lock guide bushing in place by peening on the thread O.D. of the bushing and shell with a center punch.
8. Install bottom load bearing (8) [top load bearing (7) of 100 and 150-ton models] in shell (3).
9. Install worm (14) and bearing (or bearing cone) assembly (15) in shell. On units with tapered roller worm bearings, install bearing cups in shell.

Note

For some units, it is easier to assemble worm and bearing assembly after the worm gear is in place. (See Step 12).

10. Press oil seal (13) into flanges (11).

Note

The sealing element of the seal should face inward.

11. Assemble worm flanges (11) with shims (12) and bolt in place with cap screws (9) and lock-washers (10). This should be accomplished carefully to prevent cutting of seal on worm keyway.
12. Install screw (5) and worm gear (6).

Note

For some units it is easier to install worm and bearing assembly after gear and screw assembly are in place (see Step 9).

Note

After worm, worm gear and screw assembly are in place with flanges assembled, strike each end of worm shaft sharply with a soft face hammer to set bearing properly. Recheck flange bolts for tightness. Worm should turn freely with minimum drag and end play. If too much end play is present, remove shims as required. If worm does not turn freely, add shims as required.

13. Assemble top load bearing (7) [bottom load bearing (8) for 100 and 150-ton models] onto worm gear (6).

Note

For units with tapered load bearings, assemble bearing cup in shell cap (2) [base plate for 100 and 150-ton model].

14. Fill shell (3) approximately one half full of grease

and install grease fitting (17).

15. For all models except 100 and 150-ton - Install shell cap (2) and screw down until tight.

Note

Shell cap flange does not necessarily have to bear against top of shell. There will usually be a gap. This will put a slight drag on worm. If worm is hard to turn, back off slightly on shell cap.

For all 100 and 150-ton models - install base plate and screw down base plate until tight.

Note

This should put a slight drag on the worm. If the worm is hard to turn, back off slightly on the base plate. Be sure base plate does not project past base surface of housing.

16. Install set screws (1) in shell cap (2) [100 and 150-ton models install lock screw], locking shell cap (base plate) in place. Tap shell cap or base plate sharply with hammer and re-tighten set screw.

Note

If new parts have been installed, it may be necessary to re-spot holes for these screws.

17. For all units except those with expansion plugs, install pipe (4) in shell (3) for upright models (base plate for 100 and 150-ton units) or in shell cap (2) for inverted models (shell for 100 and 150-ton units).

18. Brush screw (5) with light film of grease and thread lifting nut (23) on screw (5). The face of lifting nut flange should be toward shell (2).

19. Operate unit by hand to insure proper functioning of all components prior to installation and use.

Assembly is now complete.

LIFTINGSAFETY.CO.UK
THIS DOCUMENT IS PROPERTY OF SELBY ENGINEERING AND LIFTING SAFETY LTD. UNDER NO CIRCUMSTANCES MUST THIS DOCUMENT BE REDISTRIBUTED, EDITED OR USED AS BASIS FOR COMPETITIVE TENDER

THIS PAGE IS BLANK

Section III Illustrated Parts List

3-1. General

This section contains an exploded illustration of the 2-ton and larger rotating machine screw actuators. The number adjacent to each part on the illustration is the index number. Keyed to this index number on the parts list is the part name.

Index No.	Part Name	Qty. Req.
1	Screw, Set (All models except 100 & 150 -ton)	2
2	Cap, Shell (All models except 100 & 150 -ton)	1
3	Shell, Actuator	1
4	Pipe, Bottom	1
4a	Expansion plug	1
5	Screw Assembly, Lifting	1
6	Worm Gear	1
7	Bearing, Top Load	1
8	Bearing, Bottom Load	1
9	Screw, Cap	8
10	Washer, Lock	8
11	Flange, Worm	2
12	Shim, Flange (.003 and .010)	2 Each
13	Seal, Oil	2
14	Worm	1
15	Bearing, Worm	2
16	Bushing, Guide (inverted model only)	1
18	Nameplate	1
19	Screws, Drive	2
20	Nut, Lock	1
21	Screw, Set	1
22	Key	1
23	Lifting Nut	1

When ordering spare parts be sure to include:

1. The nameplate model number of your actuator.
2. Index number and name of part.

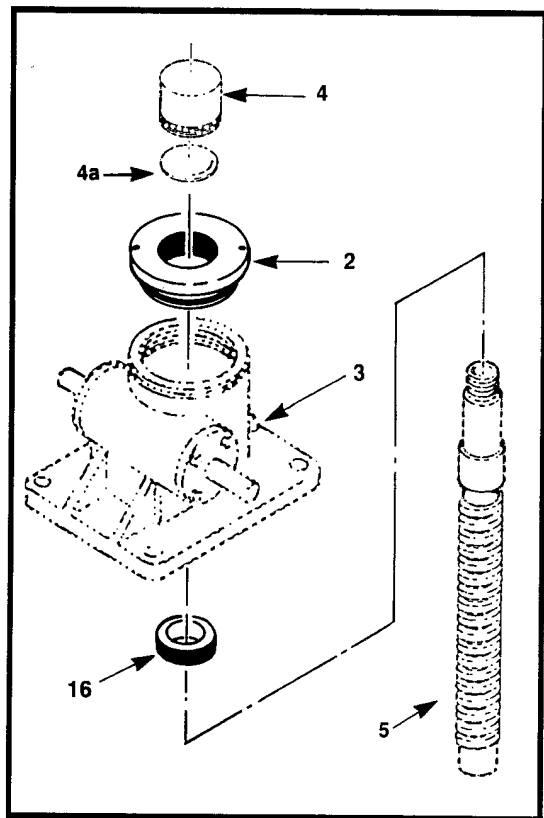

⚠ WARNING
Use only replacement parts supplied by or approved by Duff-Norton. Non-authorized parts may be inadequate, resulting in serious injury or death in event of failure.

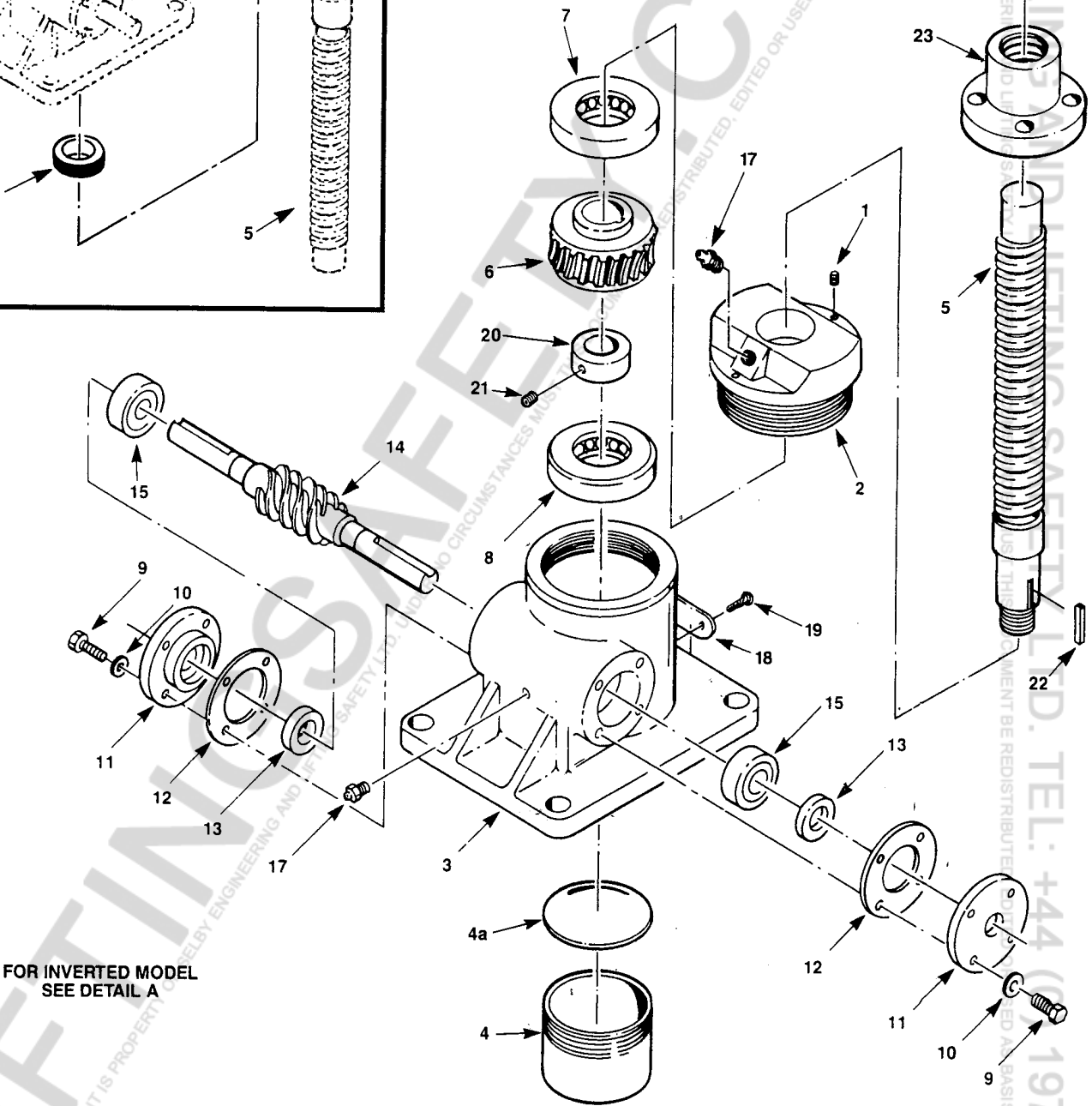

FOR INVERTED MODEL
SEE DETAIL A

Figure 3-1. Exploded Illustration 1800 and 9000 Series Rotating Machine Screw Actuators

LIFTINGSAFETY.CO.UK
PROPERTY OF SELBY ENGINEERING AND LIFTING SAFETY LTD. UNDER NO CIRCUMSTANCES MUST THIS DOCUMENT BE REDISTRIBUTED, EDITED OR USED AS BASIS FOR COMPETITIVE TENDER



 **Duff-Norton®**

P.O. Box 7010
Charlotte, NC 28241-7010

General Office (704) 588-0510
Customer Service (800) 477-5002
Customer Service (704) 588-4610
FAX (704) 588-1994