**OWNER'S (OPERATOR'S) MANUAL
AND SAFETY INSTRUCTIONS
FOR CB SERIES CHAIN HOIST (MODEL M3)**

BEFORE USING THIS PRODUCT :

ALWAYS SAVE THIS BOOK FOR FUTURE REFERENCE

ALWAYS READ OWNER'S (OPERATOR'S) MANUAL AND SAFETY INSTRUCTIONS

- ▲ WARNING** : **IMPROPER** chain hoist use could result in death or serious injury. To avoid these hazards:
- : **NEVER** hoist loads over or near people.
 - : **NEVER** work under or near hoisted loads.
 - : **ALWAYS** operate, inspect, and maintain this hoist in accordance with applicable safety codes and regulations.

These safety instructions contain important information to help you use the chain hoist in a safe manner. Please refer to this Owner's (Operator's) Manual for additional safety information.

 **KITO** CORPORATION

CONTENTS

DEFINITION	1
1. BEFORE USE	1
1.1 Safety Summary	1
1.2 Safety Instructions	2
2. MAIN SPECIFICATIONS	5
3. OPERATION	7
3.1 Safety Consideration	7
3.2 Operation	7
3.3 Hoist Storage	7
3.4 Principle and Operation of the Overload Limiter	7
4. INSPECTION	8
4.1 Outline	8
4.2 Daily Inspection	8
4.3 Periodic Inspection	9
5. MAINTENANCE	14
5.1 Lubrication	14
5.2 Overhaul, Assembly and Adjustment	15
6. WARRANTY	24
7. PARTS LIST	25

DEFINITION

⚠ WARNING : indicates a potentially hazardous situation which, if not avoided, could result in death or serious injury.

1. BEFORE USE

1.1 Safety Summary

Danger exists when heavy loads are transported, particularly when the equipment is not being used properly or is poorly maintained. Because accidents and serious injury could result, special safety precautions apply to the operation, maintenance and inspection of the Manual Chain Hoist.

Following these simple rules can help to avoid hoisting accidents;

⚠ WARNING : **IMPROPER chain hoist use could result in death or serious injury. To avoid these hazards:**

- NEVER** use a hoist for lifting, supporting or transporting people.
- NEVER** lift or transport loads over or near people.
- NEVER** work near or under hoisted loads.
- NEVER** lift more than rated load.
- ALWAYS** let people around you know when a lift is about to begin.
- ALWAYS** make sure that the supporting structures and load-attaching device are strong enough to hold the weight of the load and hoist.
- ALWAYS** read Owner's (Operator's) manual and safety instructions.

Remember, proper rigging and lifting techniques are the responsibility of the operator. Be sure to read and understand the instructions contained in this manual before using your hoist. Check all applicable safety codes, regulations and other applicable laws for further information about the safe use of your hoist.

More detailed safety information is contained in the following pages. For additional information, please contact Kito Corporation or your authorized Kito dealer.

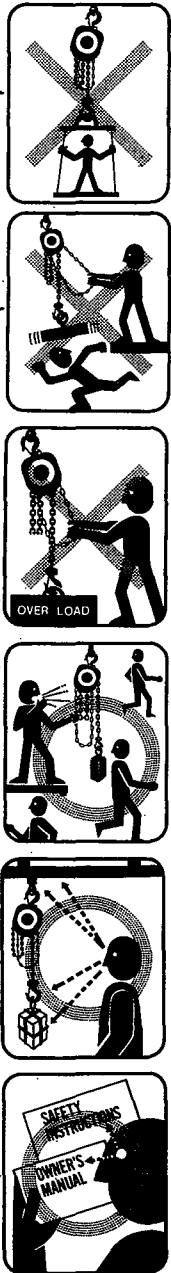

1.2 Safety Instructions

Serious injury could result if the following safety instructions are not followed.

⚠ WARNING : **IMPROPER chain hoist use could result in death or serious injury.**

To avoid these hazards:

“ALWAYSs”

- ALWAYS** make sure that you and others are clear of the load before lifting begins.
- ALWAYS** allow only qualified (trained in safety and operation) people to operate the hoist.
- ALWAYS** operate a hoist only if you are physically fit.
- ALWAYS** check the hoist before daily use according to the Recommended Daily Inspection (Refer to Sec. 4.2).
- ALWAYS** let the authorized personnel inspect the hoist periodically (Refer to Sec. 4.3).
- ALWAYS** make sure that the chain length is long enough for the intended job.
- ALWAYS** check that the hook latches are in proper working order before use (Refer to Sec. 4.3).
- ALWAYS** replace all missing or broken hook latches.
- ALWAYS** be sure that the hoist's rated capacity, which is found on the hoist's label, is well in excess of the weight of the load.
- ALWAYS** be sure that the load is properly seated in the saddle of the hook.
- ALWAYS** keep the load from hitting the chain.
- ALWAYS** use two hoists which have rated capacities equal to or more than the load to be lifted whenever you must use two hoists to lift a load. This will provide adequate protection in the event that a sudden load shift or failure of one hoist occurs.
- ALWAYS** check the brake before use (Refer to Sec. 4.3).
- ALWAYS** check for loose or missing parts before use.
- ALWAYS** lubricate the hoist regularly (Refer to Sec. 5.1).
- ALWAYS** pay attention to the load at all times when operating the hoist.
- ALWAYS** ease the slack out of the chain and sling when starting a lift to prevent a sudden loading.

- ALWAYS** secure a hoist and loads properly after use.
- ALWAYS** consult the manufacturer or your dealer if you plan to use a hoist in a dusty, moist or greasy environment.
- ALWAYS** consult the manufacturer or your dealer if you plan to use a hoist in an excessively corrosive environment.
- ALWAYS** operate the hoist with manual power.

⚠ WARNING : **IMPROPER chain hoist use could result in death or serious injury. To avoid these hazards:**

“NEVERs”

- NEVER** use the hoist to transport people. -----
- NEVER** lift a load over people.-----
- NEVER** work near or under hoisted loads.-----
- NEVER** operate a hoist if damaged or malfunctioning.-----
- NEVER** use a hoist which has been taken out of service until the hoist has been properly repaired or replaced.
- NEVER** use a hoist if the hook latch is missing or broken.-----
- NEVER** lift a load unless it is directly under the hook.
- NEVER** splice a hoist chain.
- NEVER** use non-authentic KITO chains on the hoist.
- NEVER** use the hoist chain as sling.-----
- NEVER** force a chain or hook into place by hammering.
- NEVER** jerk a load to prevent a sudden loading.
- NEVER** use a twisted, kinked, damaged or stretched load chain.-----
- NEVER** swing a suspended load.
- NEVER** support a load on the tip of the hook.-----

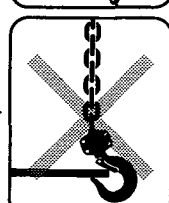
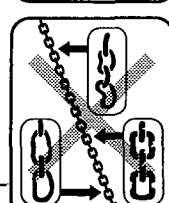
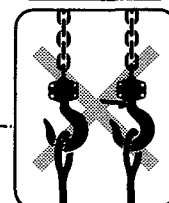
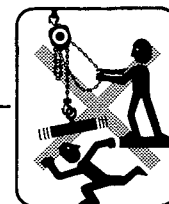
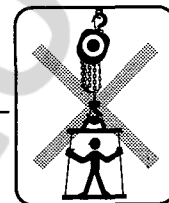

- NEVER** suspend a load for an extended period of time.
- NEVER** leave a suspended load unattended.
- NEVER** run the load chain over a sharp edge. -----
- NEVER** weld or cut a load suspended by a hoist.
- NEVER** use the hoist chain as a welding electrode.
- NEVER** use the hoist with rusty chain.
- NEVER** wind so far that the hook touches the block. -----
- NEVER** unwind so far that no unloaded chain is left. -----
- NEVER** operate a hoist if chain jumping, excessive noise, jamming, overloading or binding occurs. -----
- NEVER** use a hoist without chain stopper (or tail pin) at the end of no load side chain.
- NEVER** throw a hoist. -----
- NEVER** use a hoist without a name plate or warning tag and label or with illegible name plate, warning tag and label.
- NEVER** remove or obscure the warning tag. -----
- NEVER** use modified or deformed hooks.
- NEVER** use a motor to operate a manual hoist.
- NEVER** use a hoist near fire or where hot objects may touch it.
- NEVER** use the hoist in temperatures below $-40^{\circ}\text{C}(-40^{\circ}\text{F})$ or above $+60^{\circ}\text{C}(+140^{\circ}\text{F})$.
- NEVER** lift the bottom hook closer to the top hook than the minimum distance. (Refer to Sec. 2 : Dimensions table)

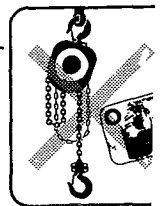
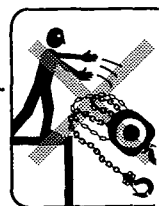
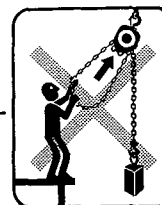
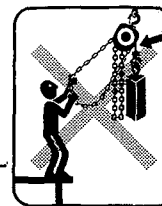
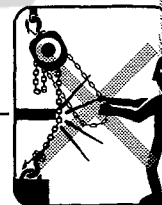

WARNING TAG is installed on a hand chain.

2. MAIN SPECIFICATIONS

Unit system is the metric one (SI unit system) in the following table.

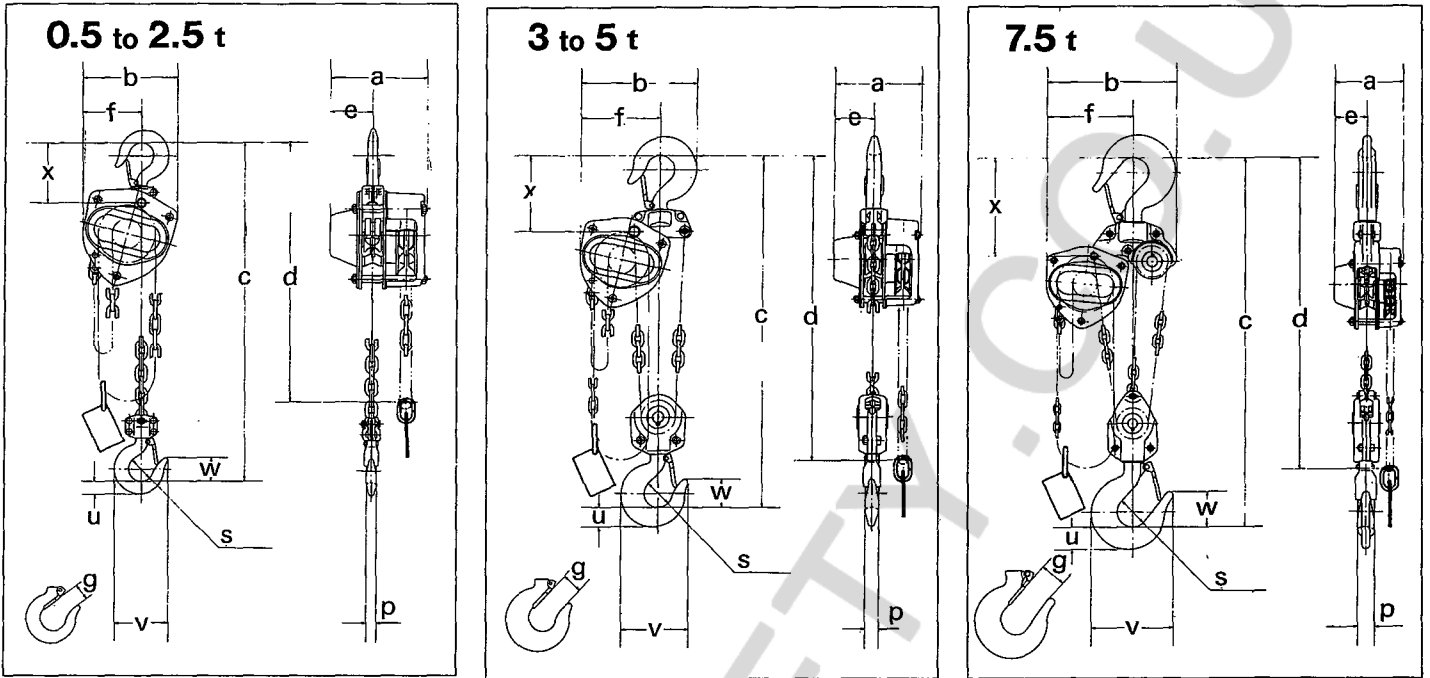

Specifications

Model	Code	Nominal Capacity (t)	Std. Lift (m)	Chain Pull to Lift Full Load (kg)	Chain O'hailed to Lift Load One Meter (m)	Test Load (t)	Net Weight (kg)	Shipping Weight (Approx) (kg)	Load Chain Dia.(mm) × Fall(lines)	Weight in kg for Additional One Meter of Lift (kg)
M3	CB005	0.5	2.5	24	25	0.75	10	10.5	5.0×1	1.5
M3	CB010	1	2.5	29	43	1.5	11.5	12	6.3×1	1.8
M3	CB015	1.5	2.5	35	57	2.36	14.5	15	7.1×1	2.1
M3	CB020	2	3.0	36	70	3	20	21	8.0×1	2.3
M3	CB025	2.5	3.0	33	99	3.75	27	28	9.0×1	2.7
M3	CB030	3	3.0	36	114	4.75	24	26	7.1×2	3.2
M3	CB050	5	3.0	34	198	6.3	41	43	9.0×2	4.4
M3	CB075	7.5	3.5	35	297	9.5	63	66	9.0×3	6.2

- Any lift of chain is available on request. Because KITO chains are specially heat-treated, only authentic KITO chains should be used on your hoist. **Never** attempt to lengthen your chain by attaching additional chain links with any other means. KITO can supply almost any length of chain desired. Simply specify the length of chain desired when ordering.

Dimensions

Model	Nominal Capacity (t)	Min. Distance between Hooks : C (mm)	a (mm)	b (mm)	d (m)	e (mm)	f (mm)	g (mm)	s (mm)	p (mm)	u (mm)	v (mm)	w (mm)	x (mm)
M3	0.5	285	158	161	2.5	69	99	27	35.5	12.1	17	77	35	89
M3	1	295	162	161	2.5	71	99	29	42.5	16	21.8	93	41	101
M3	1.5	350	171	182	2.5	78	112	34	47.5	19.5	26.5	106	47	119
M3	2	375	182	202	3	87	125	36	50	21.8	30	116	49	124
M3	2.5	420	192	233	3	91	143	40	53	24.3	33.5	127	53	136
M3	3	510	171	235	3.1	78	162	42.5	56	27.2	37.5	138	57	148
M3	5	600	192	282	3.6	91	194	46.5	63	34.5	47.5	161	67.5	172
M3	7.5	770	192	373	4.2	91	253	72.5	85	47.5	63	231	97.5	275

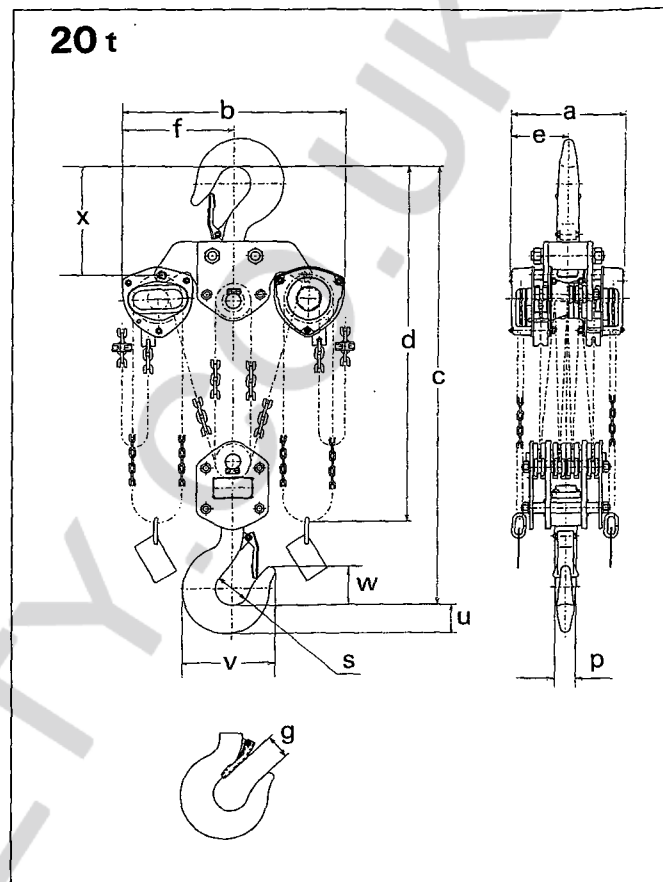
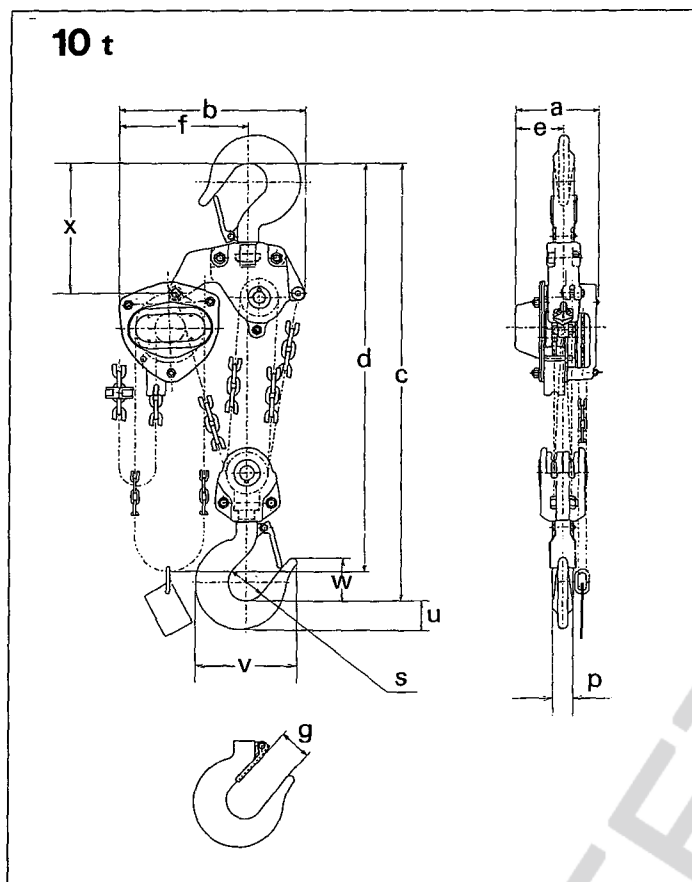

Specifications

Model	Code	Nominal Capacity (t)	Std. Lift (m)	Chain Pull to Lift Full Load (kg)	Chain O'hailed to Lift Load One Meter (m)	Test Load (t)	Net Weight (kg)	Shipping Weight (Approx) (kg)	Load Chain Dia.(mm) × Fall(lines)	Weight in l for Addition One Mete of Lift (kg)
M3	CB100	10	3.5	36	396	12.5	83	91	9.0 × 4	7.9
M3	CB150	15	3.5	37	594	20	155	165	9.0 × 6	11.4
M3	CB200	20	3.5	36 × 2	396 × 2	25	235	305	9.0 × 8	15.8

● Any lift of chain is available on request. Because KITO chains are specially heat-treated, only authentic KITO chains should be used on your hoist. **Never** attempt to lengthen your chain by attaching additional chain links with any other means. KITO can supply almost any length of chain desired. Simply specify the length of chain desired when ordering.

Dimensions

Model	Nominal Capacity (t)	Min. Distance between Hooks : C (mm)	a (mm)	b (mm)	d (m)	e (mm)	f (mm)	g (mm)	s (mm)	p (mm)	u (mm)	v (mm)	w (mm)	z (m)
M3	10	760	192	438	4.2	111	308	72.5	85	47.5	63	231	97.5	2
M3	15	1020	268	492	4.7	119	337	80	100	60	80	275	110	3
M3	20	1180	374	746	4.8	187	373	81	110	67	90	301	125	3

3. OPERATION

3.1 Safety Consideration

⚠ WARNING : Improper operation could result in death or serious injury. To avoid these hazards, only operate the chain hoist by hand. Power operation may result in structural damage or premature wear. This damage or wear may cause a part to break and cause the load to fall.

3.2 Operation

1. Face the hand chain wheel side of the hoist.
2. To raise the load, pull hand chain clockwise.
3. To lower the load, pull hand chain counterclockwise.

NOTE: The clicking sound of the pawl when a load is being raised indicates normal operation.

3.3 Hoist Storage

⚠ WARNING : IMPROPER chain hoist use could result in death or serious injury. To avoid these hazards:

ALWAYS store the hoist in no load condition.

ALWAYS wipe off all dirt and water.

ALWAYS oil the chain, top pin, chain pin and hook latches.

ALWAYS hang in a dry place.

ALWAYS check the hoist for abnormalities when using the hoist after a period of non-use according to the regular inspection procedures (Refer to Sec. 4.3).

3.4 Principle and Operation of the Overload Limiter (OPTIONAL)

⚠ WARNING : IMPROPER chain hoist use could result in death or serious injury. To avoid these hazards:

⚠ WARNING : NEVER disassemble or attempt to adjust the overload limiter assembly. Any attempt to do so will void the warranty. Contact your closest KITO Dealer, if service is required.

The overload limiter device has been developed to avoid overloading. When an applied load exceeds the preset value, the hand chain wheel rotates idly. The device is friction clutch mechanism which is concentrically equipped on pinion shaft between hand chain wheel and mechanical brake.

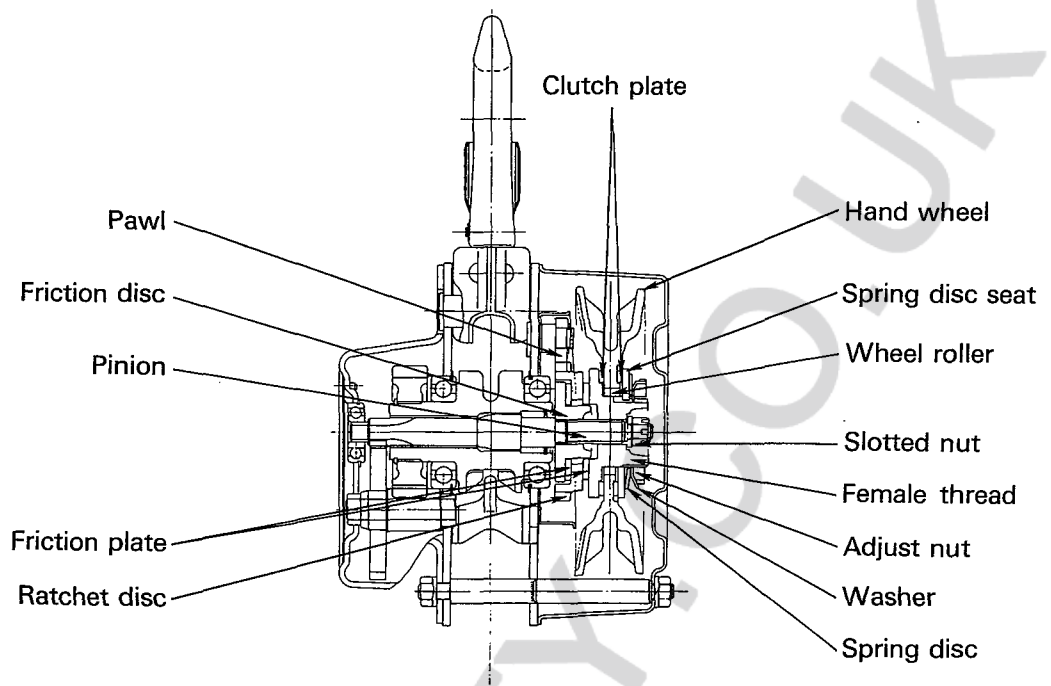

4. INSPECTION

4.1 Outline

There are two types of inspection, the daily inspection performed by the operator while using the hoist, and the more thorough periodic inspections performed by qualified personnel who have the authority to remove the unit from service.

4.2 Daily Inspection

Before each work shift, check the following points:

- (1) Check that the name plate showing the hoist capacity is attached and clearly legible.
- (2) Check that the warning tag and label are attached and clearly legible.
- (3) Check for visual defects or abnormal noises which could indicate a defect.
- (4) Check that the top and bottom hook latches are in place and in proper condition.
- (5) Make sure the openings of the top and bottom hooks are not too wide, that the swivel rotates freely and that the hook latch is in position and works normally.
- (6) Check for wear or damage, increased throat width, bent shank or bending of hook.
- (7) Check that the chain does not have excessive rust or corrosion and that it is not dry due to lack of lubricant.
- (8) When facing the hand chain side of the hoist with no load:
The brake is operating normally if the pawl "clicks" when the hand chain is wound in a clockwise direction and does not "click" when operated in the counter-clockwise direction.
- (9) Check lubrication and lubricate if necessary. (Refer to Sec. 5.1)

(10) Check that the chain is assembled normally and that there is no twisting.

(11) Check for loose or missing nuts and for missing split pins.

4.3 Periodic Inspection

Periodic inspections should be made at the interval shown below and should follow the given procedures.

NORMAL (Normal use): Semiannual inspection

HEAVY (Frequent use): Quarterly inspection

SEVERE (Excessively frequent use): Monthly inspection

<Periodic Inspection Procedure>

Figures in parentheses are Figure Nos. in Parts List.

Item	Inspection Method	Discard Limit/Criteria	Measures
Indications	Check visually.	○ Capacity indication is clear.	Attach the name plate.
HOOK [1, 6, 55, 78] (Top and Bottom)			
1. Deformation/ twist of hook opening	Measure dimension "e" between two embossed marks at time of purchase with calipers.	○ No deformation from original shape (at time of purchase).	Replace the hook.
	Check visually.	○ Twist shall not be large enough to detect visually.	Replace the hook.
2. Wear	Measure "c" and "d" with slide calipers.	○ Never use the hook if dimension "c" or "d" becomes less than 90 % of normal.	Replace the hook.

Table 1 (Reference dimensions)



Type (t)	a (mm)		b (mm)		c (mm)		d (mm)	
	Normal	Normal	Normal	Discard	Normal	Discard	Normal	Discard
1/2	31.0	27.0	17.0	15.3	12.1	10.9		
1	34.0	29.0	21.8	19.6	16.0	14.4		
1 1/2	37.5	34.0	26.5	23.9	19.5	17.6		
2	40.0	36.0	30.0	27.0	21.8	19.6		
2 1/2	42.5	40.0	33.5	30.2	24.3	21.9		
3	46.0	42.5	37.5	33.8	27.2	24.5		
5	50.0	46.5	47.5	42.8	34.5	31.1		
7 1/2	79.5	72.5	63.0	56.7	47.5	42.8		
10	79.5	72.5	63.0	56.7	47.5	42.8		
15	95.0	80.0	80.0	72.0	50.0	45.0		
20	95.0	81.0	90.0	81.0	56.0	50.4		

Item	Inspection Method	Discard Limit/Criteria	Measures																		
3. Hook flaws	Check visually.	○ No great damage permitted.	Replace the hook.																		
4. Hook movement	Turn hook.	○ Shall turn smoothly.	Replace the hook.																		
5. Top/bottom fixture damage [Fittings of 1,6,55, 78]	Check visually.	○ No slack or missing rivets, nuts or bolts.	Replace the hook.																		
6. Idle sheave rotation [57, 81]	Hold the load chain with both hands and turn the idle sheave by moving the chain up and down.	○ Smooth rotation.	Overhaul.																		
7. Hook latch [2, 7, 56, 80]	Check visually.	○ Proper positioning and smooth working.	Replace the latch or hook.																		
LOAD CHAIN [47, 110] 1. Wear	Measure with slide calipers.	○ Measure the sum of pitches of five chain links and check that the maximum length does not exceed value shown in table 2.	Replace the chain.																		
																					
Table 2																					
<table border="1" style="width: 100%; border-collapse: collapse;"> <thead> <tr> <th>Type (t)</th> <th>Sum of pitches of five links (mm)</th> <th>Discard limit (mm)</th> </tr> </thead> <tbody> <tr> <td>1/2</td> <td>75.5</td> <td>77.7</td> </tr> <tr> <td>1</td> <td>95.5</td> <td>98.3</td> </tr> <tr> <td>1 1/2, 3</td> <td>106.0</td> <td>109.1</td> </tr> <tr> <td>2</td> <td>121.0</td> <td>124.6</td> </tr> <tr> <td>2 1/2, 5, 7 1/2, 10, 15, 20</td> <td>136.0</td> <td>140.0</td> </tr> </tbody> </table>				Type (t)	Sum of pitches of five links (mm)	Discard limit (mm)	1/2	75.5	77.7	1	95.5	98.3	1 1/2, 3	106.0	109.1	2	121.0	124.6	2 1/2, 5, 7 1/2, 10, 15, 20	136.0	140.0
Type (t)	Sum of pitches of five links (mm)	Discard limit (mm)																			
1/2	75.5	77.7																			
1	95.5	98.3																			
1 1/2, 3	106.0	109.1																			
2	121.0	124.6																			
2 1/2, 5, 7 1/2, 10, 15, 20	136.0	140.0																			
2. Rust, flaws, deformation	Check visually.	○ No obvious rust (Apply oil as necessary.) ○ No twists or harmful flaws.	Remove rust. Replace the load chain.																		
HOOK YOKE (Top set [1, 54]) (Bottom set [6, 77]) Joint of Top/bottom fixtures with top pin [4] and chain pin [8, 106]	Measure hole diameter of joint area in two directions at right angle.	○ Deformation not permitted (if each measured value differs more than 0.5mm, it is not a circle).	Replace the part.																		

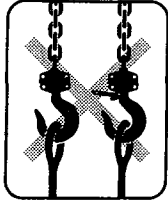
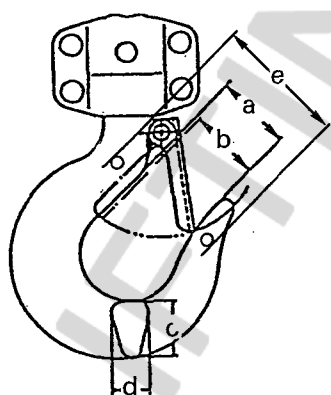
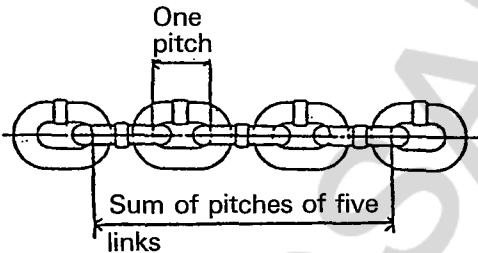
Item	Inspection Method	Discard Limit/Criteria	Measures
FUNCTION 1. Lifting and lowering 2. Brake	Lift and lower a light load.	○ No abnormal difficult in lifting or lowering. ○ Confirm that none of the problems listed below occur during lifting and lowering: <ul style="list-style-type: none"> • Lifting impossible. • Load falls when the operator removes his hands. • Load fall during unwinding. • Load slips down slowly. 	Overhaul and service. Overhaul and service.

BRAKE (Inside mechanism)	Overhaul and check.		
1. Flaws on brake surface [37,38,39] 2. Flaws on friction disc [36] 3. Wear on friction plate [37]	Check visually. Check visually. Measure with slide calipers.	○ No flaws due to scratching or gouging by foreign matter. ○ No flaws due to scratching or gouging by foreign matter. ○ Retain uniform thickness and friction plate shall not be worn more than 0.5 mm. For all types; Normal thickness: 3 mm Discard limit: 2.5 mm	Replace the part. Replace the part. Replace the part.

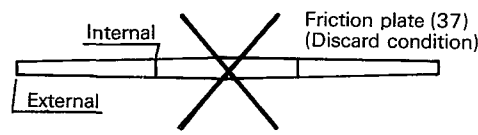
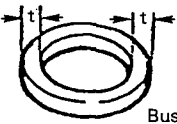
Item	Inspection Method	Discard Limit/Criteria	Measures									
4. Flatness of friction plate [37]	Check clearance with straight gauge.	<ul style="list-style-type: none"> ○ Clearance shall be uniform. ○ Internal part shall not be thicker than external part. 	Replace the part.									
5. Bushing [39]; wear and oil	Check radial thickness (t) with calipers and oil existence.	<ul style="list-style-type: none"> ○ Radial thickness (t) shall be uniform. ○ Oil shall be contained. ○ Refer to table 3. <p style="text-align: center;">Table 3</p> <table border="1" style="margin-left: auto; margin-right: auto;"> <thead> <tr> <th>Type (t)</th> <th>Normal thickness: t (mm)</th> <th>Discard limit (mm)</th> </tr> </thead> <tbody> <tr> <td>1/2, 1, 1 1/2, 3</td> <td>3</td> <td>2</td> </tr> <tr> <td>2, 2 1/2, 5, 7 1/2, 10, 15, 20</td> <td>4</td> <td>3</td> </tr> </tbody> </table>  <p style="text-align: center;">t:Radial thickness</p>	Type (t)	Normal thickness: t (mm)	Discard limit (mm)	1/2, 1, 1 1/2, 3	3	2	2, 2 1/2, 5, 7 1/2, 10, 15, 20	4	3	Replace the part.
Type (t)	Normal thickness: t (mm)	Discard limit (mm)										
1/2, 1, 1 1/2, 3	3	2										
2, 2 1/2, 5, 7 1/2, 10, 15, 20	4	3										
6. Ratchet disc [38]; wear and rust	Check visually.	<ul style="list-style-type: none"> ○ The tooth wear shall not be more than 1.5 mm. ○ No rust 	Replace the part.									

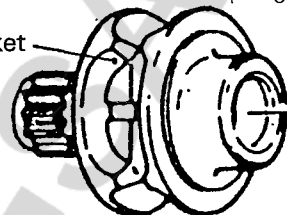
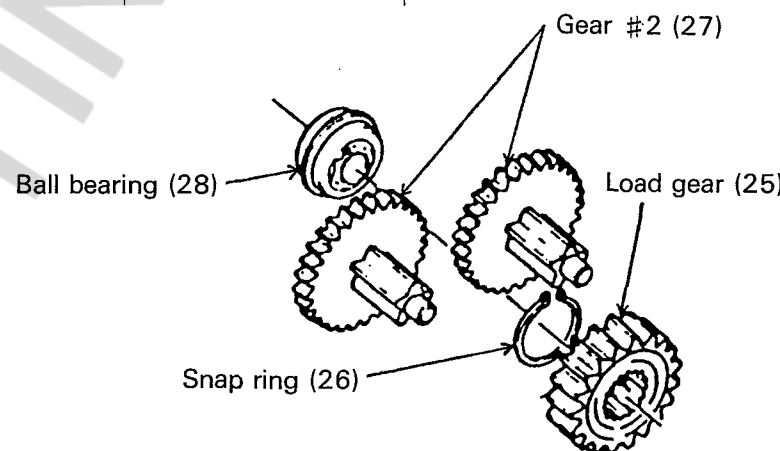
LIFTING SYSTEM			
1. Load sheave [14]; wear and deformation	Check visually.	<ul style="list-style-type: none"> ○ No large wear or no deformation or no burr due to load chain contact is permitted on the surface of load chain pocket.  <p style="text-align: center;">Load sheave (14)</p>	Replace the part.
2. Gears [25,27]; wear and flaw	Check visually.	<ul style="list-style-type: none"> ○ Teeth shall be free from large wear or flaws. 	Replace the part.

Item	Inspection Method	Discard Limit/Criteria	Measures
3. Hand wheel [40]; wear and deformation	Check visually.	<ul style="list-style-type: none"> ○ No large wear or no deformation on the surface of hand chain pocket. ○ Turn and check if it touches the cover. 	Replace the part. Replace the part.
<p>SIDE PLATES [11,13]</p> 1. Deformation of top pin hole 2. Slack stay bolt restraint	Check visually. Tap.	<ul style="list-style-type: none"> ○ Hole shall not be oval. ○ No slack is permitted. 	Replace the part. Replace the frame.
<p>The diagram shows a top hook (1) connected to a stay bolt. The stay bolt passes through side plate A (11) and side plate B (13). A top pin hole is also indicated on side plate B (13).</p>			
<p>MISCELLANEOUS</p> 1. Deformation of stripper [21] 2. Flaw on guide roller [20]	Check visually. Check visually.	<ul style="list-style-type: none"> ○ No large crush or damage on stripper tip is permitted. ○ Shall turn lightly. ○ No large deformation. 	Replace the part. Replace the part.

5. MAINTENANCE

⚠ WARNING : IMPROPER chain hoist use could result in death or serious injury.

To avoid these hazards:

- : NEVER perform maintenance on the hoist while it is supporting a load.
- : Before performing maintenance, attach the tag:
[“DANGER”: DO NOT OPERATE EQUIPMENT BEING REPAIRED.]
- : Only allow qualified service personnel to perform maintenance.
- : After performing any maintenance on the hoist, always test to its rated capacity before returning to service.

5.1 Lubrication

5.1.1 Applying Grease to Gears

Unscrew nuts (31), on the opposite side of hand chain wheel, and remove spring washers (32) and gear case (29). Remove old grease and replace with new grease (standard grease*), at annual inspection.

Temperature range of standard grease is -40°C (-40°F) to $+60^{\circ}\text{C}$ (140°F).

If the hoist is used at temperature below -40°C (-40°F) or above $+60^{\circ}\text{C}$ (140°F), consult the manufacturer or dealer since some parts shall be changed.

*Recommended brand : Shell Albania #3 or calcium soap grease equivalent of NLGI(National Lubricating Grease Institute)/ #3

5.1.2 Load Chain

⚠ WARNING : IMPROPER chain hoist use could result in death or serious injury.

To avoid these hazards:

- : Failure to maintain clean and well lubricated load chain will void the manufacturer's warranty.

ALWAYS lubricate load chain weekly, or more frequently, depending on severity of service.

ALWAYS lubricate more frequently than normal in a corrosive environment.*

ALWAYS use machine oil equivalent to ISO VG46 or 68.

ALWAYS clean chain with an acid free solvent only to remove rust or abrasive dust build-up. After cleaning, lubricate the chain.

ALWAYS lubricate each link of the chain and apply new lubricant over existing layer.

* A corrosion-resistant chain is available as option. For information on the capabilities and limitations of KITO's regular and corrosion-resistant chain, please ask your dealer.

5.2 Overhaul, Assembly and Adjustment

5.2.1 Overhaul

Figures in parentheses are Figure Nos. in Parts List.

Overhaul Procedures	Remarks
<ol style="list-style-type: none"> 1. Put a hoist with wheel cover side up. 2. Unscrew three nuts [45] (with the spring washers [46]) fixing the wheel cover [44] and remove the wheel cover from the side plate A [11]. 3. Remove the hand chain [48] from the hand wheel [40]. 4. Pull out the split pin [43] from the wheel stopper pin [42] and remove the wheel stopper pin and the wheel stopper [41] from the pinion [17]. 5. Remove the hand wheel [40] from the pinion [17] by turning the hand wheel counterclockwise. 6. Remove two friction plates [37], the ratchet disc [38] and the bushing [39] from the friction disc [36]. 7. Unscrew the friction disc [36] from the pinion [17] by turning counterclockwise holding the end of the pinion with fingers. 8. Remove the snap ring [35] from the pawl pin (on the side plate A) and then remove the pawl [34] and pawl spring A and B [33]. 9. <For 7½ t and smaller types> Pull the split pin [24] out from the stopper pin [23] and remove the load chain [47] and the stopper pin from the anchorage [22]. <For 10 t and larger types> Pull the split pin [52] out from the end pin [51] and remove the load chain [47] and the end pin. Unscrew two socket bolts (with the spring washers) fixing the stoppers [114] and remove the stoppers. 10. Remove the load chain [47] from the load sheave [14] by pulling the load chain toward the bottom hook. 11. Remove the split pin [5] from the top pin [4], then remove the top pin and the top hook [1] from the side plate A [11] and B [13]. 12. Put a hoist with gear case side (or name plate side) up. 	<p>If the hand wheel is too tight to turn by hand, put the hand chain on the hand wheel back again and pull it down hard. It will release the brake.</p>

Overhaul Procedures	Remarks
<p>13. Unscrew three nuts [31] (with the spring washers [32]) fixing the gear case [29], remove the gear case from the side plate B [13], and take the ball bearings [28] out from the gear case.</p> <p>14. Remove two pairs of the gear # 2 [27] (1/2 t has one pair) from the side plate B [13].</p> <p>15. Remove the snap ring [26] from the load sheave [14], then the load gear [25] from the load sheave.</p> <p>16. Remove the side plate B [13] from the side plate A [11] and then take the ball bearing [16] out from the side plate B.</p> <p>17. Remove the guide rollers [20], load sheave (attached to the pinion [17]), stripper [21] and anchorage [22] (For 10 t larger types: cross guide [53]) from the side plate A [11], then remove the ball bearing [15] from the side plate A.</p> <p>18. Remove the snap ring [19] in the load sheave [14].</p> <p>19. Remove the pinion [17] and the roller bearing [18] from the load sheave [14].</p> <p>20. Pull the split pin [10] out from the slotted nut [9] and remove the slotted nut and chain pin from the bottom hook [6].</p>	<p>Hold the load sheave with a hand and remove the bearing by tapping the pinion with a wooden hammer.</p>

5.2.2 Assembly and Adjustment

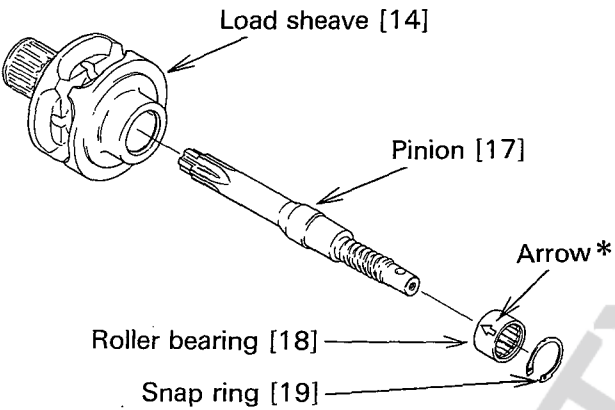
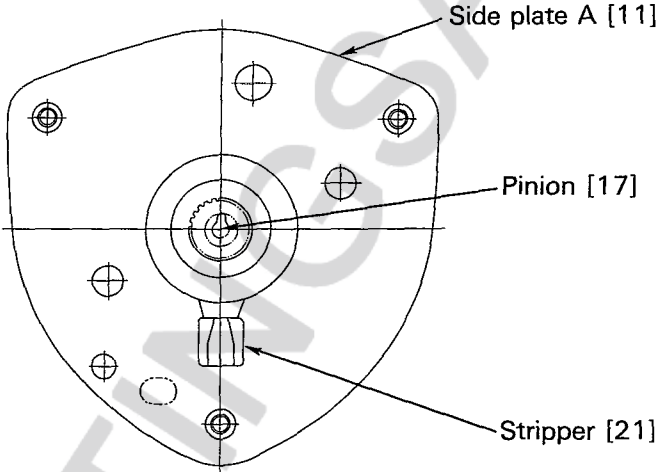
Assembly Procedures	Remarks
<p>1. Apply grease to the rollers of the roller bearing [18] and insert the pinion [17] (from the side of the brake screw) into the roller bearing and insert them together into the load sheave [14]. Fix them with a snap ring [19].</p> 	<p>The arrow* direction on the outer side of the roller bearing shall be faced to pinion gear side. When inserting, use a screwdriver on the bearing and tap it with a wooden hammer.</p> <p>⚠ WARNING Always make sure that the snap ring is correctly seated.</p>
<p>2. Put the side plate A [11] with a brake cover side down and insert the ball bearing [15] (with a snap ring side up) into the side plate A. Grease the balls of ball bearing shown in the side plate A.</p> <p>3. Insert the load sheave [14] with a part of involute serration side (pinion gear side) up into the ball bearing [15]. The stripper [21] must be put as well.</p>	
	
<p>4. <For 7½ t and smaller types> Put the guide rollers [20] and the anchorage [22] in the side plate A [11]. <For 10 t and larger types> Put the guide rollers [20] and the cross guide [53] in the side plate A [11].</p>	<p>Put the cross guide so that the longer arm fits to the side plate A.</p>

Assembly Procedures	Remarks
---------------------	---------

5. Grease the balls of the ball bearing [16].
Insert it with the snap ring side down to the shaft of the load sheave [14].

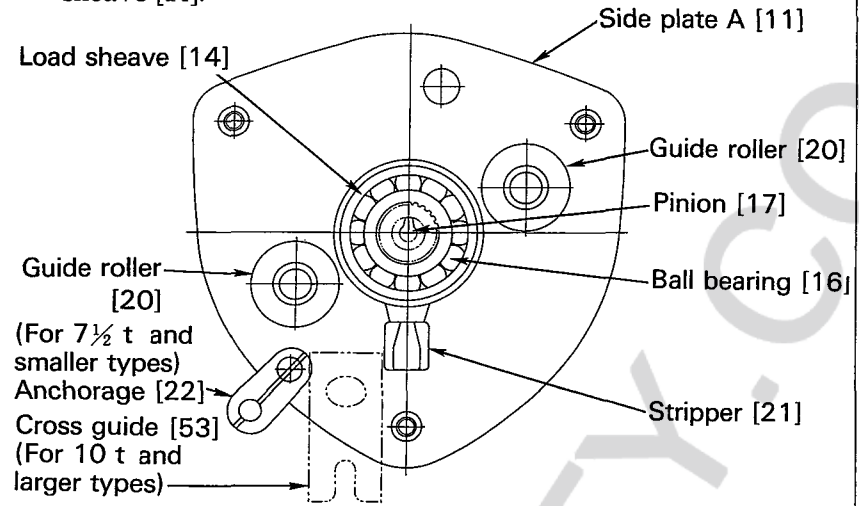

As for the ball bearing of the load sheave, make sure that the snap ring is placed on the side of the load sheave where the load chain reeves.

6. Join the side plate B [13] to the side plate A [11].

In case it is difficult to join the two, tap it with a wooden hammer. Be careful not to let the stripper, guide roller, and anchorage fall down.

7. Mesh the load gear [25] with the involute serration of the load sheave [14] and fix it with a snap ring [26].

⚠ WARNING
Always make sure the snap ring is completely set at the bottom of the ditch.

8. Grease the two pairs of the gear # 2 [27], the load gear [25] and the gear of the pinion [17]. Put them in the gear plain bearing (bearing A) of the side plate B [13]. Letters O and V on the gears must face to each other as shown in the below picture. Do not forget to apply grease to the boss on the both sides of the gear #2.

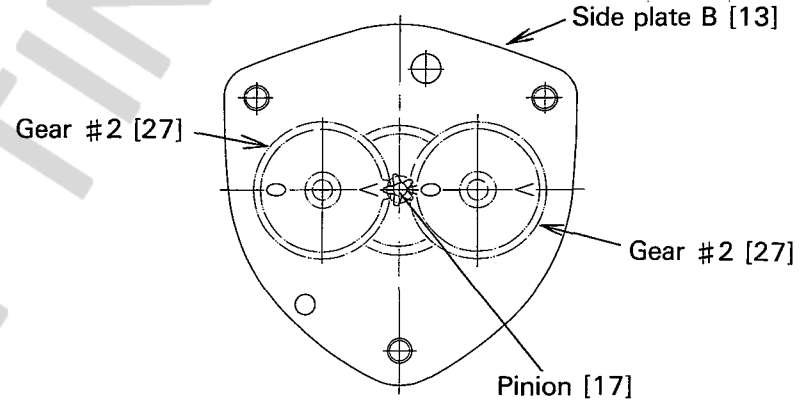

It is not necessary to adjust the letters in case of the 1/2 t model, for it has only one pair of the gear #2.

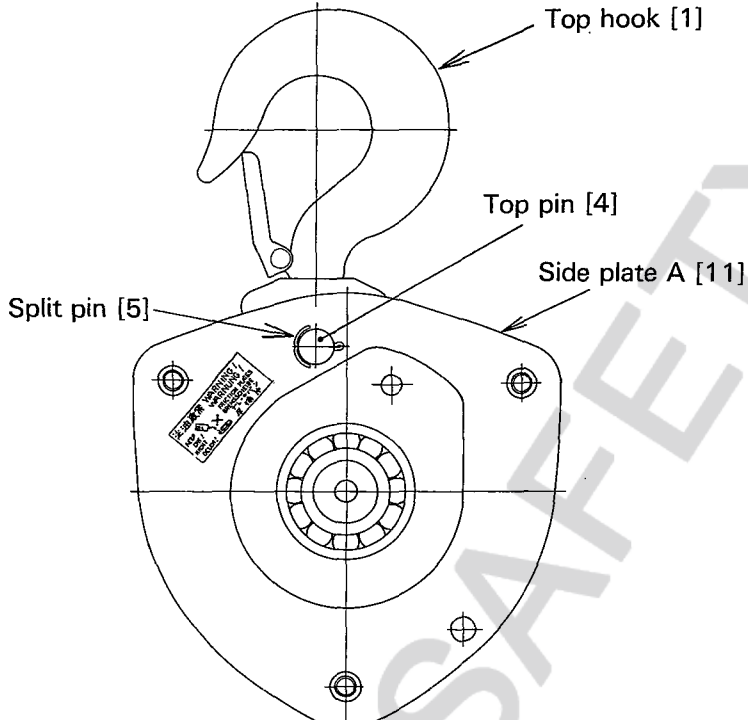
Assembly Procedures	Remarks
<p>9. Grease the balls of the ball bearing [28] and insert it with the snap ring down into the end of the pinion [17] shaft.</p> <p>10. Join the gear case [29] to the side plate A [11] and fix them with the three spring washers [32] and nuts [31].</p> <p>11. Place the top hook [1] between the side plate A [11] and B [13]. Then insert top pin [4], and fix it with the split pin [5].</p>	<p>⚠ WARNING Always bend the split pin firmly after inserting it into the top pin.</p>
 <p>12. Place the hand wheel [40] side upward.</p>	

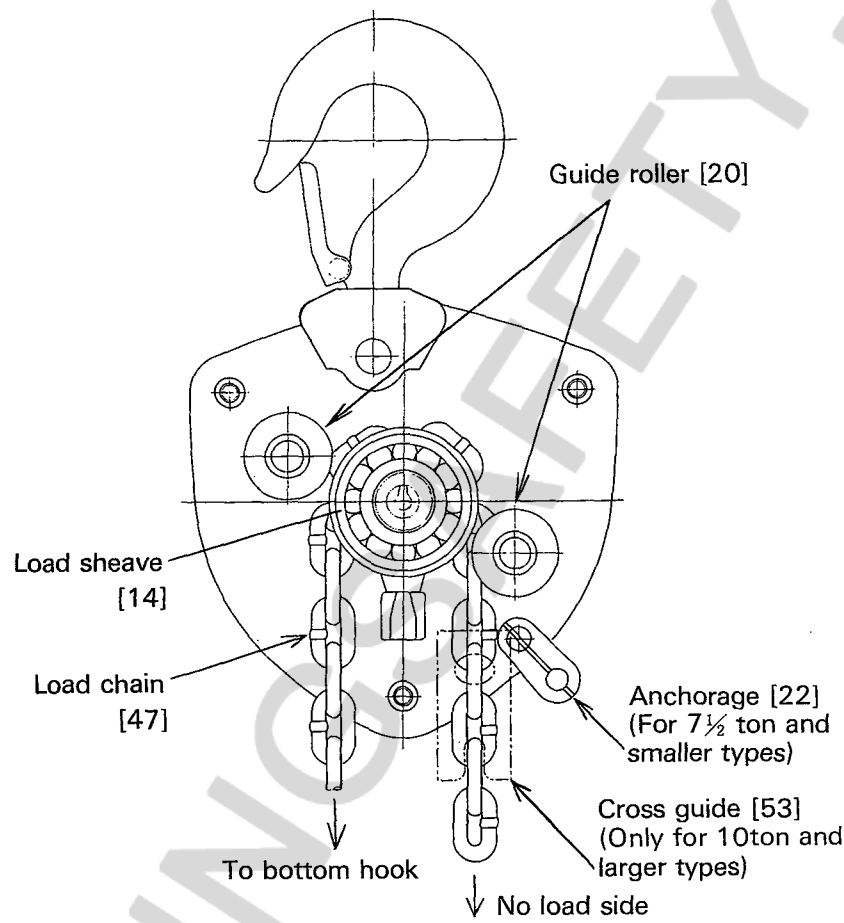
Assembly Procedures	Remarks
<p>13. Reeve the load chain [47] turning the pinion [17] shaft clockwise through the space between the left (bottom hook side) guide roller [20] and the load sheave [14].</p> <p>For 10 t or larger hoists, pass the no load end of the chain through the cross guide [53].</p> 	<p>⚠ WARNING</p> <p>Put the welded part of the vertical chain link outward and reeve it through the load sheave. Pull it out between the right guide roller (no load side) and the load sheave.</p> <p>It is recommended for this process to position the unit so that the side plate A [11] faces left and the side plate B [13] faces right.</p>

Assembly Procedures

Remarks

14. <For 7½ t and smaller types>

Pull the end of the load chain [47] out between the right guide roller [20] and the load sheave [14] (no load side) and insert it to the anchorage [22]. Insert the stopper pin [23] and fix it with a split pin [24].

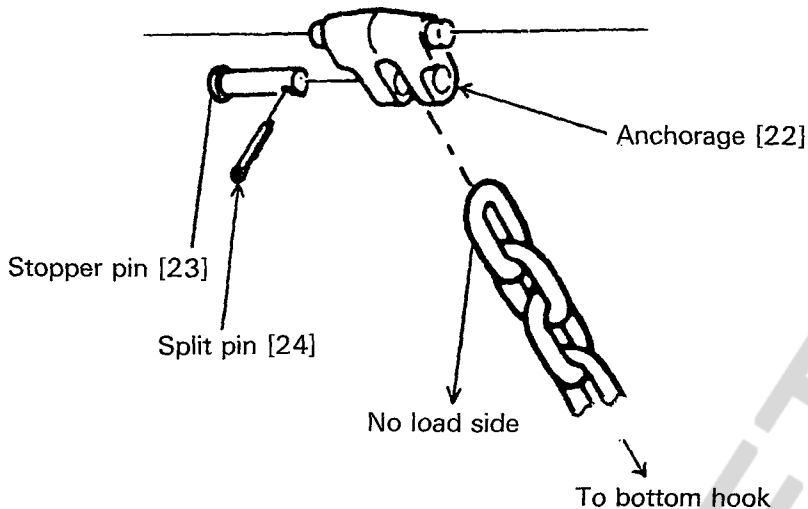

<For 10 t and larger types>

Connect the no load end of the load chain [47] to end pin [51] which is to be inserted from gear case [29] side.

Use a split pin [52] to secure the end pin.

Fix stoppers [114] to the ninth link from the no load end of the load chain by assembling with socket bolts and spring washers.

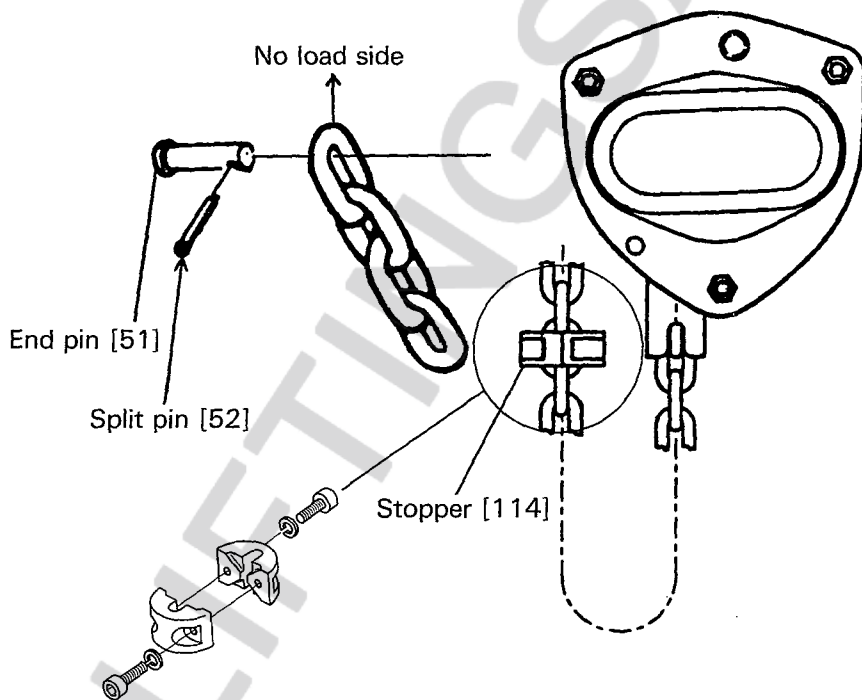

⚠ WARNING

Make sure the load chain is not twisted and the split pin in the stopper pin is bent thoroughly.

Screwed hole side of one stopper shall face to non-screwed hole side of the other stopper. Socket bolt shall be inserted from the non-screwed side.

Assembly Procedures	Remarks
<p>15. Apply machine oil to the pawl pin (in side plate A [11]) and join the pawl spring A,B [33] and the pawl [34] respectively to it. Fix them with a snap ring [35].</p>	<p>⚠ WARNING Make sure the pawl spring is touching to the pawl and the snap ring is completely set at the bottom of the groove.</p>
<p>16. Put the friction disc [36] to the pinion [17] shaft (while turning the pawl [34] counterclockwise).</p>	
<p>17. Wipe out any dirt on the friction disc [36], friction plates [37] and both sides of the ratchet disc [38] and check if the oil of the bushing [39] (bushing with containing oil) is applied enough. Then place the friction plate, bushing, ratchet disc and friction plate respectively on the friction disc. (Make sure that the pawl meshes with the ratchet disc properly)</p>	<p>⚠ WARNING Never apply oil since the brake is 'dry system'. Wipe out thoroughly any oil and dirt on the brake. The gear of the ratchet disc should point at the pawl. Otherwise, the hand wheel cannot be assembled later. In case the bushing does not have oil inside, soak it in tarbin oil for a day. Install it in without wiping the oil.</p>
	<p>Make sure that the pawl meshes with the ratchet disc properly.</p>
<p>18. Wipe out the dirt of the hand wheel [40] and apply machine oil to the threaded part of it. Screw it in the pinion [17] shaft all the way down.</p>	
<p>19. Place the wheel stopper [41] on the head of the pinion [17], insert the wheel stopper pin [42] and fix it with a split pin [43].</p>	<p>⚠ WARNING Never forget to bend the split pin after inserting into the wheel stopper pin.</p>

Assembly Procedures	Remarks
<p data-bbox="172 280 861 313">20. Put the hand chain [48] around the hand wheel [40].</p> <div data-bbox="215 336 909 1187"> </div> <p data-bbox="164 1220 986 1294">21. Join the wheel cover [44] to the side plate A [11] and fix them with the spring washer [45] and the nut [46].</p> <p data-bbox="164 1317 986 1422">22. Insert the other end of the load chain [47] to the bottom hook [6] and fix them with the chain pin [8], slotted nut [9] and split pin [10].</p> <div data-bbox="175 1444 973 1937"> </div>	<p data-bbox="1034 1299 1236 1339">⚠ WARNING</p> <p data-bbox="1034 1355 1356 1422">Always bend surely the split pin.</p>

6. WARRANTY

Kito Corporation ("Kito") extends the following warranty to the original purchaser ("Purchaser") of new products manufactured by "Kito"(Kito's Products).

- (1) "Kito" warrants that Kito's Products, when shipped, shall be free from defects in workmanship and/or materials under normal use and service and "Kito" shall, at the election of "Kito", repair or replace free of charge any parts or items which are proven to have said defects, provided that all claims for defects under this warranty shall be made in writing immediately upon discovery and, in any event, within one (1) year from the date of purchase of Kito's Products by "Purchaser" and provided, further, that defective parts or items shall be kept for examination by "Kito" or its authorized agents or returned to Kito's factory or authorized service center upon request by "Kito".
- (2) "Kito" does not warrant components of products provided by other manufacturers. However to the extent possible, "Kito" will assign to "Purchaser" applicable warranties of such other manufacturers.
- (3) Except for the repair or replacement mentioned in (1) above which is "Kito"'s sole liability and purchaser's exclusive remedy under this warranty, "Kito" shall not be responsible for any other claims arising out of the purchase and use of Kito's Products, regardless of whether "Purchaser"'s claims are based on breach of contract, tort or other theories, including claims for any damages whether direct, indirect, incidental or consequential.
- (4) This warranty is conditional upon the installation, maintenance and use of Kito's Products pursuant to the product manuals prepared in accordance with content instructions by "Kito". This warranty shall not apply to Kito's Products which have been subject to negligence, misuse, abuse, misapplication or any improper use or combination or improper fittings, alignment or maintenance.
- (5) "Kito" shall not be responsible for any loss or damage caused by transportation, prolonged or improper storage or normal wear and tear of Kito's Products or for loss of operating time.
- (6) This warranty shall not apply to Kito's Products which have been fitted with or repaired with parts, components or items not supplied or approved by "Kito" or which have been modified or altered.

THIS WARRANTY IS IN LIEU OF ALL OTHER WARRANTIES, EXPRESS OR IMPLIED, INCLUDING BUT NOT LIMITED TO ANY WARRANTY OF MERCHANTABILITY OR OF FITNESS FOR A PARTICULAR PURPOSE.

7. PARTS LIST

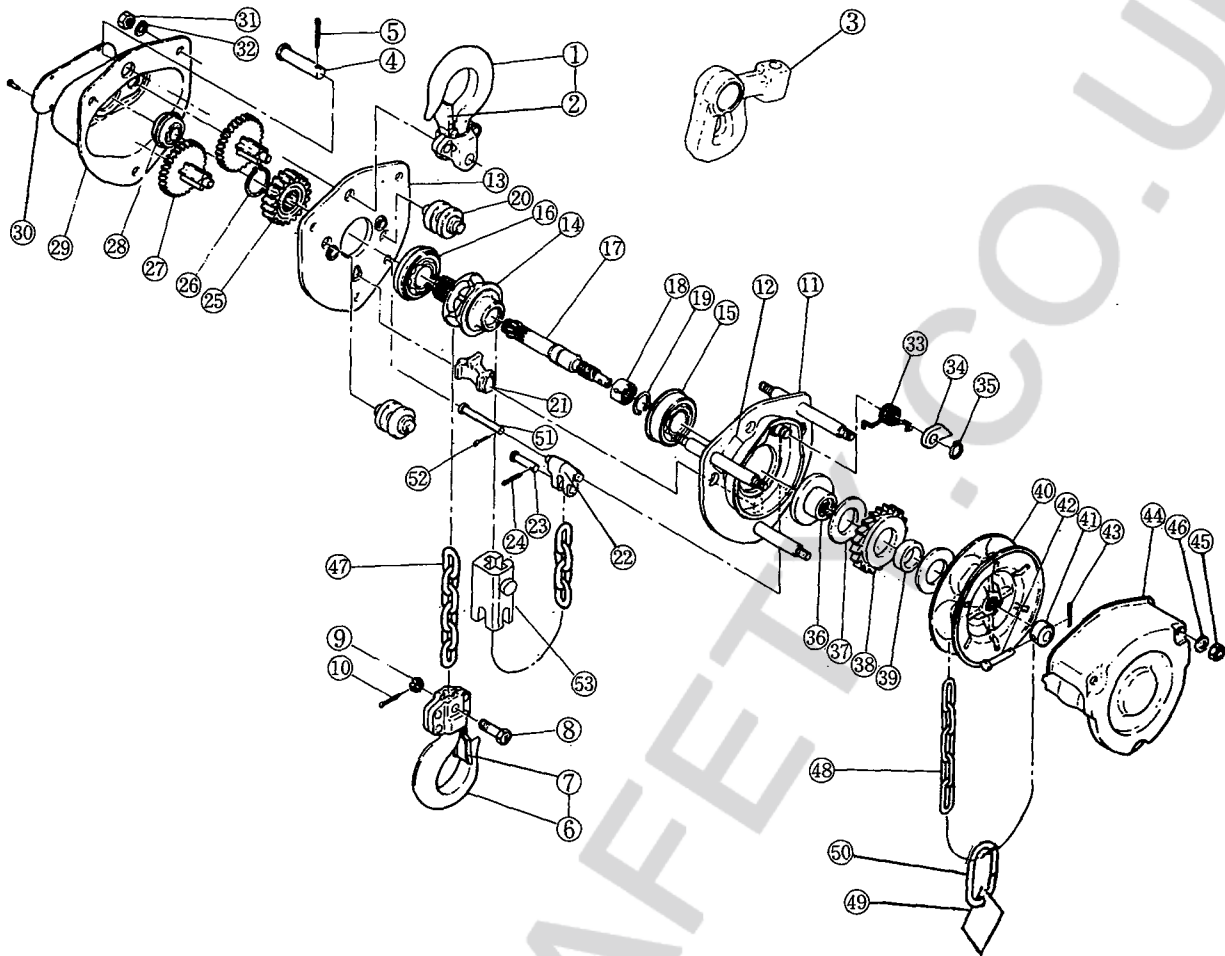

ADDITIONAL PARTS FOR 3 t AND LARGER TYPES

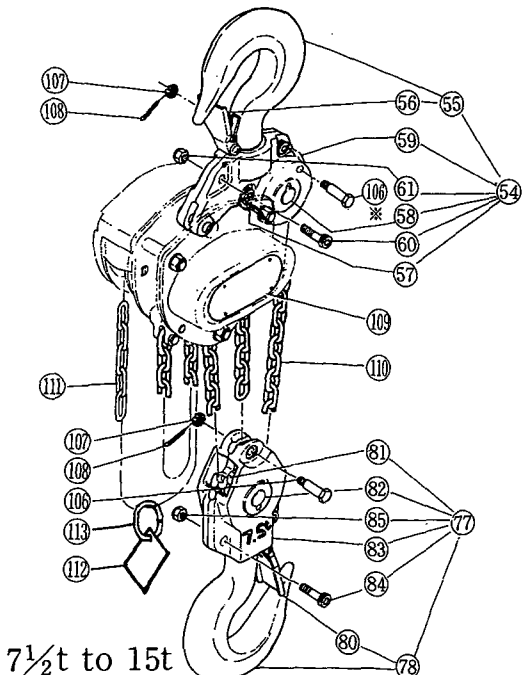
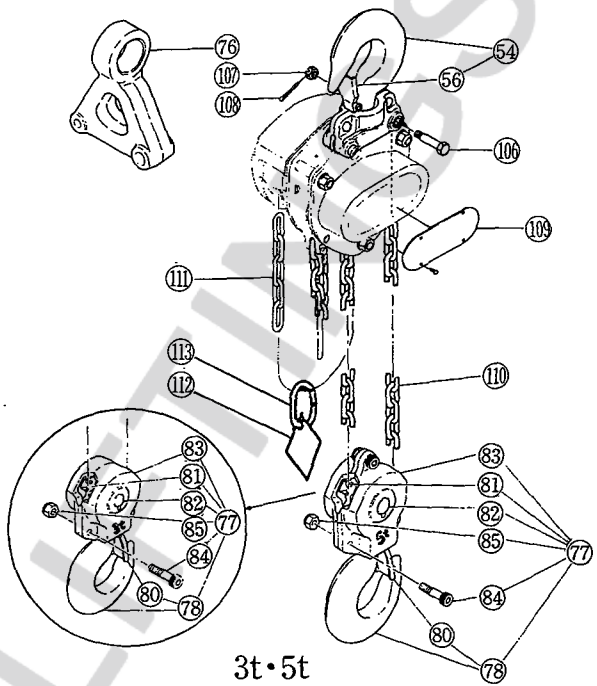

※ The Chain pin of 10t model is located on top yoke to connect the Load chain.

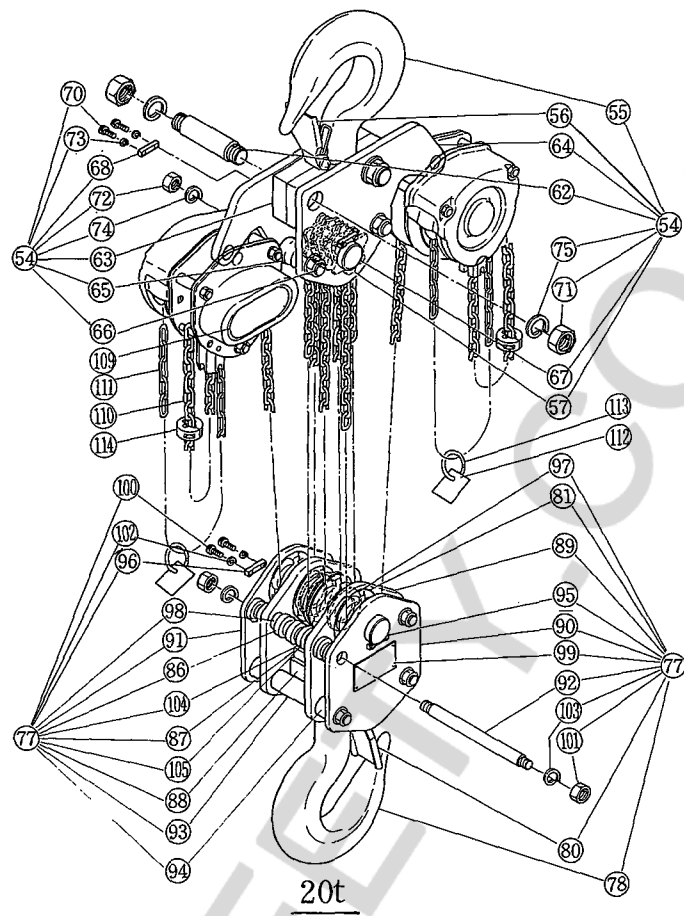

Fig. No.	Part No.	Part Name	Parts per Hoist	Capacity Code										
				005	010	015	030	020	025	050	075	100	150	200
①	M3-001A	Top hook set	1											
2	M3-071A	Hook latch assembly	1											
③	*	Suspender for TSP005	1											
	*	Suspender for TSG010	1											
	*	Suspender	1											
④	M3-163	Top pin	1											
⑤	M3-198	Split pin	1											
⑥	M3-021A	Bottom hook set	1											
7	M3-071A	Hook latch assembly	1											
⑧	M3-041	Chain pin	1											
⑨	M3-049	Slotted nut	1											
⑩	M3-096	Split pin	1											
⑪	M3-101 ⁽¹⁾	Side plate A assembly	1											
12	M3-806	Name plate F	1											
⑬	M3-102 ⁽¹⁾	Side plate B assembly	1											
⑭	M3-116	Load sheave	1											
⑮	M3-140	Ball bearing	1											
⑯	M3-145	Ball bearing	1											
⑰	M3-111 ⁽¹⁾	Pinion	1											

*see trolley parts lists.

TEL: +84(0)1977 684 600

Fig. No.	Part No.	Part Name	Parts per Hoist	Capacity Code											
				005	010	015	030	020	025	050	075	100	150	200	
18	M3-130	Roller bearing	1												
19	M3-118	Snap ring	1												
20	M3-161	Guide roller	2												
21	M3-162	Stripper	1												
22	M3-176	Anchorage	1												
23	M3-177	Stopper pin	1												
24	M3-196	Split pin	1												
25	M3-114	Load gear	1												
26	M3-117	Snap ring	1												
27	M3-112 ⁽¹⁾	Gear #2 assembly	⁽³⁾	1	2	2		2					2		
28	M3-135	Ball bearing	1												
29	M3-103	Gear case assembly	1												
30	M3-800 ⁽¹⁾	Name plate B with rivets	1												
31	M3-181	Nut	3												
32	M3-186	Spring washer	3												
33	M3-179	Pawl spring A ⁽²⁾	1												
	M3-180	Pawl spring B ⁽²⁾	1												
34	M3-155	Pawl	1												
35	M3-157	Snap ring	1												
36	M3-153 ⁽¹⁾	Friction disc	1												
37	M3-151 ⁽¹⁾	Friction plate	2												
38	M3-152 ⁽¹⁾	Ratchet disc	1												
39	M3-154 ⁽¹⁾	Bushing	1												
40	M3-115 ⁽¹⁾	Hand wheel	1												
41	M3-159	Wheel stopper	1												
42	M3-167	Wheel stopper pin	1												
43	M3-199	Split pin	1												
44	M3-171	Wheel cover assembly	1												
45	M3-182	Nut	3												
46	M3-187	Spring washer	3												
47	M3-841	Load chain	1												
48	M3-842	Hand chain	1												
49	M3-931	Warning tag	1												
50	M3-045	Chain stopper link	1												
51	M3-164	End pin	1												
52	M3-197	Split pin	1												
53	M3-176	Cross guide	1												

Note : (1) When ordering replacement part, use the symbol M3B in place of M3 for 2.5t, 5t and larger types, because there are no interchangeability.

(2) Pawl spring A and B must be used as a set.

(3) Each number in "Capacity Code" columns is parts per hoist.

Remark : Every part quantity becomes twice of the number in the column "Parts per hoist" for 20t hoist.

Fig. No.	Part No.	Part Name	Parts per Hoist	Capacity Code					
				030	050	075	100	150	200
⑤④	M3- 001A	Top hook set	1						
55	M3- 001	Top hook	1						
	M3- 001	Top hook assembly	1						
56	M3- 071A	Hook latch assembly	1						
57	M3- 051	Idle sheave assembly	☆ ⁽³⁾			1	1	2	3
58	M3- 053	Shaft assembly	1						
59A	M3- 011	Top yoke A	1						
	M3- 016	Top yoke A	1						
59B	M3- 012	Top yoke B	1						
	M3- 017	Top yoke B	1						
60	M3- 081	Socket bolt	☆ ⁽³⁾			3	1		
61	M3- 082	Lever nut	⁽³⁾			3	1		
—	M3- 086	Socket bolt	2						
—	M3- 087	U nut	2						
62	M3- 010	Top suspension shaft	2						
63	M3- 011	Top yoke	2						
64	M3- 012	Top plate A assembly	⁽³⁾					1	2
—	M3- 014	Top plate B	1						
65	M3- 018	Guide	⁽³⁾					4	6
66	M3- 019	Stay bolt	2						
—	M3- 043	Top plate	1						
67	M3- 053	Top shaft	1						
68	M2- 056	Key plate	2						
—	M3- 066	Collar	2						
70	M3- 083	Socket bolt	4						
71	M3- 084	Nut	4						
72	M3- 085	Nut	4						
73	M3- 087	Spring washer	4						
74	M3- 088	Spring washer	4						
75	M3- 089	Spring washer	4						
⑦⑥	*	Suspender for TSP & TSG	1						
⑦⑦	M3- 021A	Bottom hook set	1						
78	M3- 021	Bottom hook	1						
	M3- 021	Bottom hook assembly	1						
80	M3- 071A	Hook latch assembly	1						
81	M3- 051	Idle sheave assembly	⁽³⁾	1	1			3	4
	M3- 052	Idle sheave assembly	2						
82	M3- 053	Shaft assembly	1						
	M3- 054	Bottom shaft assembly	1						
83	I.13- 031	Bottom yoke	2						
84	M3- 081	Socket bolt	☆ ⁽³⁾	2	3	2			

*see trolley parts lists.

Fig. No.	Part No.	Part Name	Parts per Hoist	Capacity Code					
				030	050	075	100	150	200
84	M3- 088	Socket bolt	2						
85	M3- 082	Lever nut	(3)	2	3	2			
	M3- 087	U nut	1						
86	M3- 018	Guide	(3)					6	8
87	M3- 026	Hook support	2						
88	M3- 030	Bottom yoke	1						
89	M3- 034	Bottom plate A	(3)					1	2
90	M3- 035	Bottom plate B	1						
91	M3- 036	Bottom plate C	1						
92	M3- 038	Stay-bolt	4						
93	M3- 039	Collar A	2						
94	M3- 040	Collar B	4						
95	M3- 054	Bottom shaft	1						
96	M2- 056	Key plate	2						
97	M3- 058	Washer A	2						
98	M3- 066	Collar	4						
99	M3- 069	Name plate A with rivets	1						
100	M3- 083	Socket bolt	4						
101	M3- 085	Nut	8						
102	M3- 087	Spring washer	4						
103	M3- 088	Spring washer	8						
104	M3- 091	Tongued washer	4						
105	M3- 092	Bolt	4						
(106)	M3- 041	Chain pin	1						
(107)	M3- 049	Slotted nut	1						
(108)	M3- 085	Split pin	1						
	M3- 097	Split pin	1						
(109)	M3- 800 ⁽¹⁾	Name plate B with rivets	(3)	1	1	1	1	1	2
(110)	M3- 841	Load chain	1						
(111)	M3- 842	Hand chain	(3)	1	1	1	1	1	2
(112)	M3- 931	Warning tag	(3)			1			2
(113)	L4- 045	Chain stopper link	(3)			1			2
(114)	M3- 045	Stopper assembly	(3)				1		2

Note : (1) When ordering replacement part, use the symbol M3B in place of M3 for 2.5t, 5t and larger types, because there are no interchangeability.

(3) Each number in "Capacity Code" columns is Parts per hoist.

ASSEMBLY FOR OVERLOAD LIMITER

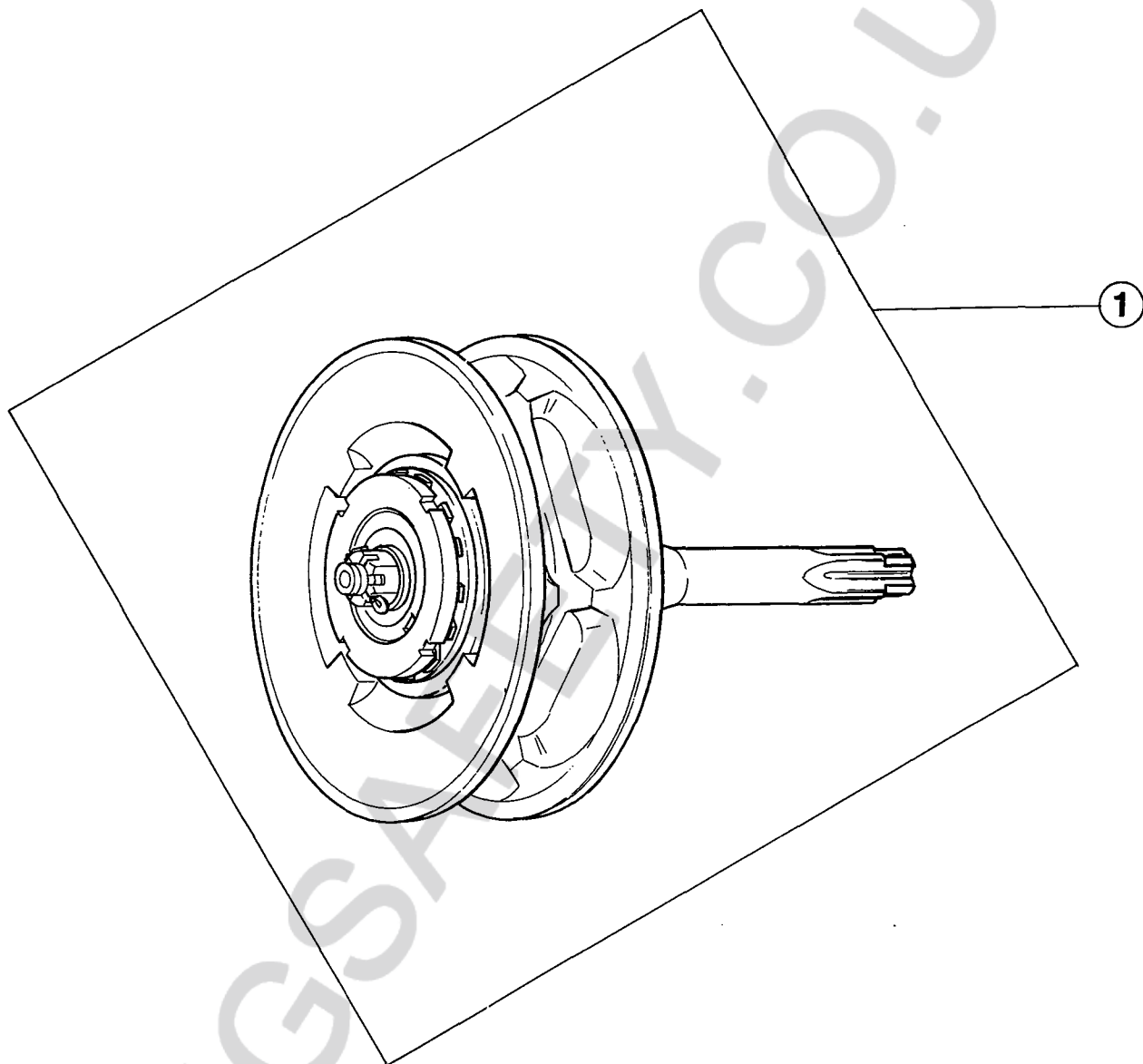

Fig. No.	Part No.	Part Name	Parts per Hoist	Capacity Code				
				005	010	015 030	020	025 100 050 150 075 200
①	M3-111A ⁽¹⁾	OLL Kit	1					

Note : (1) When ordering replacement part, use the symbol M3B in place of M3 for 2.5t, 5t and larger types, because there are no interchangeability.

Remark : Every part quantity becomes twice of the number in the column "Parts per hoist" for 20t hoist.



KITO CORP.

Tokyo Opera City Tower 16F,
3-20-2 Nishi-Shinjuku, Shinjuku-ku,
Tokyo 163-1416, Japan

Tel. : 03-5371-7341

Fax. : 03-5371-7349

E-mail : overseas@kito.co.jp

URL : <http://www.kito.co.jp>

LIFTINGSAFETY.CO.UK