

SELBY ENGINEERING AND LIFTING SAFETY LTD. TEL: +44 (0) 1977 684 600



I.R.E.P S.A.S  
59450 Sin le Noble - France  
Tel.: +33 (0) 27 93 08 08  
Fax: +33 (0) 27 93 08 00

Copyright © 2008. Ingersoll-Rand Company  
All Rights reserved.

# LIFTCHAIN LC2A Series Model LC2A250Q...

## Hook Mount 25 Tons Lifting capacity

IREP Drawing Number	Rev.
08/04/22-L645	A
Customer Drawing Number	
Folio :	1/1
Engineering Mgr. Approval : JLF	

### Standard Features :

- Rugged and Compact modular design
- Design temperature -20°C
- Explosion proof - 100% duty rating - No downtime
- Gear type air motor with high starting torque providing long life
- Variable speed control at pilot pendant or pull chain
- Top and bottom limit switches intergrated in hoist body for better protection
- Automatic fail safe disc brake (no adjustment required)
- Zinc plated load chain for corrosion resistance
- Exhaust muffler for quiet operation
- Sound pressure level < 84 dBA
- Suitable for horizontal pulling applications
- Low maintenance cost
- Individually load tested before shipment

*It is strongly recommended to use a lubricating and a filtration system on the compressed air line.  
The compressed air temperature must not exceed 65°C at the motor air inlet.  
For higher temperature, please consult us.*

### Options:

- Overload protection device adjusted at factory during load tests
- Main air emergency stop at pendant as per EN 418
- Spark resistant package for ATEX zone 1
- Chain containers
- Marine or offshore paint including sandblasting
- Trolley mount versions (plain, geared or motorized)
- Mining versions and hydraulic versions available

### Ex classifications (ATEX)

- Standard version is suitable for Zone 2 (ATEX Marking Ex II 3 GD c IIB 135°C x)
- Optional spark resistant package is suitable for Zone 1 (ATEX marking Ex II 2 GDc IIB135°Cx)

### FEM classification

- Driving mechanism classification 1Bm

### Built in ISO 9001 certified factory

### Technical data at 6.3 bar

Model	LC2A250Q
Rated Capacity (metricTon)	25
Falls of chain	4
Lifting speed at rated load (m/min)	0.5
Lifting speed at no load (m/min)	0.9
Lowering speed at rated load (m/min)	0.6
Working pressure range (Bar)	4 to 7
Air consumption at rated load (m <sup>3</sup> /min)	5
Minimum headroom (mm)	1156
Air inlet (BSP)	3/4
Chain size (mm)	16x45
*Weight with std lift (Kg)	324
Chain Weight per meter of lift (kg)	23

*\*Net weight is given with standard lift of 3m and standard control length of 2m*

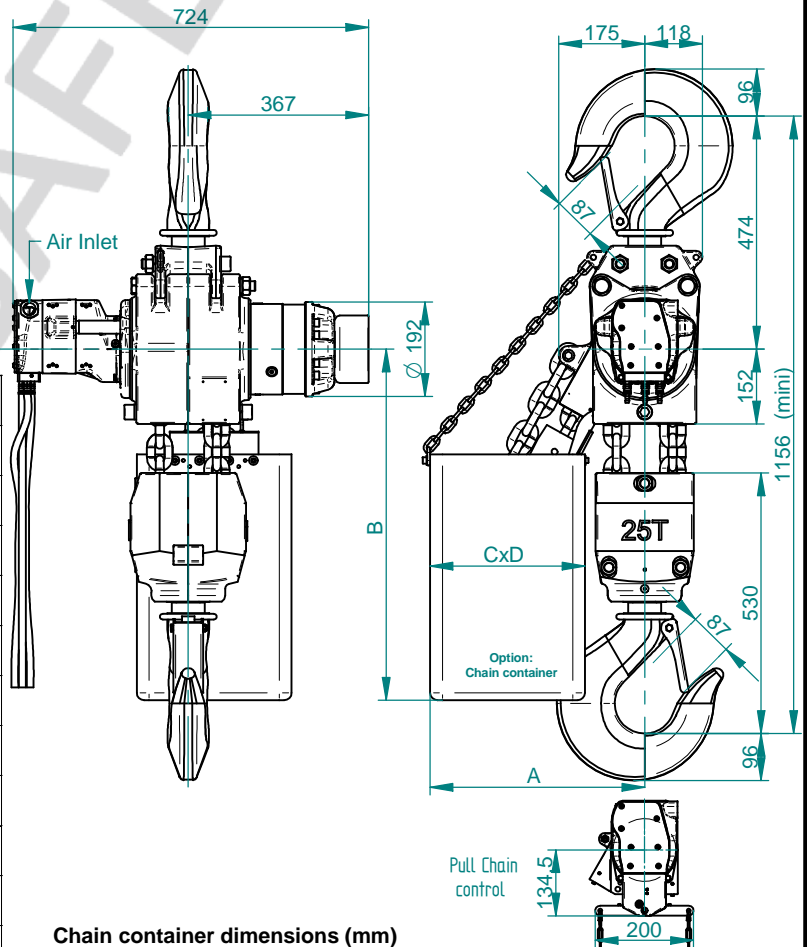
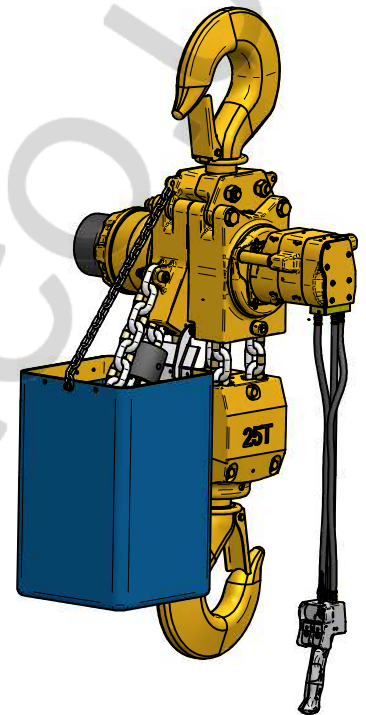

### Chain container dimensions (mm)

Height of lift	A	B	CxD	Option code
3m	435	715	315x315	A
6.5 m	525	915	400x400	B
10 m	525	915	550x400	C

The equipment described on this sheet is subject to the general sales and warranty conditions of Ingersoll-Rand company. Because of the constant evolution of technology, Ingersoll-Rand company reserves the right to modify without notice the specifications contained in this document.