

SELBY ENGINEERING AND LIFTING SAFETY LTD. TEL: +44 (0) 1977 684 600



# LIFTINGSAFETY

SELBY ENGINEERING AND LIFTING SAFETY LTD

Tel: +44 (0) 1977 684 600 Email: sales@liftingsafety.co.uk

**LIFTING EQUIPMENT AND HEIGHT SAFETY SPECIALISTS**

automatic hook system

## *It's that simple ...*

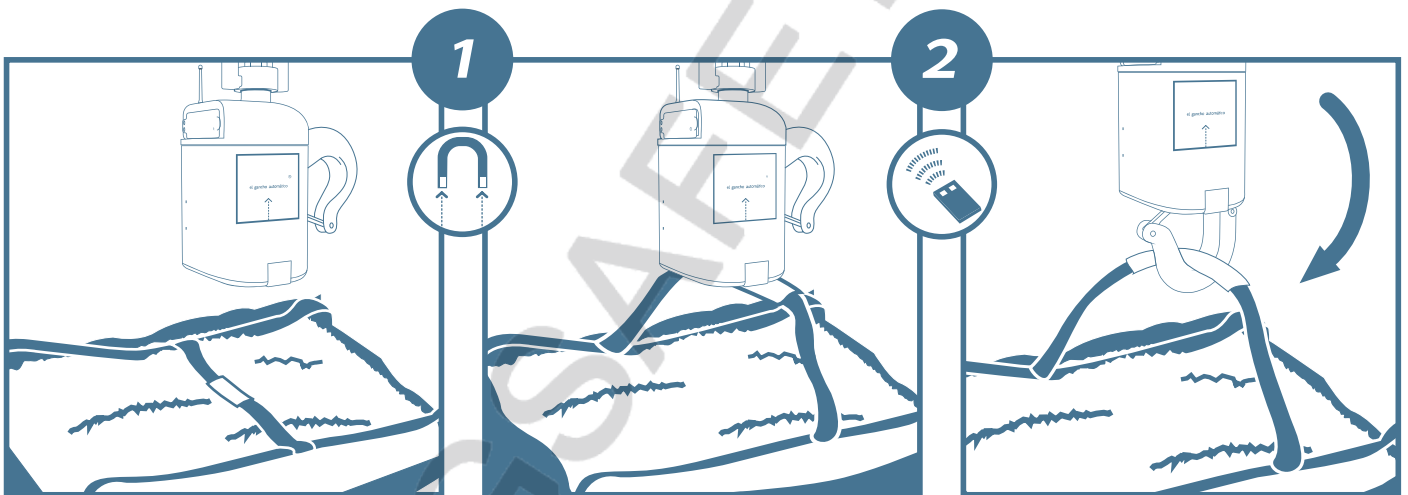

SELS presents the automatic remote control hook system that hooks and releases loads, and avoids handling and journeys. The patented system has a magnet at the bottom, which when brought close to the load, attracts and aligns the sling. The user presses a button on the remote control, the hook closes, catches hold of the sling and lifts the load, thus avoiding any handling at all. The system can operate with cable slings, chain slings, traditional lifting rings, textile slings\*, pallet lifters and even big bags.

*Disclaimer: this brochure is merely informative. The manufacturer reserves the right to modify specifications.*



# LIFTINGSAFETY

SELBY ENGINEERING AND LIFTING SAFETY LTD

Tel: +44 (0) 1977 684 600 Email: sales@liftingsafety.co.uk

**LIFTING EQUIPMENT AND HEIGHT SAFETY SPECIALISTS**

## Main features

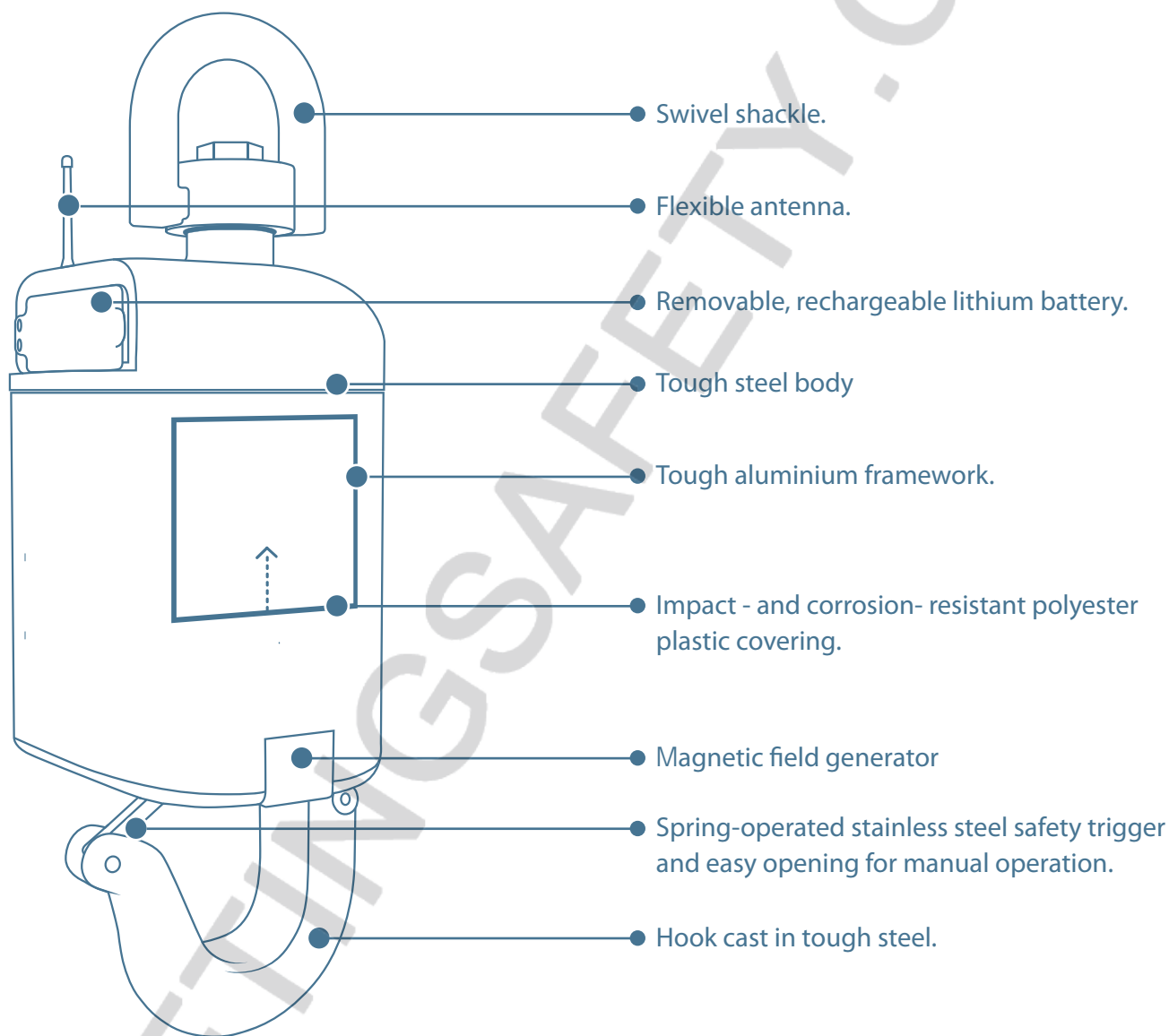

**WLL: 5tn**

**SF: 4:1**

**IP65**



# LIFTINGSAFETY

SELBY ENGINEERING AND LIFTING SAFETY LTD  
 Tel: +44 (0) 1977 684 600 Email: sales@liftingsafety.co.uk  
**LIFTING EQUIPMENT AND HEIGHT SAFETY SPECIALISTS**

## system specifications

Working Load Limit:	5t
Safety Factor:	4:1
Approximate weight:	35Kg
H, h, A, B (cm):	65,49,22,17
Working temp. range:	-20 to 40°C
Remote control:	included
Battery:	included
Battery charger:	included
Maximum releasable weight (*)	4 Kg
IP:	65
Explosive atmospheres:	not suitable

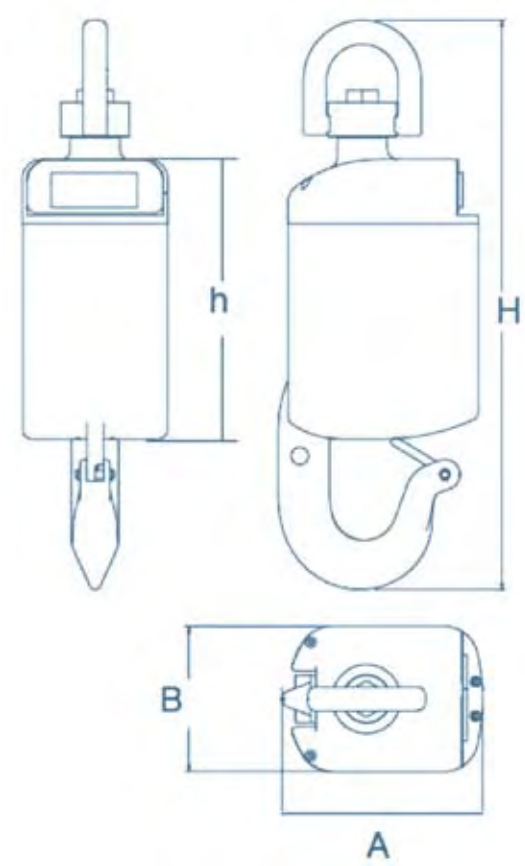

(\*) Designed to release sling elements with a weight of under 4 kg. Should an attempt be made to release heavier weights, the control electronics will interrupt the opening operation.



# LIFTINGSAFETY

SELBY ENGINEERING AND LIFTING SAFETY LTD  
Tel: +44 (0) 1977 684 600 Email: sales@liftingsafety.co.uk  
**LIFTING EQUIPMENT AND HEIGHT SAFETY SPECIALISTS**

## Installation of the system

Simply connect the battery and join to the crane (using a suitable element, will  $\geq 5$  fs  $\geq 4$ ). Optionally, a free crane control channel may be used if installed by qualified personnel (official elebia<sup>®</sup> workshop).

\* The battery should be fully charged (2.5 hours) before starting work.

**1. insert battery**

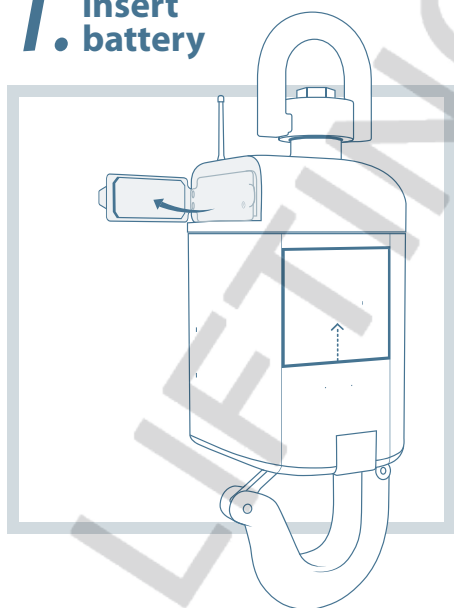

**2. connect battery**

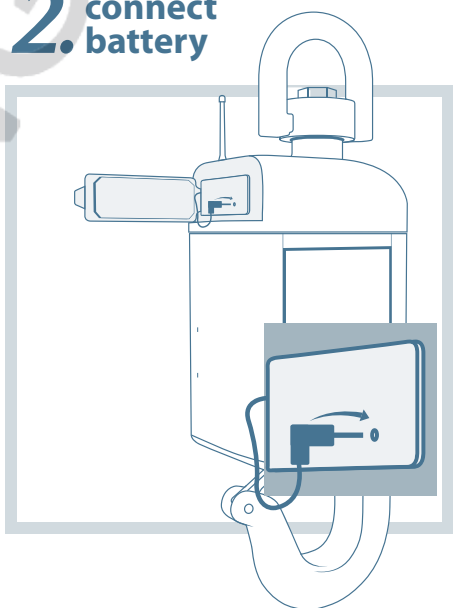

**3. hang**



*Disclaimer: this brochure is merely informative. The manufacturer reserves the right to modify specifications.*



# LIFTINGS SAFETY

SELBY ENGINEERING AND LIFTING SAFETY LTD  
 Tel: +44 (0) 1977 684 600 Email: sales@liftingsafety.co.uk  
**LIFTING EQUIPMENT AND HEIGHT SAFETY SPECIALISTS**

## remote control



868 MHz

Press and keep pressed for 5 seconds to change between "Fast" and "Safe" mode

- 0 to 9 – e5 battery level
- S – Safe mode
- F – Fast mode
- C – Check ( inspection / maintenance )

Open or close the hook (in "safe" mode, press the "mode" button first)

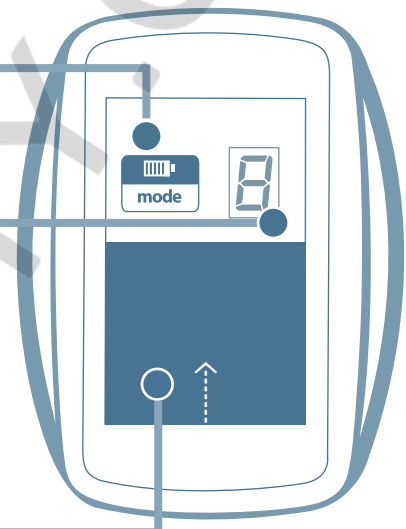

Power supply	1 3V lithium battery (CR2032)
Available Code Combinations	65,536 different combinations
Detection of Errors in Transmission	2 CRC bytes + Forward Error Correction
Buttons	2
Frequency selection	1
Frequencies	865.95 MHz / 869.85 MHz
Communication	Bi-directional return of receiver battery status
Certification standards	EN 300 220 Telecommunications EN 301 489 Electromagnetic Compatibility EN 60730 Low Voltage
Radiated power	under 5 dBm
Antenna	Printed circuit
Range	100 metres
Consumption at rest/transmission operation	5 uA/ 20 mA
Working temperature	-20 to +85°C
Dimensions	Minitel box (68 x 52 x 17 mm)

*Disclaimer: this brochure is merely informative. The manufacturer reserves the right to modify specifications.*



# LIFTINGSAFETY

SELBY ENGINEERING AND LIFTING SAFETY LTD

Tel: +44 (0) 1977 684 600 Email: sales@liftingsafety.co.uk

**LIFTING EQUIPMENT AND HEIGHT SAFETY SPECIALISTS**

## 24v cc Charger

### OPERATION

Plug in the corresponding connector to the vehicle's lighter socket (lighter connector) and connect the jack at the other end of the cable to the battery.

#### \* Recommendation:

Although battery charging cuts off when the charging process is complete, the adapter/charger should be disconnected once the process has finished (3 hours).

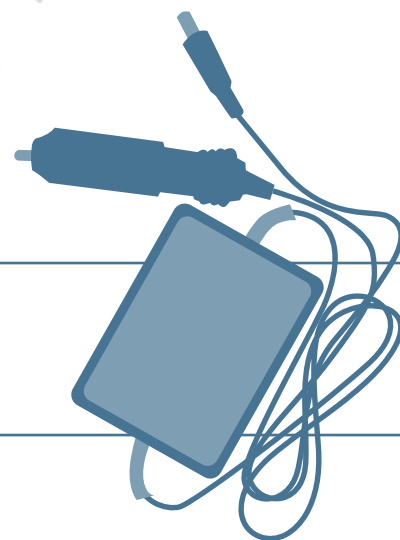

### IMPORTANT

This adapter/charger should be used only in vehicles with a 24-volt connector.

## 230v charger (accessory not included):

Charger specially designed for lithium ion and lithium polymer cells and packs.

### Specifications

### Technical specifications

Number of cells	6 Li-ion/Li-Polymer cells in series
Input voltage	100V - 240V 50Hz - 60Hz 0.15 max
Output voltage	25.2V
Output intensity	1A max.
Charge indicator	Yes, by red LED
Charge complete indicator	Yes, by green LED
Dimensions	52 x 33 x 75 mm
Weight	135 g
Recommendations	For interior use only Only recharge Li-ion/Li-Polymer packs

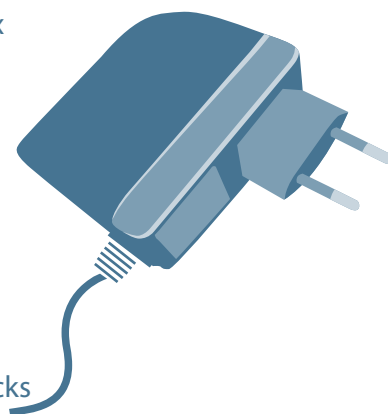

*Disclaimer: this brochure is merely informative. The manufacturer reserves the right to modify specifications.*



## Inspection and maintenance of the system

Proper maintenance of the system will lengthen its useful life and allow work to be done in safety. It is the user's responsibility to respect the 'Safety Recommendations' attached to this manual, to undertake the corresponding inspections, and to withdraw the mechanism in the event of deterioration or malfunction.

Frequent visual inspection to detect cracks and deformations, and inspection of crucial parts (hook opening) is recommended. In the event of cracks or deformations of over 1%, the mechanism must be withdrawn.

A minimum of one service should be performed each year. Every 10,000 cycles, the letter C for "check" will appear on the display. The official distributor should be visited for inspection and preventive maintenance work. The frequency of inspections may vary according to the intensity and type of use in each case.

Non-performance of checks and maintenance may lead to cancellation of the guarantee.

## Guarantee

The guarantee for products is for 2 years and covers parts and labour for the use envisaged and recommended in the system's manual of use. Batteries and maintenance operations, and the materials and labour involved therein, are exempt from guarantee.

## Safety recommendations

As the manufacturer has no direct control over the operation of the system, the safe handling of the equipment is therefore the responsibility of the user and of the operating personnel. This list of WHAT MUST and WHAT MUST NOT BE DONE is based on the ANSI/ASME B30.16 standard. Ask your supervisor for a copy. Each warning is identified in accordance with the ANSI/NEMAZ535.4 standard, either with the PRECAUTION or the WARNING sign, to indicate the degree of seriousness.

- ⚠ NOTE: the system features a powerful magnet. Do not approach with metal items. Magnetic cards, credit cards, hard disks and other magnetic elements may be damaged if brought close to the magnet.
- ⚠ NOTE: disconnect power sources prior to handling.



# LIFTINGSAFETY

SELBY ENGINEERING AND LIFTING SAFETY LTD  
Tel: +44 (0) 1977 684 600 Email: sales@liftingsafety.co.uk  
**LIFTING EQUIPMENT AND HEIGHT SAFETY SPECIALISTS**

## Warning:

Under no circumstance does the manufacturer either accept any liability for the use of these recommendations, which are voluntary, or guarantee them. The recommendations do not take precedence over standards and regulations.

## Breakdowns:

In the event of breakdown or malfunction, withdraw the mechanism and consult the technical service.

## Regulatory standards

- |  |                            |  |
|--|----------------------------|--|
| - Directive on machine safety (D89/37/EEC) | -D89/391/EEC               | - Assurance of production quality in accordance with ISO 9001                      |
| -UNE-EN 1050                               | -D89/654/EEC               | - Each mechanism is delivered with the CE stamp and a declaration of CE conformity |
| -UNE-EN ISO 12100-1                        | -D89/655/EEC               |  |
| -UNE-EN ISO 12100-2                        | -D89/656/EEC               |  |
| -UNE-EN 61000-6-4                          | -D92/58/EEC 9 <sup>a</sup> |  |
| -UNE-EN 61000-6-2                          | -UNE-EN 1677               |  |
|  | -EN 10204 3.1.B            |  |

*Disclaimer: this brochure is merely informative. The manufacturer reserves the right to modify specifications.*





## Precaution



Inappropriate use of the system may give rise to potentially dangerous situations and, if not prevented, these could lead to death or serious injury. To avoid such situations the operator must:

- 1 NOT operate the system if it is not working properly or if working unusually.
- 2 NOT operate the system before having completely read and understood the manufacturer's operation and maintenance instructions or manuals.
- 3 NOT operate the system if it has been altered without the manufacturer's approval.
- 4 NEITHER lift nor pull more than the load stipulated for the system.
- 5 NOT use the system if it is damaged, lacks components or is not working properly.
- 6 NOT use the system with twisted, tangled, damaged or worn load slings.
- 7 NOT use the system to lift, sustain or transport people.
- 8 NOT lift loads over people and ensure that people remain at a distance from the load.
- 9 NEITHER attempt to work with the equipment nor repair it if it is damaged.
- 10 NOT apply the load either to the tip of the hook or its safety mechanism.
- 11 NOT leave the weight sustained by the system unattended unless specific precautions have been taken.
- 12 NOT allow the use of the system to make electrical or earth contact for welding operations.
- 13 NOT attempt to open the hook when it is loaded. When the system sustains a load  $\geq 4$  kg, it will not open under any circumstances, even if the release order is given.
- 14 If the hook is opened when it is holding a load of under 4 kg, the system will open and release it, which may cause damage.



# LIFTING SAFETY

SELBY ENGINEERING AND LIFTING SAFETY LTD

Tel: +44 (0) 1977 684 600 Email: [sales@liftingsafety.co.uk](mailto:sales@liftingsafety.co.uk)

**LIFTING EQUIPMENT AND HEIGHT SAFETY SPECIALISTS**

- 15 Work with the remote control in "safe" mode when the hook is transporting sling or load elements < 4 kg. Risk of involuntarily release of the load is thus prevented.
- 16 NOT use the magnet to lift loads. Its sole function is to attract and align the sling or metal ring and thereafter place it inside the hook.
- 17 NOT allow the chain or the hook to be touched by a live welding electrode.
- 18 NEITHER withdraw NOR cover the warning signs of the system.
- 19 NOT operate the system if it has not been properly secured.
- 20 NOT lift loads unless the load slings or other accessories are of the correct size and suitably fastened to the hook.
- 21 NOT operate the mechanism if there are people touching it or very close to it.
- 22 NOT operate the system when it is not in a vertical position.
- 23 NOT lift loads that are neither balanced nor secured or if the load is not suitably fastened. Any slackness must be carefully tightened.
- 24 NOT operate the system unless all people are and remain outside the area of the sustained load.
- 25 Provide notification of any malfunction or abnormal performance of the system, after the system has been disconnected for repair.
- 26 NOT operate the system if it lacks the safety signs or transfers or if they are illegible.
- 27 Be familiar with the system's operation controls, procedures and warnings.



# LIFTINGSAFETY

SELBY ENGINEERING AND LIFTING SAFETY LTD

Tel: +44 (0) 1977 684 600 Email: [sales@liftingsafety.co.uk](mailto:sales@liftingsafety.co.uk)

**LIFTING EQUIPMENT AND HEIGHT SAFETY SPECIALISTS**

## Warnings

- 1 Keep a steady posture or secure yourself somehow when operating the system.
- 2 Use the hook's safety catch. The safety catches are to hold slings and chains, etc. only when slack.
- 3 Make sure that the hook's safety catch is closed and no load is sustained.
- 4 Make sure that the load is free to move and free of all obstacles.
- 5 Avoid swinging the load or the hook.
- 6 Inspect the system regularly, replace damaged or worn parts, and keep proper maintenance records.
- 7 Use the replacement parts recommended by the manufacturer when the unit is repaired.
- 8 DO NOT allow your attention to waver when handling the system.
- 9 DO NOT allow improper use of the system cause it to knock structures or objects.
- 10 DO NOT adjust or repair the system. This must be done by qualified personnel.
- 11 Ensure that the recommended maintenance routines are performed.



# LIFTINGSAFETY

SELBY ENGINEERING AND LIFTING SAFETY LTD

Tel: +44 (0) 1977 684 600 Email: sales@liftingsafety.co.uk

**LIFTING EQUIPMENT AND HEIGHT SAFETY SPECIALISTS**

## Conformity declaration and manufacturer's certificate

Identification Certificate: B60781168, and ISO 9001 certificate No. 9000041

### DECLARES:

Under its sole responsibility, that the following automatic hook system with a maximum operating load of 5 t, manufacturer's test load of 122.7 kN and a minimum attained breaking load of 196.2 kN, complies with the Directives 98/37/EC of the European Parliament and of the Council, of 22 June 1998, on the approximation of the laws of the Member States relating to machinery, and 2004/108/EC, on the approximation of the laws of the Member States relating to electromagnetic compatibility, and has been manufactured in accordance with the following harmonised standards:

EN-1677-1, EN-1677-2, EN-ISO12100-1, EN-ISO12100-2, EN-50081-2, EN-610006-2 and EN-60204-1: 1998.

Authorised signatory:

Place and date

*Disclaimer: this brochure is merely informative. The manufacturer reserves the right to modify specifications.*



# LIFTINGSAFETY

SELBY ENGINEERING AND LIFTING SAFETY LTD

Tel: +44 (0) 1977 684 600 Email: sales@liftingsafety.co.uk

**LIFTING EQUIPMENT AND HEIGHT SAFETY SPECIALISTS**

## Maintenance check

Date:  
Observations:

Date:  
Observations:

Date:  
Observations:

Date:  
Observations:

Date:  
Observations:

Date:  
Observations:

Date:  
Observations:

Date:  
Observations:



# LIFTINGSAFETY

SELBY ENGINEERING AND LIFTING SAFETY LTD  
Tel: +44 (0) 1977 684 600 Email: sales@liftingsafety.co.uk  
**LIFTING EQUIPMENT AND HEIGHT SAFETY SPECIALISTS**

## Guarantee

Distributor:

Date:

*Disclaimer: this brochure is merely informative. The manufacturer reserves the right to modify specifications.*