



TECHNICAL SHEET

TRALIFT TE
Electric Chain Hoist
 for 1/8 to 2 ton capacities

R-1234

Date: 04.23.03

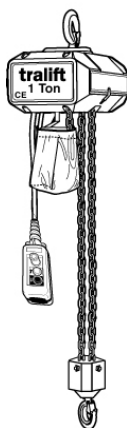

Model	Rated Load ton (lbs)	Number of Chain Falls	Load Chain Size ϕ x pitch, mm	Lifting Speed ft/min. (m/min)	Lifting Motor Power hp	Hoist Weight w/10ft (3m) of lift lbs. (kg)
TE 125	1/8 (250)	1	4 x 12	39 (12) 39/12 (12/3.6)	0.4 0.4/0.13	55 (25)
TE 250	1/4 (500)	1	5 x 15	33 (10) 33/10 (10/3.2)	0.55 0.55/0.17	68 (31)
TE 500	1/2 (1000)	2	5 x 15	16 (5) 16/5 (5/1.6)	0.55 0.55/0.17	73 (33)
TE 500	1/2 (1000)	1	6.3 x 19	33 (10) 33/10 (10/3.2)	1.2 1.2/0.17	84 (38)
TE 1000	1 (2000)	2	6.3 x 19	16 (5) 16/5 (5/1.6)	1.2 1.2/0.17	95 (43)
TE 1000	1 (2000)	1	8 x 24	23 (7) 23/7 (7/2.3)	2.1 2.1/0.75	124 (56)
TE 2000	2 (4000)	2	8 x 24	13 (4) 13/3 (4/1)	2.1 2.1/0.75	141 (64)

Specifications:

- Classified as H4 ASME Hoist Duty Class
- Powered by 3 phase 230v or 460v (fully convertible) w/ phase protector
- Enclosure rating - hoist IP54 pendant IP65 (NEMA3)
- Fully adjustable cam style upper and lower electrical limit switches
- Available in one or two falls versions.
- A rigid suspension hook or lug.
- A cast aluminum frame made of bolted modular parts.
- A motor mounted in the hoist frame and fitted with thermal protection.
- grade 80 case hardened load chain
- swiveling load hook mounted on ball bearings
- A double gear train gearbox sub-assembly with with a friction clutch load limiting device.
- A separate asbestos-free electromagnetic brake.
- Low voltage electrical (48V).pendant control with emergency stop button.
- stiched nylon chain bag.
- Temperature range 14° to 104°F (-10° to +40°C)

Standards and Requirements in compliance:

- Applicable sections of the "ANSI/ASME B30.16 "Overhead hoists" and ASME HST-IM standard.
- The National Electrical Code (ANSI/NFPA 70)
- The Occupational Safety and Health Act (OSHA) 29 CFR1910, 1926
- ANSI Z244.1 Safety Requirements for the lockout/ tag out of energy sources
- ANSI/ASME B30.9 Slings
- ANSI/ASME B30.20 Below-the-Hook lifting devices
- ANSI/ASME B30.10 Hooks
- ANSI Z241.2 Safety Requirements for Melting and Pouring of Metals in the Metalcasting Industry
- References for CSA codes Canadian Electrical Standards
- CE Certified

Dimensional Information:

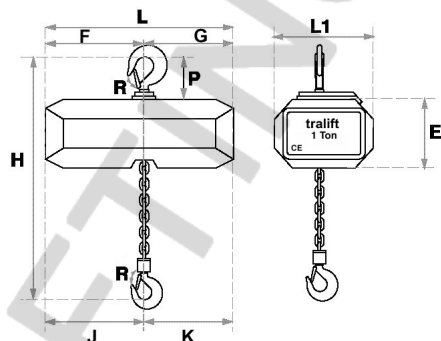

Model	Number of Chain Falls	L	L1	E	F	G	H	J	K	P	R
TE125	1	19.3	7.9	6.9	11.8	7.5	13	11.8	7.5	3	0.9
TE250	1	20	8.7	7.5	12.2	7.9	13.4	12.2	7.9	3	0.9
TE500	2	20	8.7	7.5	12.2	7.9	16.9	12.2	7.9	3.3	0.9
TE500	1	20.9	9	7.9	13	7.9	15.7	13	7.9	3.6	0.9
TE1000	2	20.9	9	7.9	13	7.9	18.9	13	7.9	4.1	1.2
TE1000	1	23	11.4	7.3	13.8	9.3	19.3	13.8	9.3	4.1	1.2
TE2000	2	23	11.4	7.3	13.8	9.3	22.8	13.8	9.3	4.3	1.5



NOTE:
 Dimensions in inches.



Tractel Grip Hoist Div.
 110 Shawmut Rd.
 Canton, MA 02021
 Tel: (781) 401-3288
 Fax: (781) 828-3642

APRIL 2003