

RANGE OF BEAM CLAMPS



• Beam clamps for manual and electric hoists

- WLL 1 tonne to 10 tonnes
- Range of 5 models
- Compact and sturdy construction
- Simple and fast adjustment on "I" profile
- Removable handle

- In accordance with:
 - Machinery Directive 98/37/CEE
 - European standard EN 292 (Safety equipment).

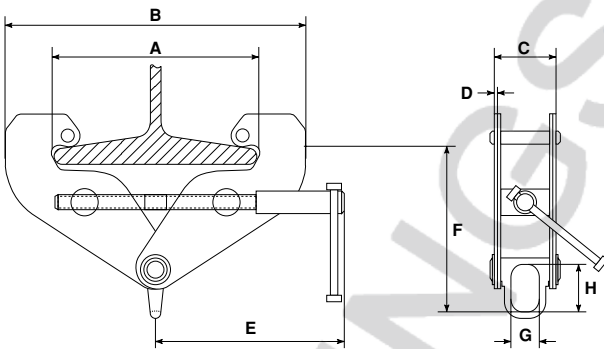
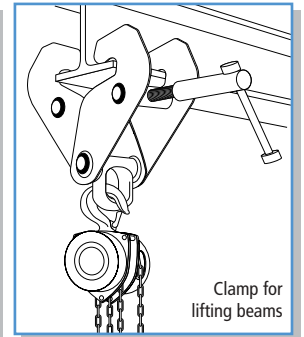
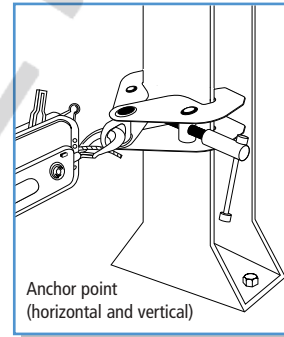

Model	WLL	Dimensions								Recommended "I" rail (width)* (mm)	Weight (kg)		
		A max. (mm)	B min. (mm)	B max. (mm)	C (mm)	D (mm)	E (mm)	F min. (mm)	F max. (mm)			G (mm)	H (mm)
LT-1B	1000 kg	270	180	380	76	4	210	120	175	30	45	75 à 235	4,8
LT-2B	2000 kg	270	182	380	84	6	210	130	180	30	40	75 à 240	5,6
LT-3B	3000 kg	360	235	490	115	8	275	175	250	45	60	95 à 335	11
LT-5B	5000 kg	354	253	490	138	10	245	140	220	45	60	95 à 330	12,3
LT-10B	10 000 kg	320	255	480	160	12	275	250	300	60	90	90 à 300	21

* - Figures for guidance only; possible variance ± 5 mm



www.tractel.com - E-mail : info@tractel.com

tralift®

manual chain hoists with accessories

UK



- HIGH QUALITY
- LIGHTWEIGHT
- RELIABLE
- LOW MAINTENANCE



RANGE OF MANUAL CHAIN HOISTS

Complete range:

- WLL 0.250 to 20 tonnes
- Hooks with 360° swivel
- Automatic brake with double pawl system
- Tested to 150% of WLL
- Self-lubricating chain, corrosion resistant, made to standard NFE 26-010 (resists marine mists >800 h. and temperatures to 280° C.)
- Optional load limiter

In accordance with: **CE**
 - Machinery Directive 98/37/CEE
 - European standard EN 292 (Safety equipment).

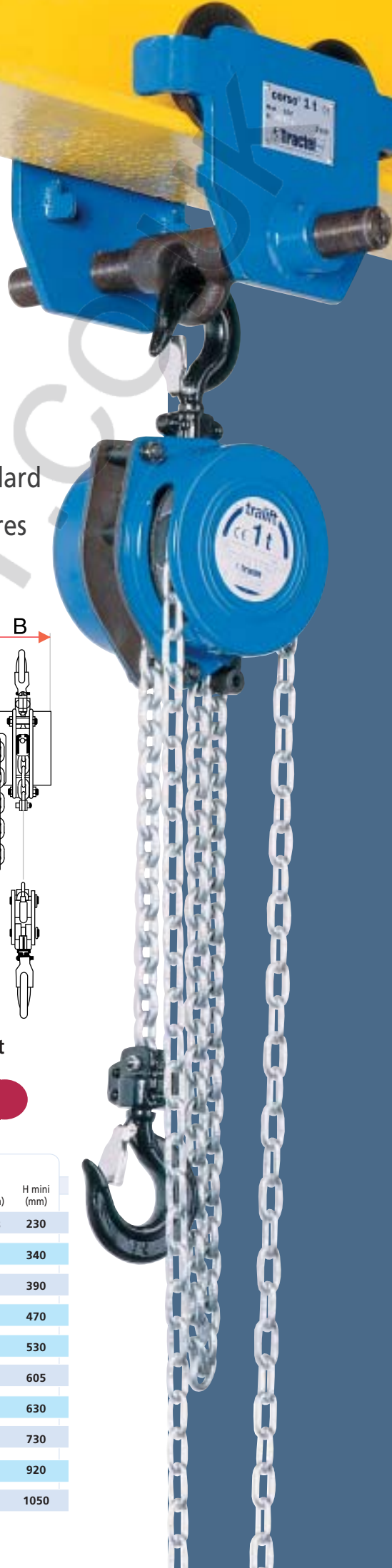
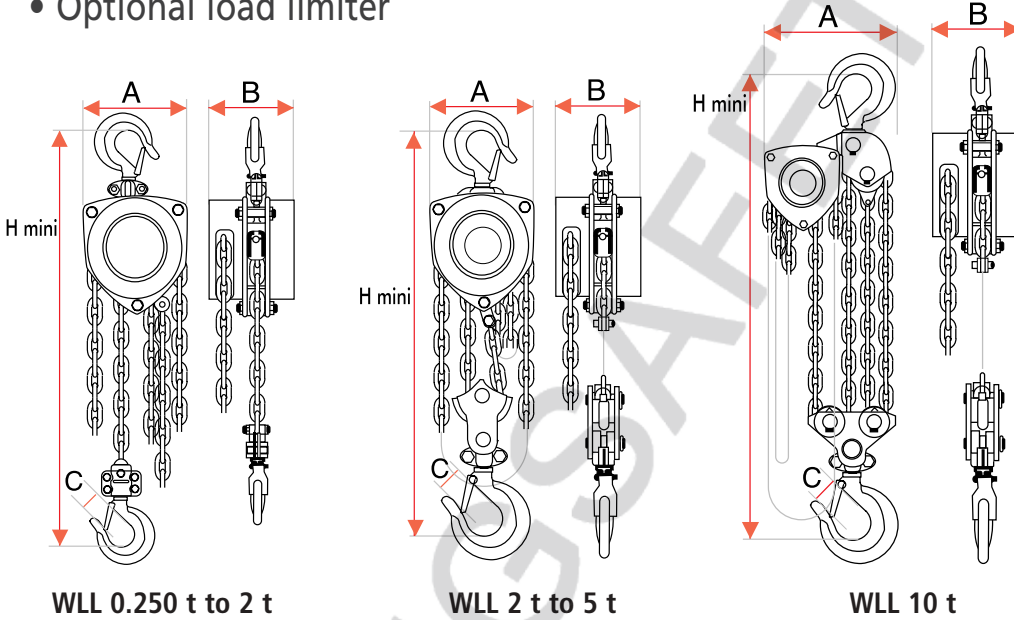

GENERAL SPECIFICATION

Model	WLL	Number of falls	Effort on hand chain (daN / kg)	Load chain (mm)	Hand chain (mm)	Hoist weight 3 m lift (kg)	Chain weight** (kg)	Dimensions			
								A (mm)	B (mm)	C (mm)	H mini (mm)
250	250 kg	1	11	4 x 12	5 x 24	4	0,54	100	110	18	230
500	500 kg	1	21	5 x 15	5 x 24	9	1,5	132	112	23	340
1000	1000 kg	1	34	6 x 18	5 x 24	12	1,7	156	134	27	390
1500	1500 kg	1	38	8 x 24	5 x 24	19	2,3	196	150	31	470
2000	2000 kg	2	36	6 x 18	5 x 24	18	2,5	156	134	35	530
2000	2000 kg	1	40	8 x 24	5 x 24	20	2,3	229	155	35	605
3000	3000 kg	2	42	8 x 24	5 x 24	28	3,7	196	150	39	630
5000	5000 kg	2	45	10 x 30	5 x 24	41	5,3	229	171	45	730
10 000	10.000 kg	4	47	10 x 30	5 x 24	79	9,7	395	171	57	920
20 000*	20.000 kg	8	50	10 x 30	5 x 24	178	19,4	642	200	75	1050

* - Model on request
 ** - Weight of load chain and hand chain per meter.

RANGE OF TRAVELLING TROLLEYS



Chain operated trolley



Push trolley



10 t push trolley

Range of travelling trolleys: WLL 0.5 to 5 tonnes.

- over-dimensioned flanges
- wide adjustment range
- steel rollers mounted on bearings
- double threaded traverse bar with closed suspension eye
- blocking of traverse bar, after adjustment by BTR screw
- steel end stops shaped to serve as anti-derail bars
- anti-tipping devices soldered onto flanges
- very low lost headroom
- quick and easy assembly and adjustment with the handle (supplied as standard)

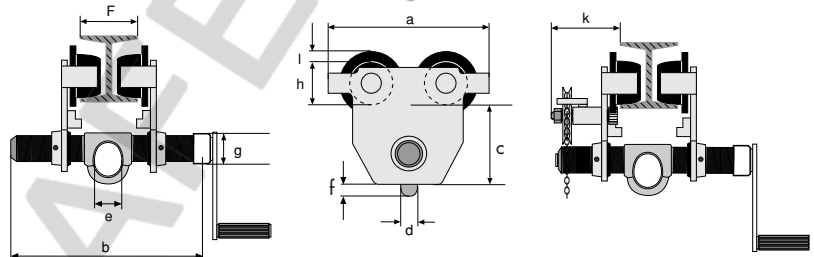

10 t and 20 t models ** :

- Rollers with bearings
- Adjustment facility when in position
- Anti-drop device and safety screw
- 20 t model: only available as chain operated

• In accordance with: **CE**
 - Machinery Directive 98/37/CEE.
 - European standard EN 292 (Safety equipment).

GENERAL SPECIFICATION

Model	WLL	Dimensions										F traverse bar 1 (mm)	F traverse bar 2 (mm)	Min. radial curve (mm)	Theoretical effort on chain (N)	Weight of push trolley (kg)	Weight of chain operated trolley (kg)
		a (mm)	b*** (mm)	c (mm)	d (mm)	e (mm)	f (mm)	g (mm)	h (mm)	i (mm)	k (mm)						
500	500 kg	225	324	88	16	25	16	27	62	15	*	50 - 220	220 - 300	900	*	8,5	-
1000	1000 kg	252	334	103	17	30	17	30	62	15	100	58 - 220	220 - 300	1000	55	10,5	19
2000	2000 kg	300	342	127	21	40	18	38	80	18	120	66 - 220	220 - 300	1200	100	18	22,5
3000	3000 kg	360	358	177	21	48	18	45	97	15	135	74 - 220	220 - 300	1300	75	32	37,5
5000	5000 kg	400	372	192	31	58	23	52	110	20	145	90 - 220	220 - 300	1400	120	48,5	55

* Model only available as push trolley
 ** For 10 t and 20 t models, please ask for dimensions data
 *** Traverse bar 1