

**1. GENERAL**

The BLOCSTOP is a fall-arrest secondary safety device which, when fitted to an appropriate TIRFOR/TIRAK wire rope, can be used in conjunction with almost any lifting equipment

The BLOCSTOP is particularly well suited as a safety device on suspended cradles and platforms. It may also be used to hold or restrain any other loads during lifting and pulling applications.

The BLOCSTOP may be used:

- a) Mounted on a **separate safety wire rope** (Fig. 1) if required by safety regulations for suspended scaffolding and platforms in particular countries (e.g. Denmark, France, Sweden, Switzerland). The BLOCSTOP holds the load safely should there be any defect in the suspension wire rope or malfunction of the lifting machine.
- b) Mounted on the **suspension or tensioned wire rope**, the BLOCSTOP protects the load against malfunction of the lifting/tensioning device.

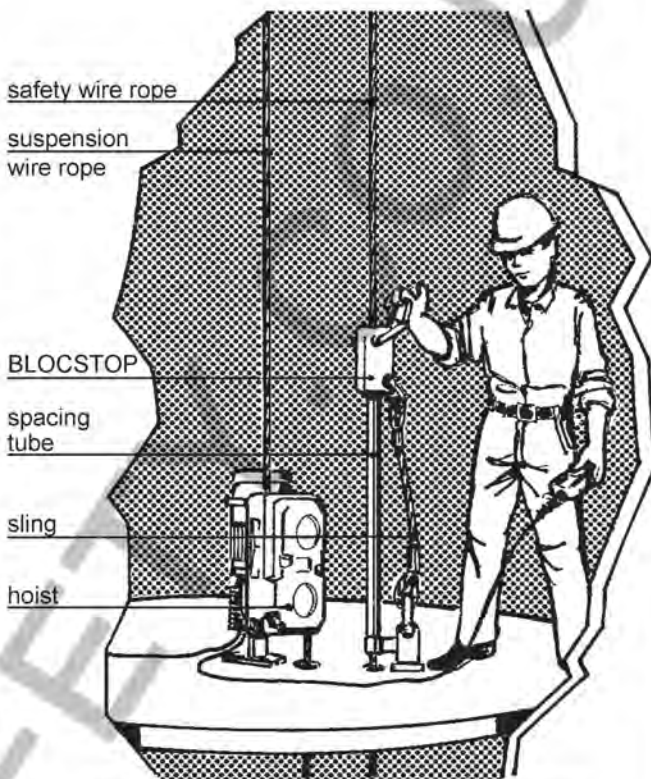
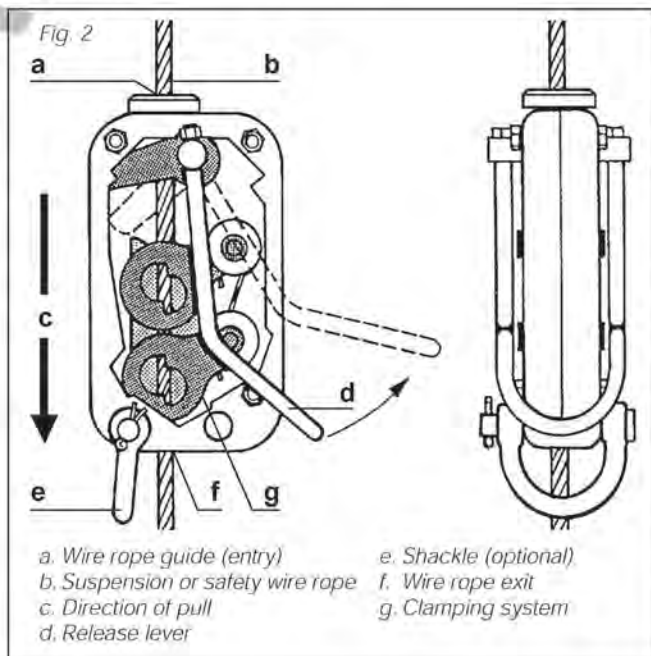

Fig. 1 - Safety suspension assembly of a platform in chimney construction

**2. THE BLOCSTOP PRINCIPLE**

A set of jaws (Fig. 2), used successfully in all TIRFOR machines over many years, serves as the gripping device. The system is the self-locking type, i.e. if the wire rope is pulled against the direction of pull, the jaws automatically clamp onto the wire rope. The greater the pull, the more the jaws grip the wire rope.

The self gripping jaw system of the BLOCSTOP is designed not to damage the wire rope, even when used in EMERGENCY situations.



**3. THE BLOCSTOP MODELS**

**3.1. BLOCSTOP BS models**

**3.1.1. Hand operated BLOCSTOP**

While **lifting a load or tensioning a wire rope** the rope passes through the BLOCSTOP. There is no need to operate the BLOCSTOP.

For **lowering the load or releasing the wire rope** the BLOCSTOP is opened by lifting the operating lever upwards (Fig. 6).

In case of a malfunction of the **hoist or a defect in the suspension wire rope** (if the BLOCSTOP is mounted on a separate safety wire rope) releasing the operating lever, or pulling the lever downwards, caused by panic reaction, ensures that the load is instantly and safely held.

Once the BLOCSTOP has taken the load (e.g. when the operating lever is released) it cannot be opened again, so strong is its grip on the wire rope. First lift the load a little to take the load off the BLOCSTOP, then you can release it again to continue lowering.

**Mounting the BLOCSTOP** is very easy. If the lifting machine is operating with TIRFOR or TIRAK wire rope, the BLOCSTOP is mounted on the wire rope above the hoist (Fig. 4).

If using other wire rope, or if safety regulations require a secondary safety wire rope, fit the BLOCSTOP to this secondary wire rope (Fig. 5).

In both cases the BLOCSTOP is connected either to the load or to an anchor point with a sling or other suitable attachment. Ensure that the BLOCSTOP is able to align itself in the pulling direction.

To avoid dynamic shocks the BLOCSTOP should not be allowed to move more than 5 cm (when attached to a sling). Use a spacing device in order to keep the sling in tension when lifting.

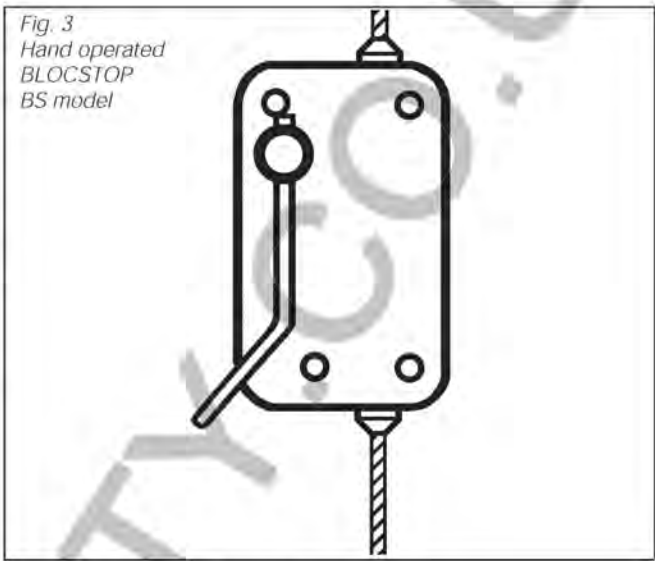

**BLOCSTOP modèles BS**

model	code	nom. cap. kg	weight kg	for TIRFOR/TIRAK wire rope	
				diam. mm	type
BS 15.311	3259	500	2.0	6.5	A6
BS 15.301	3219	800	2.0	8.3	C8
BS 20.300	15929	800	3.7	8.3	C8
BS 20.303	3239	1000	3.7	9.5	A9
BS 20.330	6029	1000	3.7	10.2	A10
BS 20.301	3129	1600	3.7	11.5	C12
BS 35.30	3149	3200	8.7	16.3	C16

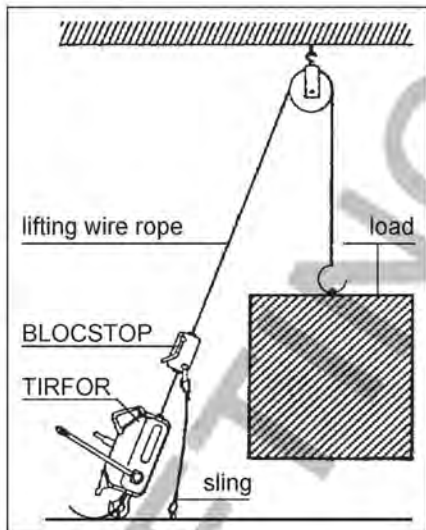

Fig. 4 - BLOCSTOP on lifting wire rope

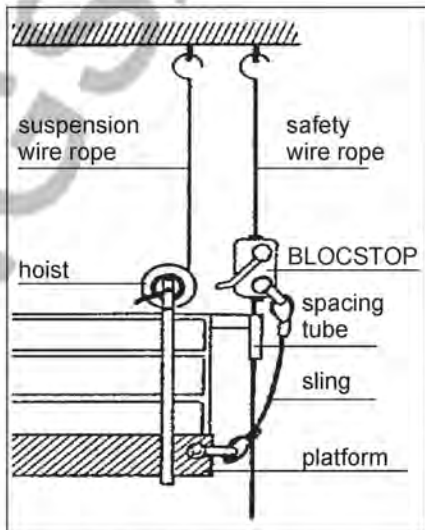

Fig. 5 - BLOCSTOP on safety wire rope

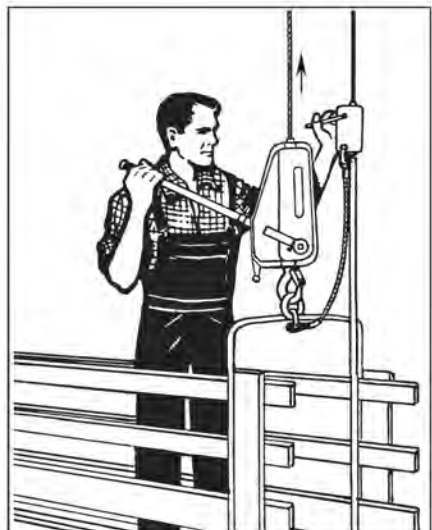

Fig. 6 - Releasing the BLOCSTOP whilst lowering the platform

**3.1.2. BLOCSTOP BS**  
**weight dependent automatic slack wire rope device**

When used on a permanent application (e.g. on our ALTA platforms) a **fixed mounting** is recommended. The automatic operation of the BLOCSTOP is as follows:  
The hoist is not rigidly fixed to the cradle. It initially slides upwards a short distance in a guiding device before lifting the load. The effect of this movement (1) is to raise the release lever (2) of the rigidly fixed BLOCSTOP (Fig. 7).  
In case of failure of the suspension wire rope the hoist drops (this movement is accentuated by an incorporated pressure spring), and the BLOCSTOP locks onto the wire rope and immediately holds the cradle.

**3.2. BLOCSTOP BSA**  
**automatic slack wire rope device**

This type can only be used on a secondary safety wire rope in parallel with a main suspension wire rope. The BLOCSTOP is rigidly mounted and operated by the tensioned suspension wire rope (Fig. 8). This system not only protects against suspension wire rope failure or hoist malfunction but also against excessive slope of the cradle.  
If the cradle gets into a sloped position, (e.g. caused by the non-operation of one hoist) and reaches a point where the suspension wire rope is too far away from the BLOCSTOP to hold the release lever in the open position (Fig. 9.1), the BLOCSTOP at the lower end of the cradle locks onto the safety wire rope to prevent further lowering.  
When the cradle has been brought back into the horizontal position, and the loading on the BLOCSTOP has been removed by lifting the cradle for a short distance, descent may then be continued.  
**CAUTION** - To guarantee a suitable operation of this automatic safety system, the distance between the upper suspension points has to be 100 mm.

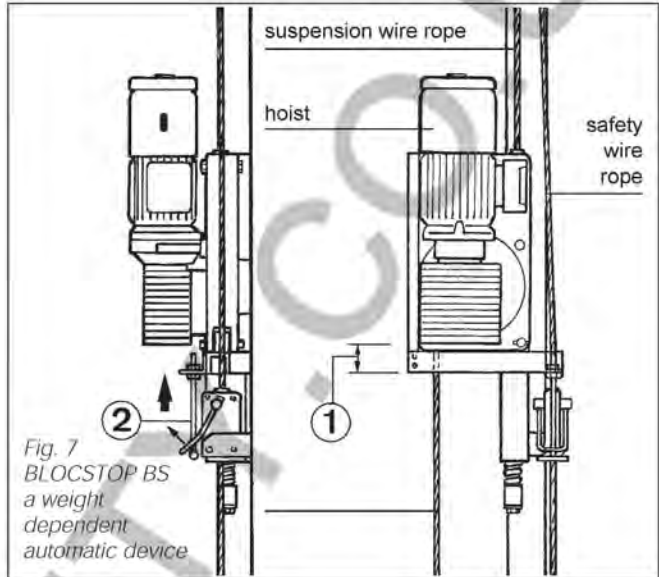

Fig. 7  
BLOCSTOP BS  
a weight  
dependent  
automatic  
device

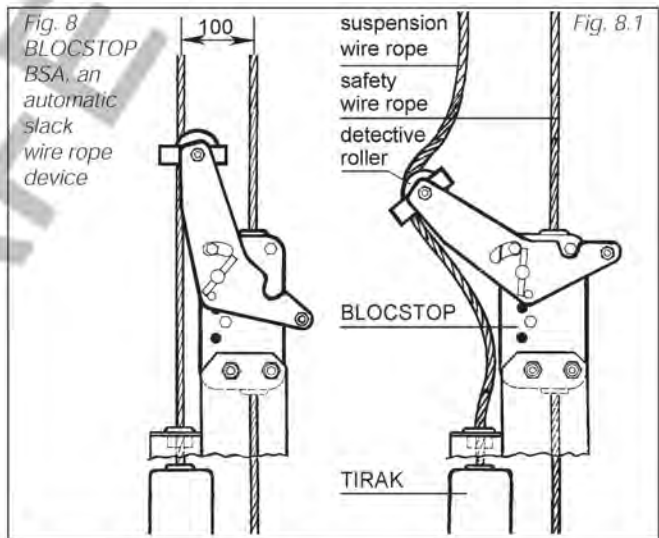

Fig. 8  
BLOCSTOP  
BSA, an  
automatic  
slack  
wire rope  
device

Fig. 8.1

model	code	nom. cap. kg	weight kg	for TIRFOR/TIRAK wire rope	
				diam. mm	type
BSA 15.301	3279	800	4.0	8.3	A8 / C8
BSA 15.303	6019	800	4.0	9.5	A9 / C9
BSA 20.300	15939	800	6.0	8.3	A8 / C8
BSA 20.303	15949	1000	6.0	9.5	A9
BSA 20.330	6039	1000	6.0	10.2	A10
BSA 20.301	15049	1600	6.0	11.5	C12
BSA 35.30	17999	3200	9.7	16.3	C16

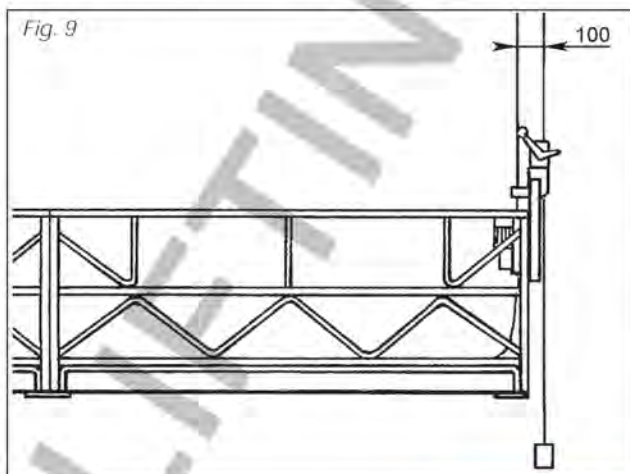

Fig. 9

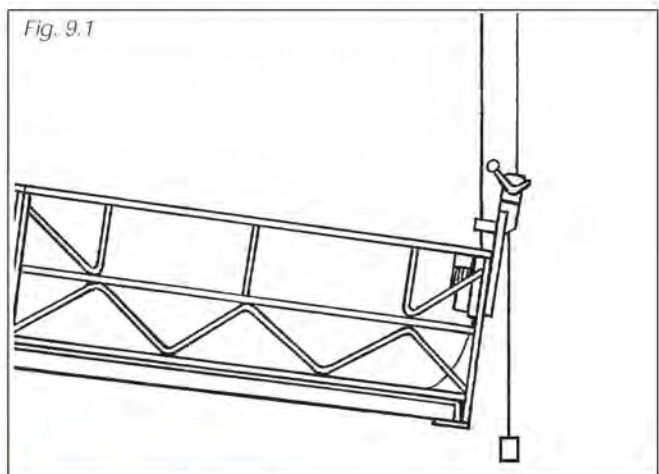

Fig. 9.1

**3.1. Dimensions – BLOCSTOP BSA series**

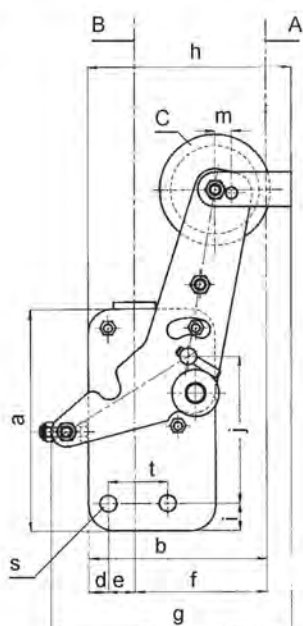

Fig. 10 - BSA 15 serie

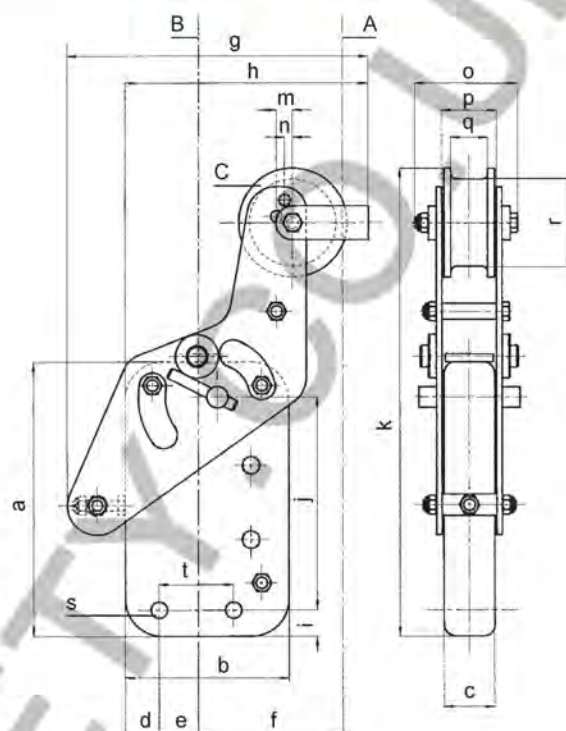
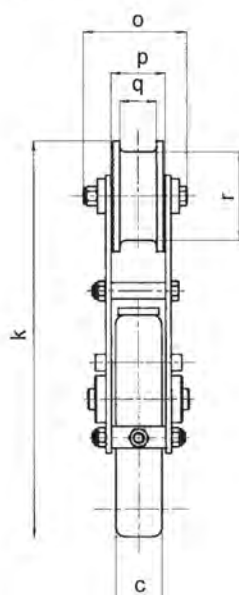

Fig. 11 - BSA 20 serie

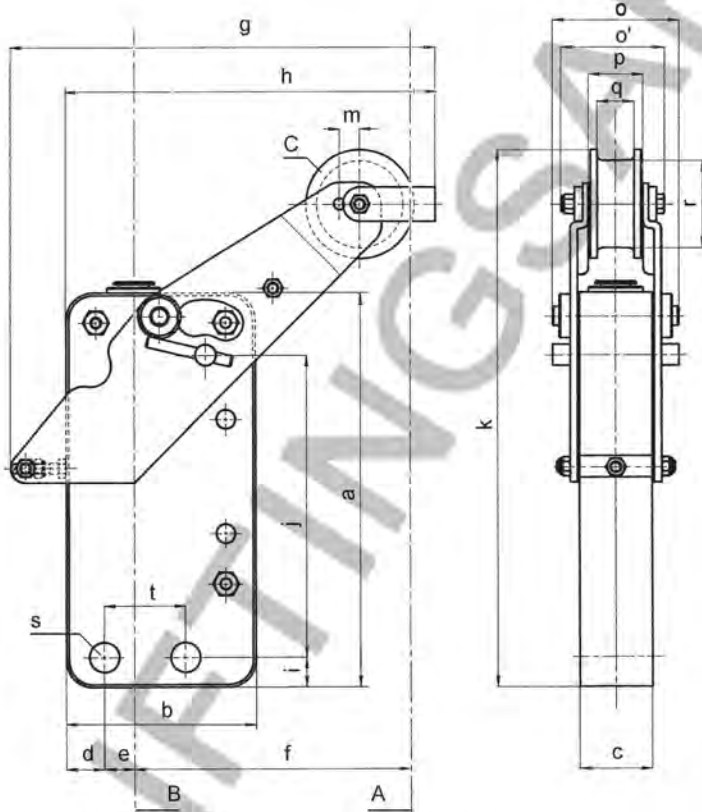

Fig. 12 - BSA 35 serie

dimensions (mm) – serie

	BSA 15	BSA 20	BSA 35
a	161	203	290
b	91	121	140
c	34	37	53
d	14	25	28
e	19	29	22
f*	95/107	95/101/107	189/204
g	173	222	313
h	146	179	270
i	20	19,5	22
j	106.5	157.5	222
k	287	345	395
m	12	12	15
n	-	6	-
o	75	75	90
o'	-	-	75
p	40	40	40
q	27	27	27
Ør	64	64	64
Øs	12.1	12.1	22
t	42.5	55	60

\* according to the position of the detective roller (C)

- A. Lifting wire rope
- B. Safety wire rope
- C. Detective roller