

<b>technical sheet</b>	<b>Motorised TIRFOR with hydraulic power pack</b>	réf. :	<b>T2008</b>
		rév. n° :	
		date :	<b>09/95</b>
		page :	<b>1/3</b>

A motorised TIRFOR TU-16H (1600 kg) or TU-32H (3200 kg) system is made up of 1, 2 or 4 TIRFOR machines (1) fitted with self-reciprocating hydraulic rams (2), and a hydraulic power pack (3) with an electric motor or petrol engine, together with one or more sets of hydraulic hoses (4) and one or more wire ropes (1.1) of the appropriate length (standard: 20 m). The power pack operates a pump which gives a flow of 13 litres of hydraulic fluid per minute, passing through the control valve and then to the ram(s).

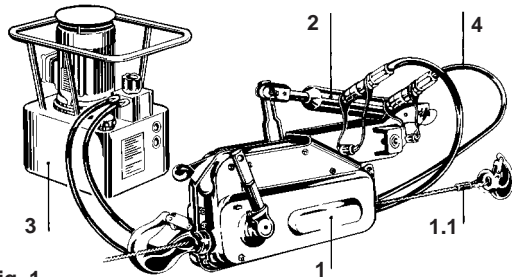

Fig. 1

### 1. TIRFOR machines

Hydraulic TIRFOR TU-16H and TU-32H machines (Fig. 2 and 3) are developed from the standard TU-16H and TU-32H machines. The self-reciprocating hydraulic ram is mounted on the anchor bracket (19) which is fitted to the casing.

The nominal pulling power is constant whatever the system used. The speed of operation (i.e. the speed of wire rope passing through the machine) is however a function of the number of machines which are fed from the same power pack. Also, the speed can be controlled through the flow control valve (24).

#### 1.1. Special TIRFOR wire rope

For correct operation of TIRFOR machines, only use the special TIRFOR wire rope; its design and specification are especially suited to the correct operation of the machine.

	TU-16H	TU-32H
Diameter (mm)	11.5	16.3
Breaking strain (kg)	9600	19000
Standard length (m)	20	20
(other lengths available on request)		

### 2. Self-reciprocating hydraulic ram

The hydraulic ram (V A2 for TU-16H and V A3 for TU-32H) incorporates a self-reciprocating system which gives power in both directions. A safety valve avoids any overload of the ram.

	TU-16H	TU-32H
Weight with ram (kg)	29	52
Dimens. (mm)	788x150x360	1070x210x430

TU-16H	1 x 1600 kg	2 x 1600 kg	4 x 1600 kg
TU-32H	1 x 3200 kg	2 x 3200 kg	4 x 3200 kg

The capacity is for a single line lift.

It is possible to increase capacity by using multiple sheave blocks.

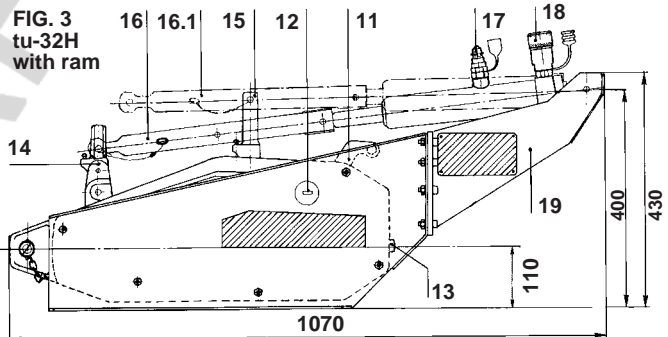
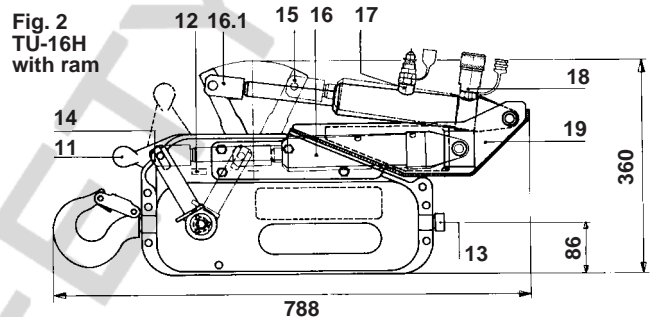

- |                             |                                    |
|-----------------------------|------------------------------------|
| 11. Rope release lever      | 16. Hydraulic ram in forward O.P.  |
| 12. Rope release catch      | 16.1 Hydraulic ram in reverse O.P. |
| 13. Rope guide              | 17. Pressure hose (male connector) |
| 14. Forward operating lever | 18. return hose (female connector) |
| 15. Reverse operating lever | 19. Ram anchor bracket             |

#### 2.1. Specification of the ram

	VA2	VA3
Working stroke	mm	134 172
Cylinder volume per complete cycle (double stroke)	cm <sup>3</sup>	129 162
Cycles per minute (no load, 13 l/mn. flow)		78
Wire rope movement per complete to and fro stroke, with nominal capacity:		
forward operation	(mm)	37 14
reverse operation	(mm)	44 25

### 3. Hydraulic power pack

The hydraulic power pack supplies the power to operate the TIRFOR machine(s) (TU-16H or TU-32H). It consists of an electric motor or petrol engine with a pump, oil reservoir and a control valve. Pump flow: 13 l/mn.

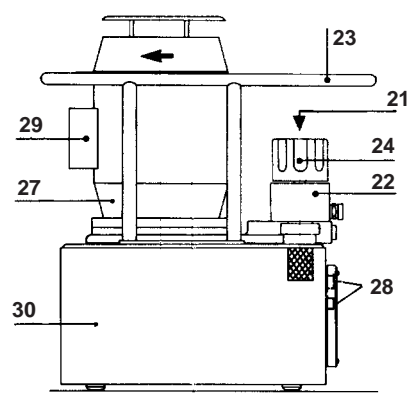

Fig. 4 : Electric motor

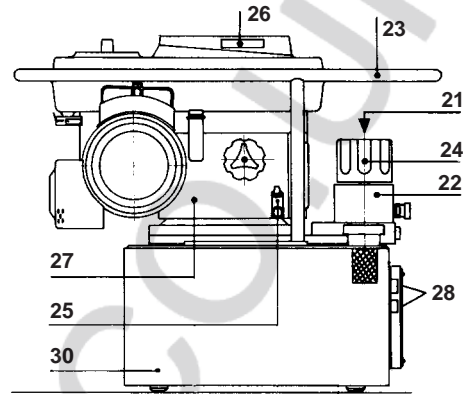
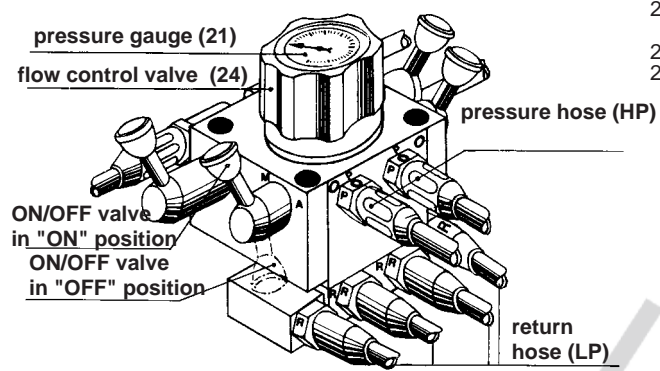

Fig. 5 : Petrol engine

Fig. 6 : Bloc de commande



- 21. Pressure gauge
- 22. Control valve
- 23. Shock resistant carrying frame
- 24. Flow control valve
- 25. Engine oil gauge (petrol engine)
- 26. Starter for petrol engine
- 27. Electric motor or petrol engine
- 28. Oil level indicator
- 29. Switch for electric motor
- 30. Reservoir for hydraulic fluid

### 3.2. Technical specification of the hydraulic power packs.

Dimension (L x W x H) with electric motor	mm	490 x 400 x 580
with petrol engine	mm	620 x 400 x 510
Weight (with oil) electric motor	kg	53
Weight (with oil) petrol engine	kg	51
Reservoir capacity	l	17
Oil flow	l/mn	13
Electric motor	kW	3
220/380 V, 3000 RPM		
Petrol engine, 3000 RPM	kW	3.7

### 3.1. Control valve (Fig. 6)

The function of the control valve is to provide the correct flow of hydraulic fluid to each ram irrespective of the load on that ram. The overall speed of operation is controlled by the flow control valve, whilst the ON/OFF valves allow the individual control of each ram (control valves BC-2d and BC-4d).

A safety valve avoids any overload of the hydraulic system.

3 control valves are available:

- **Valve BC-S:** a single one way control valve with one outlet of 8 l/mn. to supply one ram only.
- **Valve BC-2d:** a two-way control valve with two outlets each receiving a flow of 6.5 l/mn. This control valve can also be used with a single ram by connecting the hose to the auxiliary outlet (S). In this case the ram receives the full flow of the pump (13 l/mn.).
- **Valve BC-4d:** a four-way control valve to feed 4 rams, each receiving a quarter of the pump flow (3.25 l/mn.).

**Note: it is important to specify the control valve required: BC-S, BC-2d or BC-4d.**

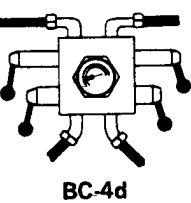
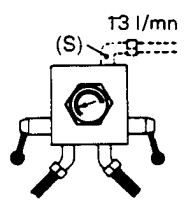
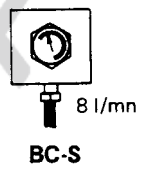

### 3.3 Speed of operation

		Flow			
		8 l/mn		13 l/mn	
		lifting	lowering	lifting	lowering
P. pack with... TU-16H	1	2	2.65	-	-
	2	-	-	1.50	2
	4	-	-	0.75	1
P. pack with... TU-32H	1	-	-	1	1.80
	2	-	-	0.50	0.90
	4	-	-	0.25	0.45

### 3.4. Operation with an existing hydraulic units.

It is sometimes convenient to operate a motorised TIRFOR from an existing hydraulic supply (on a lorry or tractor, etc.).

The following are the technical requirements for the efficient operation of the unit:

- pressure: 120-140 bars (TU-16H); 90-100 bars (TU-32H)
- flow : 13 l/mn.
- hydraulic oil: 2° to 5°; engler viscosity at 50° C.
- viscosity index: over 100
- filter: 40 microns

**4. Hydraulic hoses**

Each ram is connected to the control valve of the power pack by two hoses, one "pressure" (HP) and the other "return" (LP). A combination of quick-release male and female end-fittings ensure correct assembly. The hoses are available with an internal diameter of 10 mm in standard lengths of 3, 6 and 10 m. For longer lengths, available on request, it is recommended to use hoses with an internal diameter of 13 mm (NW13).

**4.1. Standard equipment**

- 1698 Set of hoses NW10 (pressure and return) length 3 m\*
- 1868 Set of hoses NW10 (pressure and return) 6 m\*
- 4518 Set of hoses NW10 (pressure and return) 10 m\*

**4.2. Recommended optional equipment\*\***

- 4838 Set of hoses NW10 (pressure and return), length 0,40 m\*
- 6158 SET of extension hoses (pressure and return) 3m\*

**4.3. Additional parts**

- 1938 1 hose NW10 (pressure or return),  
with nozzles for couplings length 3 m
- 1948 as above 6 m
- 1968 as above 10 m
- 11827 Quick release coupling (male & female) for NW10
- 11837 Quick release coupling (male & female) for NW10  
(TU-16H or TU-32H)
- 8106 Dust cap for male coupling
- 8116 Dust cap for female coupling

\* complete with quick-release couplings and dust caps  
 \*\* to make easier transport of power packs with more than one way and with hoses longer than 3 m.

**4.4. Maximum lengths (per way) of hydraulic hoses, 10 mm diameter (NW10)**

	TU-16H	TU-32H
1 way (flow 8 l/mn)	14 m	10 m
2 way (flow 13 l/mn)	16 m	10 m
4 way (flow 13 l/mn)	25 m	15 m

For hoses with 13 mm diameter (NW13), please contact us for advice.

