

# **CRANE OPERATING AND MAINTENANCE** **INSTRUCTIONS**

## **COUNTERBALANCE TYPE WORKSHOP** **TROLLEY CRANES**

**152-508 MODELS DRY SAND OR CONCRETE BLOCKS  
MAY BE USED AS A SUITABLE BALLAST**

**750, 1000 AND 2000 ONLY METAL WEIGHTS  
SHOULD BE USED DUE TO THE SIZE OF THE BALLAST  
CONTAINER**



**WEIGHT OF COUNTERWEIGHT REQUIRED FOR MAXIMUM CAPACITY'S**

<b>MODEL NO.</b>	<b>WEIGHT REQUIRED</b>
152	200 Kg
254	249 Kg
508	322 Kg
750	675 Kg
1000	900 Kg
2000	1032 Kg

# **ALWAYS READ THE INSTRUCTIONS BEFORE** **USING THIS EQUIPMENT**

**Ensure the correct amount of ballast is used before counterbalance crane/equipment is put into service or any load is lifted.**

**ALWAYS use a Mobile Crane/Lifting Equipment on a firm level surface.**

**NEVER use a Mobile Crane/Lifting Equipment on a sloping surface due to the danger of the Mobile Crane/Lifting Equipment moving or the load not being lifted correctly, i.e. off-centre loads could cause structural damage to the equipment and possible injury to Operator.**

**ALWAYS apply the brakes (when fitted) before commencing lifting operation.**

**NEVER lift off centre loads.**

**ALWAYS use the correct lifting tackle and use Lifting Hook/Hooks as directed on the enclosed instructions. ALWAYS use certified lifting aids.**

**NEVER move a crane with a high suspended load. Cranes with a suspended load should only be moved with the suspended load just clear of the floor. Move the crane slowly and avoid sudden crane stops which could cause the load to swing violently.**

**NEVER use the full length of the Hydraulic Ram this could cause damage to the Hydraulic Unit and make the load unstable.**

**Any modification to the Equipment or Hydraulic Pump/Ram will make this declaration of conformity invalid.**

**NEVER continue to exhaust the Safety Valve as this could cause the load to become unstable and damage the Safety Release Valve.**

**Hydraulic Oil should be changed ever 12 months. NEVER mixed different brands of Hydraulic Oil or use different viscosity.**

**A suspended load should only be lowered slowly and in a controlled manner.**

**ALWAYS move Equipment/Crane with the handle attached to the Equipment/Crane. NEVER use the Hydraulic Pump handle to move or position Equipment/Crane.**

**NEVER leave a suspended load for long periods. Lower loads onto a Supporting Frame.**

**NEVER allow any person to stand in such a position that the load could fall on them or cause a person injury.**

**ONLY adjust the Telescopic Jib with the main Support Jib in the horizontal position. This is to ensure that the Telescopic Jib will not inadvertently slide out. NEVER adjust the Telescopic Jib with a load attached.**

**DO NOT use the Equipment/Crane if any defect is observed, report to a competent person.**

**ENSURE that all Spring Clips are in place.**

**NEVER EXCEED THE SAFE WORKING LOAD OF THE EQUIPMENT/CRANE.  
THE MAXIMUM LOAD ONLY APPLIES WHEN THE INNER JIB IS FULLY RETRACTED  
(I.E. POSITION 1)**

# **IMPORTANT**

**Date: 16-6-99**

## **WORK EQUIPMENT**

Virtually the whole of the UK industry was affected when the provision and use of Work Equipment Regulations 1998 (PUWER 98)(LOWLER 98) came into force on the 5 December 1998.

The two sets of regulations- which implemented the requirements of the European Commissions Amending Directive to use of Work Equipment Directive (AUWED) apply to the majority of workplaces in the UK and include several new provisions relating to safety of work equipment. PUWER 98- which replaced the existing PUWER 1992 and the Power Press Regulations 1965 and 1972-included new provisions for management and the use of MOBILE Work Equipment and also introduced new regulations specific to power presses.

Under PUWER 98, the definition of work equipment include the following: \* Lifting Equipment-such as hoists, lift trucks, elevating work platforms and lifting slings including floor cranes and installations. PUWER 98 completely replace the requirements of PUWER 1992, which was originally implemented into UK law as part of the six-pack, of health and safety legislation.

## **THE MAIN REQUIREMENTS**

While the requirements of PUWER 1992 were carried forward in full, in parts 1 and 11 of PUWER 98, the new regulations also contained a number of important additions.

These included: a requirement to inspect work equipment where significant risk could result from incorrect use/installation or relocation, deterioration, or as a result of exceptional circumstances.

A requirement to record the results of those inspections.

An extension of the duty holder application to include a duty on people who have control of work equipment, such as plant hire companies.

New guidance and ACoP material on the control of specific risks.

Meanwhile, part 111 of PUWER 98 comprised of six completely new regulations which deal with risks arising from mobile work equipment including lift trucks, floor cranes ect.

These include, minimising risks from roll-over, preventing start-up by unauthorised persons, providing a device for braking,

## **LIFTING EQUIPMENT**

LOLER 98 replace most of the existing sector-specific legislation on lifting equipment, creating a single set of regulations that apply to all sectors of industry.

LOLER 98 applies over and above the general requirements of PUWER 98 in dealing with specific hazards and risks associated with lifting equipment and lifting operations.

## **WARNING**

The regulations require employers to carry out a risk assessment of lifting operations- including the selection-suitability of equipment and the use of lifting equipment.

Continued

The regulations require employers to carry out suitable training of staff in the safe use of the lifting equipment, including operating and safety maintenance-inspection.

Employers need to consider a number of factors when selecting lifting equipment, these include- the load to be lifted-its weight, shape and centre of gravity and the availability of lifting points.

How often the lifting equipment will be used to carry out the task. The environment in which the lifting equipment is being used, the personnel available and their training and experience.

The regulations also require lifting equipment to have adequate strength and stability for its proposed use.

In addition, the risk from positioning and installing lifting equipment need to be minimised and equipment must be marked to indicate its safe working load.

The regulations also require certain types of lifting equipment for example, hooks, eye-bolts and shackles-to be examined every six months.

Any other lifting equipment must be examined every 12 months.

However under the regulations an alternative examination scheme can be drawn up and intervals set for examinations based on the results of risk assessments.

In addition, the regulations cover pre-use checks and the steps that employers must take to prevent lifting equipment overturning or being overloaded.

They also cover how lifting equipment should be positioned and installed and the use of equipment to lift people-for example, a lift truck must include a purpose-built working platform to carry an employee.

## **FINAL CHECKLIST**

Under health and safety law, employers have a legal duty to ensure the health, safety and welfare of employees and people not in their employment who may be affected by their work activities.

The six-pack of health and safety legislation-which came into force in January 1993-includes the management of Health and Safety at Work Regulations 1992, this requires all employers to carry out a risk assessment in the workplaces to eliminate or reduce any risks found.

The Lifting Equipment and Lifting Operations Regulations 1998 (LOLER 98) require lifting equipment to have adequate strength and stability for its proposed use. In addition, the risks from positioning and installing lifting equipment need to be minimised and equipment must also be marked to indicate its safe working load.

## **IMPORTANT**

Under Health and Safety Law, Employers and Self Employed Personnel have a legal duty to ensure the Safe Working Conditions for all employees and personnel that may come into contact with the equipment, E-G. Workshop Presses, moving and Fixed Cranes, Scissor Lift Trolleys and all types of equipment that could or may present a potential danger to an employee or persons present in the vicinity, must carry out a specific risk and hazard assessment of all equipment in the workplace to eliminate or reduce any risk found, and to record and update the results of this inspection, and to keep records at all times.

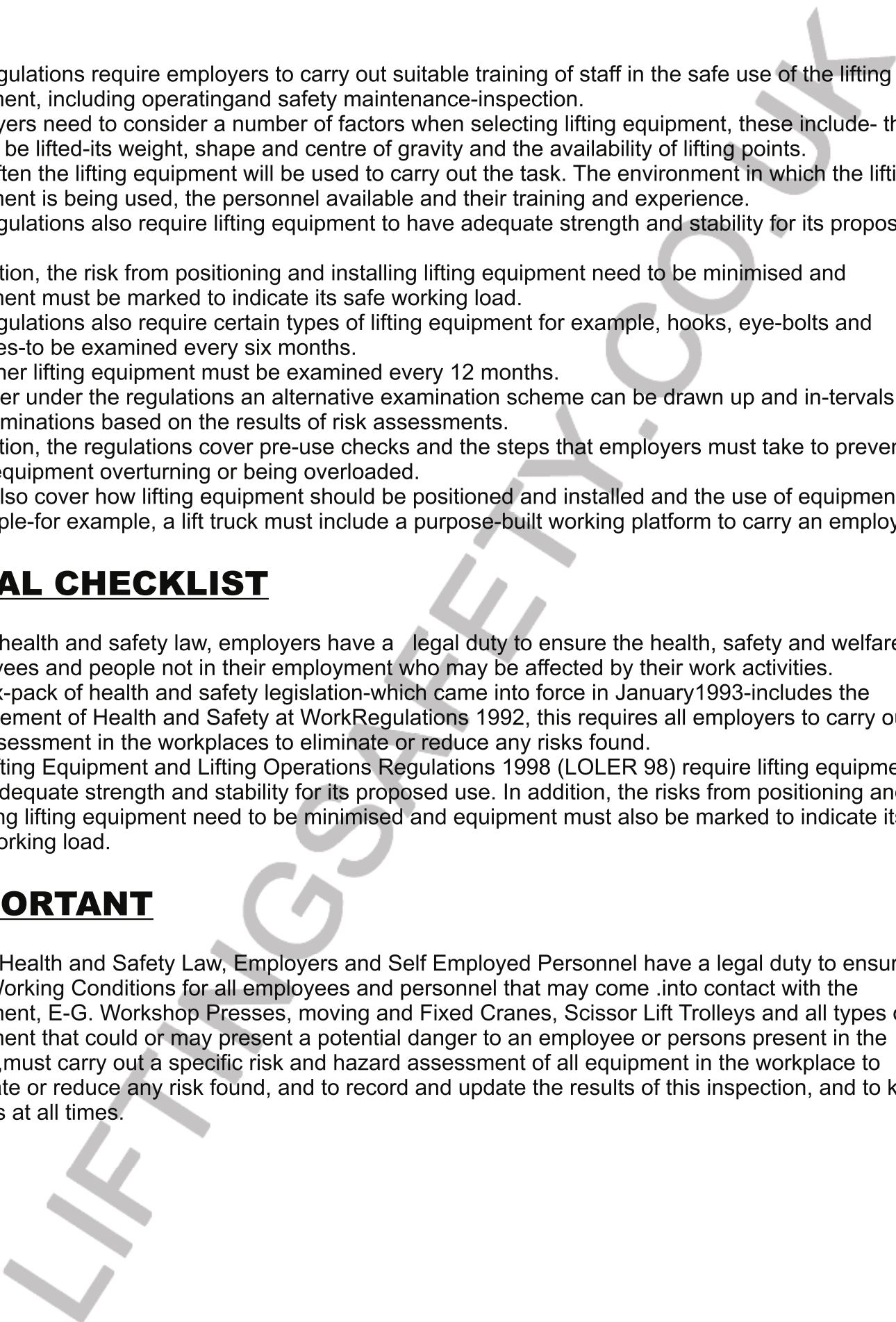

# INSTRUCTIONS FOR THE SAFE WORKING

Manufactured to a high standard, this product will, if used in accordance with the instruction, and is properly maintained give years of trouble free service.

## **IMPORTANT**

**BEFORE USING THIS PRODUCT, PLEASE READ THE INSTRUCTION CAREFULLY. MAKE CAREFUL NOTE OF SAFETY INSTRUCTIONS, WARNINGS AND CAUTIONS. THIS PRODUCT SHOULD ONLY BE USED FOR ITS INTENDED PURPOSE. FAILURE TO DO SO MAY CAUSE DAMAGE OR PERSONAL INJURY, AND WILL INVALIDATE THE WARRANTY.**

The use of symbols and adhesive labels in this document and attached to the product is to attract your attention to possible DANGER and REMINDERS, the symbols labels and warnings, themselves do not ELIMINATE the DANGER, nor are they a substitute for proper accident prevention measures.

## **SAFETY INSTRUCTIONS**

- 1) Familiarise yourself with this products application, as well as the limitations and specific potential hazards.
- 2) Ensure that the product is stable and suitable for the application.
- 3) The floor must be stable and solid so that the equipment will not cause injury during use.
- 4) Take special care to avoid trapping hands or feet.
- 5) Use only genuine spare parts, non-recommended parts may be dangerous.
- 6) Check regularly for damaged parts, broken or damaged parts should be replaced immediately.
- 7) Ensure the space required for use and maintenance of the equipment is adequate, and with good lighting.
- 8) Keep unauthorised persons and children away from the working area at all times.
- 9) Maintain the equipment in top condition at all times.
- 10) **Do not** use the equipment for anything other than its intended purpose.
- 11) **Do not** exceed the maximum safe working capacity of the equipment.
- 12) **Do not** modify or alter this equipment in any way.
- 13) **Do not** allow children or untrained persons to operate this equipment
- 14) **Do not** wear loose or ill-fitting clothing, ties, watches, rings, and any other jewellery, tie up or cover long Hair.
- 15) **Do not** stand on the equipment.
- 16) **Do not** use this equipment whilst under the influence of drugs, alcohol or any other intoxicating medication.
- 17) **Do not** use this equipment if you are fatigued.

# **IMPORTANT**

On receipt of your Crane if you carry out the following simple instructions the unit will give you many years of trouble free service.

1. Assemble machine as described.
2. Loosen Oil Filler Cap situated at the top of the Oil Reservoir. Do not add oil as unit is pre-filled on dispatch from the factory.
3. Fully open Release Valve and pump 11-12 times with a steady pumping action. Still pumping, close Release Valve. Do not over tighten as this may damage valve seat. Ram will now start to extend; carry on pumping till ram has extended 5 to 6 inches.  
Stop pumping and open Release Valve, pull on Crane Jib to return ram to fully closed position. Crane is now ready for use.  
Do not pump ram before releasing Oil Filler Cap or opening Release Valve.
4. To fold Crane for storage or transportation close Oil Filler Cap. Do not over tighten.
5. After storage or transportation be sure the above instructions are carried out before pumping the Ram Unit.

# **IMPORTANT**

IF THE OIL CHANGE IS COMPLETED EACH YEAR, OIL TOP UP SHOULD NOT BE REQUIRED.

SHOULD A LEAK OR OIL LOSS OCCUR, REMOVE THE PUMP FROM THE HYDRAULIC OIL RESERVOIR.

CHECK THAT THE OIL IS FREE FROM MOISTURE, FOREIGN BODIES, AND HAS NOT BEEN CONTAMINATED IN ANY WAY.

IF TOP UP IS REQUIRED USE ONLY TOTAL AZOLLA ZS 32 HYDRAULIC OIL.

DO NOT MIX BLENDS, DIFFERENT BRANDS OR VISCOSITY HYDRAULIC OILS.

# **WARNING**

**DO NOT ADD HYDRAULIC OIL  
FACTORY FILLED  
READ INSTRUCTIONS**

## Customer Supplied Ballast Weights

### WARNING

The correct amount of counterweight for the model specified below must be placed in that position. Failure to carry out this procedure correctly could result in having insufficient counterweight and will cause the crane to become unstable and could cause serious injury or even death.

### MINIMUM WEIGHT REQUIRED FOR COUNTERBALANCE CRANES

When sand, concrete, metal blocks or similar heavy material is used as counterweight. The weight required for each model is listed below.

<u>Model No.</u>	<u>Counterweight Required</u>
152	200 Kg
254	249 Kg
508	320 Kg
750	675 Kg This model will require metal ballast weights only
1000	900 Kg This model will require metal ballast weights only
2000	900 Kg This model will require metal ballast weights only

or material is used as counterweight.

On counterbalance cranes, Model No. 750, 1000 and 2000. Only metal weights can be used as counterweight, because of the ballast box size.

***ON NO ACCOUNT MUST SAND / CONCRETE BLOCKS OR SIMILAR MATERIAL BE USED AS COUNTERWEIGHTS ON THE 750, 1000 and 2000 ONLY USE METAL BALLAST***

The ballast can be spread over the entire area of the ballast box, however the ballast is more efficient if positioned to the rear of the ballast box, please ensure that the ballast is secure and not likely to move during operation and movement of the crane.

## Factory Supplied Ballast Weights

When metal weights are **factory** supplied, positioned and fitted to each counterbalance crane, the counterweight required for each model is listed below.

<u>Model No.</u>	<u>Counterweight Required</u>
152	100 Kg <i>This Amount of counterweight must only be used when factory fitted.</i>
254	147 Kg
508	308 Kg
750	462 Kg
1000	660 Kg
2000	660 Kg

On no account must any of the factory supplied metal weights be removed or repositioned in or around the crane's ballast weight box.

If an order for metal counterweights is not received with the crane and/or supplied at a later date, the counterweights must be positioned and fixed at the rear of the counterweight ballast box.

Weights are 100 x 50 flat mild steel they are drilled and tapped for easy fitting and removing, the ballast box is also fitted with a retaining frame to locate the ballast to the rear of the chassis, if any other ballast or a third parties metal weight are used please refer to 'customer supplied ballast weights'.

## Factory Supplied Ballast Weights Continued.

### WARNING

The amount of counterweight listed as factory fitted must only be used when ballast is supplied by the manufacturing company.

On No Account Must This Amount Of Weight Be Used When Counterweights Are Supplied By Any Other Source.

Position "C" Gives The Maximum Position Datum Line For Factory Supplied Metal Counterweights For All Models.

weights are 100 x 50 Flat Mild Steel they are drilled and tapped for easy fitting & removing the ballast box is also fitted with a retaining frame to locate the ballast to the rear of the chassis, if any other ballast or a third parties metal weight are used please refer to Customer Supplied Ballast Weights.

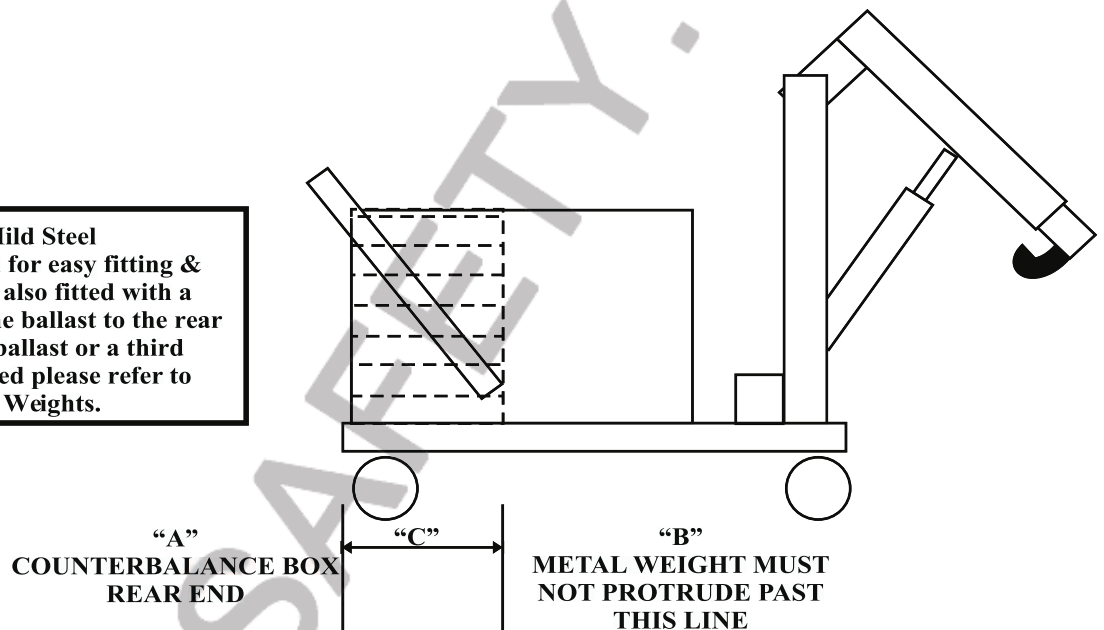

Model.	Counter Weight.	Weight Qty	Distance From Ballast Box Rear Panel
152	100 Kg	5 x 100 x 50 x 500mm	115 mm <i>DIMENSION "C"</i>
254	147 Kg	7 x 100 x 50 x 21"	115 mm <i>COUNTERWEIGHT</i>
508	308 Kg	14 x 100 x 50 x 23"	215 mm <i>MUST NOT</i>
750	462 Kg	21 x 100 x 50 x 23"	310 mm <i>PROTRUDE INTO</i>
1000	660 Kg	30 x 100 x 50 x 23"	310 mm <i>SECTION "B"</i>
2000	600 Kg	30 x 100 x 50 x 23"	420 mm

### Hydraulic Oil Requirements

The correct quantity of hydraulic oil required for each model.

Model	Pints	Litres
152	1.5	1
254	1.5	1
508	3	2
750	4	2.5
1000	4	2.5
2000	5	3

### NOTE

Do Not Add Hydraulic Oil, When Receiving Your Crane As The Hydraulic System Leaves The Factory Filled To The Correct Level.

# PARTS LIST FOR COUNTER BALANCE TROLLEY CRANES

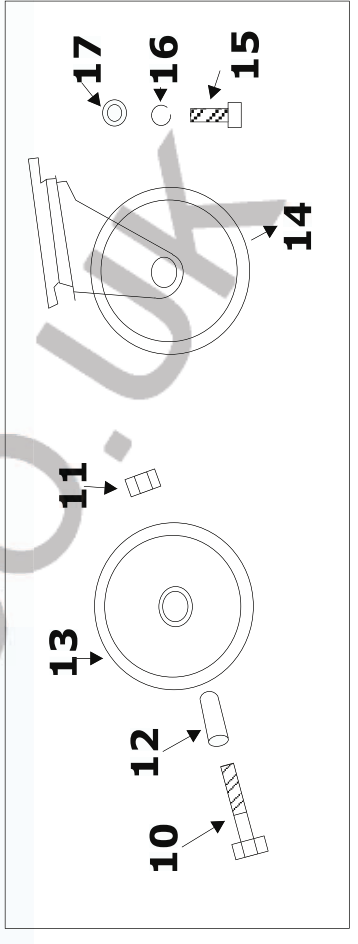
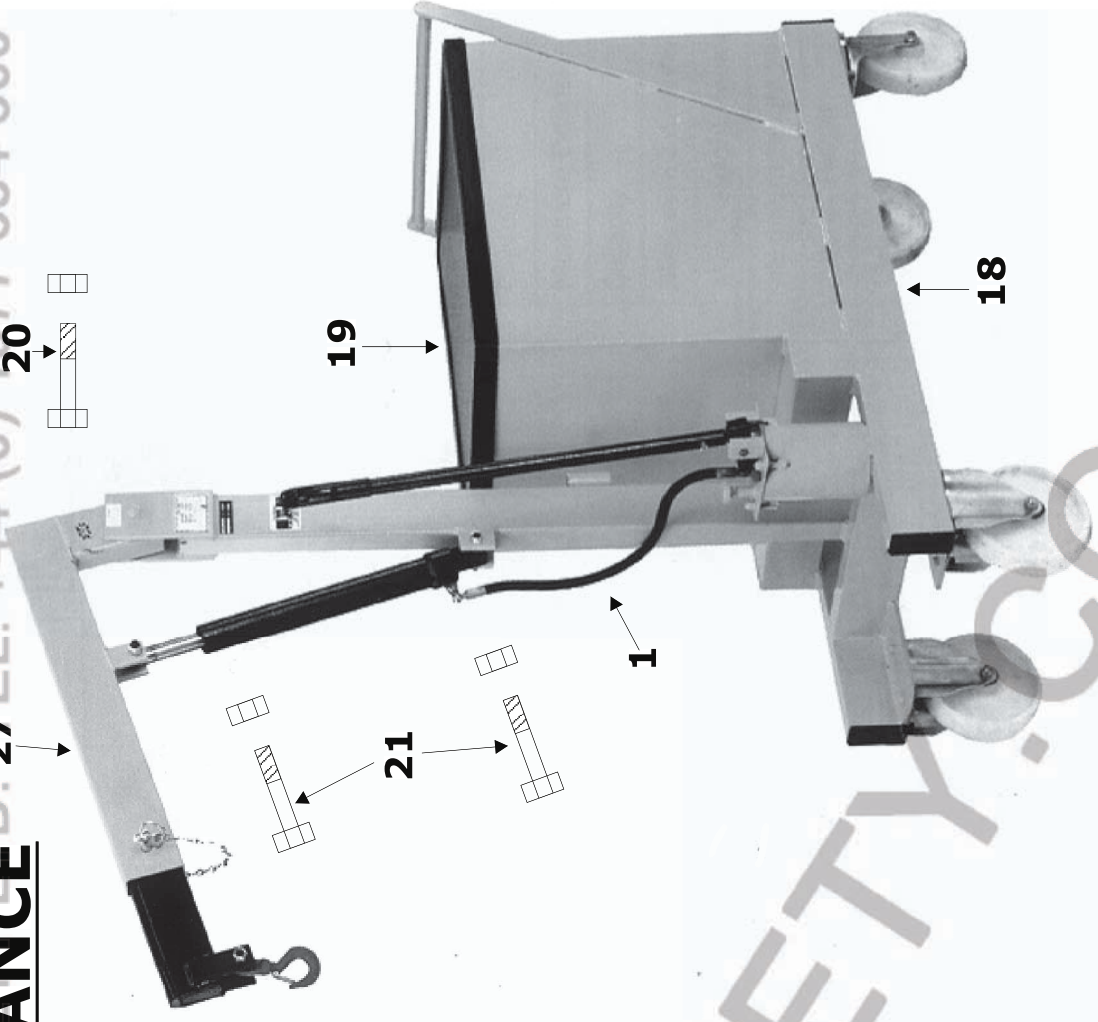
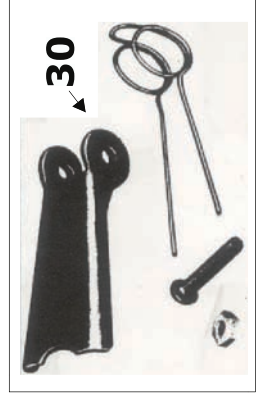
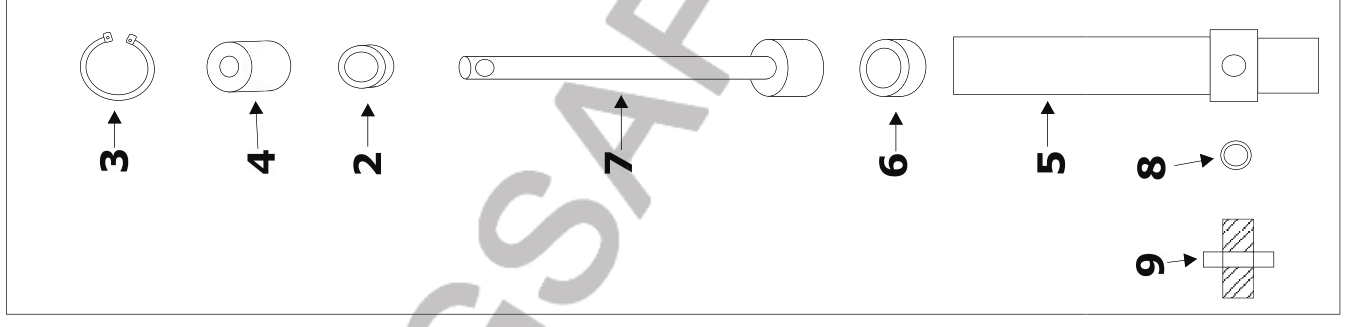
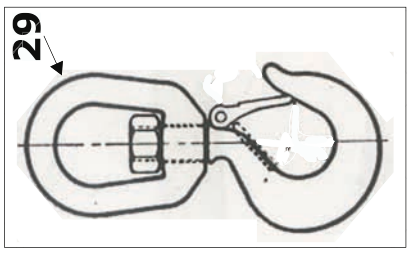
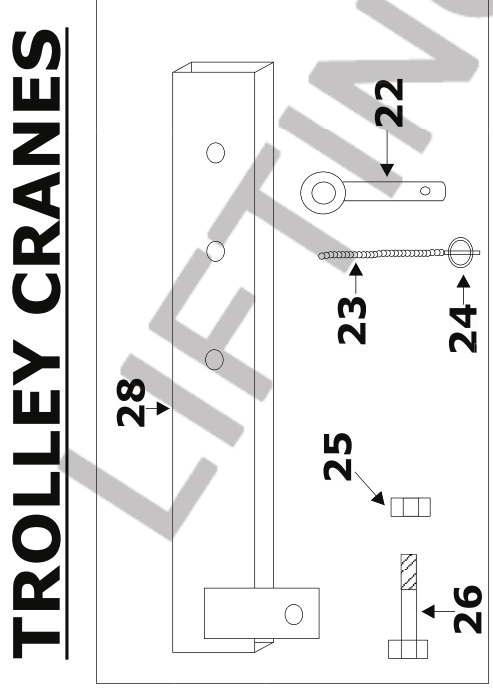

# **SPARE PARTS LIST FOR COUNTER BALANCE CRANES**

<b>PART NO.</b>	<b>DESCRIPTION</b>	<b>QTY.</b>
01	HYDRAULIC HOSE	1
02	SCRAPER RING	1
03	CIR-CLIP	1
04	GUIDE BUSH	1
05	HYDRAULIC CYLINDER	1
06	PISTON SEAL	1
07	PISTON ROD	1
08	DOWTY SEAL	1
09	HYDRAULIC FITTING	1
10	WHEEL BOLT	1
11	NUT	1
12	WHEEL BUSH	4
13	WHEEL	4
14	SWIVEL CASTOR COMPLETE	2
14A	FIXED CASTOR COMPLETE	2
15	SET SCREW	16
16	SPRING WASHER	16
17	PLAIN WASHER	16
18	MAIN FRAME	1
19	BALLAST BOX LID	1
20	JIB/COLUMN NUT AND BOLT	1
21	RAM NUT AND BOLT	2
22	JIB PIN	1
23	JIB PIN CHAIN	1
24	LYNCH PIN	1
25	HOOK NUT	1
26	HOOK BOLT	1
27	JIB	1
28	JIB EXTENSION	1
29	HOOK	1
30	HOOK SAFETY LATCH	1

## **Important Safety Information Read and Follow**

always inspect hook and latch before using.  
Never use a latch that is distorted or bent.  
Always make sure spring will force the latch against the tip of the hook.  
Always make sure hook supports the load. The latch must never support the load(see figure 1&2).  
When placing two or more

Loads may disengage from hook if proper procedure are not followed.  
A falling load may cause serious injury or death.  
A hook and this style latch must not be used for lifting personnel.  
Hook must always support the load. The load must never be supported by the latch.  
Read and understand these instructions before using hook and latch.