

Electric winches for loads of 300 to 7500 kg



This range of all-purpose electric winches for hoisting and pulling provides the perfect solution to all your needs with its wide range of loads and the considerable number of options available. What is more, the rugged design of this winch is a warrant for an extremely long service life requiring very little maintenance.

GENERAL CHARACTERISTICS

These winches are intended for lifting loads of 300 to 7500 kg (the forces indicated are for the final cable layer of the cable drum).

They comply with "EC" Directive 98/37/EC.

The type electric winches offer the following in the series production models:

- a 230/400 V – 50 Hz 3-phase electric motor.
- a low voltage electromagnetic brake with automatic take-up of wear.
- type IP 54 protection for the switchgear (cabinet and motor).
- an emergency stop pushbutton box on a 3 metres long spiral wound cable.
- an ON/OFF contactor.
- a 24 V low voltage transformer.
- a thermal cutout circuit-breaker.
- primary down gearing by an oil bath reduction box.
- secondary down gearing by gear under a cover (except for the T.E.C* 1).
- a modular design chassis amenable for changes (for instance a multiple choice of exits to lead out the cable from the drum).



OPTIONAL EXTRAS

This type of electric winch can be provided with electrical or mechanical options, or the following protection systems:

Tubular protective cradle for use on construction sites



Electronic load limiter

Upper travel and lower travel limit switches

Manual release of brake via actuating handwheel

Mechanical de-clutching of drum (except 300kg models)



2-speed motor or speed variator

Detection slack in cable

Grooved cable drum

Special length drum

Several cable exits on drum

Cable press roller

Radio control as alternative to pushbutton box

Cable connection on motor

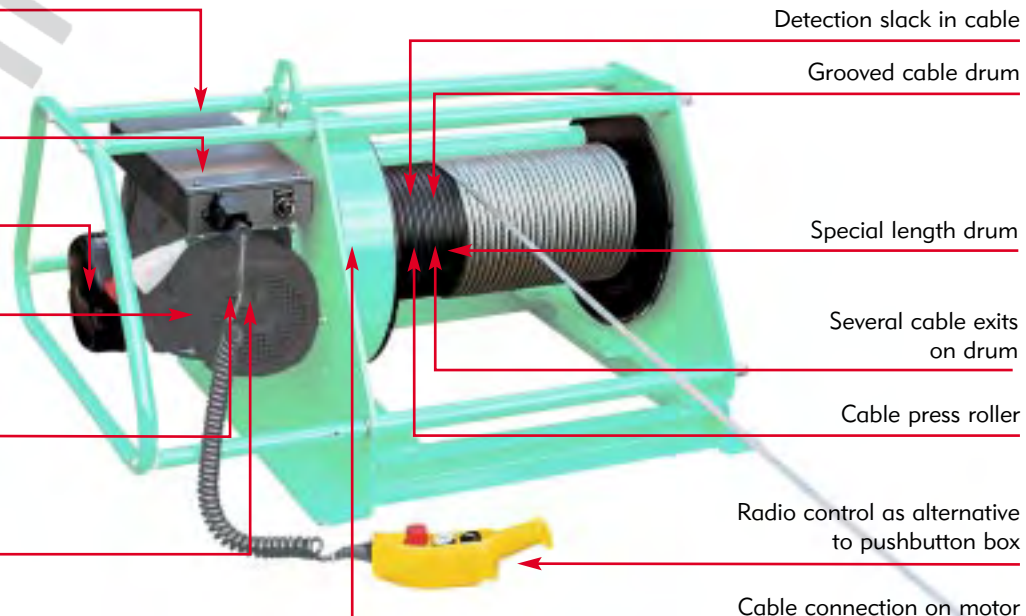

Electric winches for loads of 300 to 7500 kg

POSITIONS OF WINCH – CABLE EXITS – APPLICATIONS

The winch can be secured either to the floor (position A) or mounted as a wall bracket (position B and D) or again attached to the ceiling (position C). Position A is standard – the other positions (B, C and D) must be stipulated with the order.



The exit points are available anywhere around the full periphery (0 to 360°). The cable can be secured to the right or left of the drum, depending on the exit desired.

Cable exits

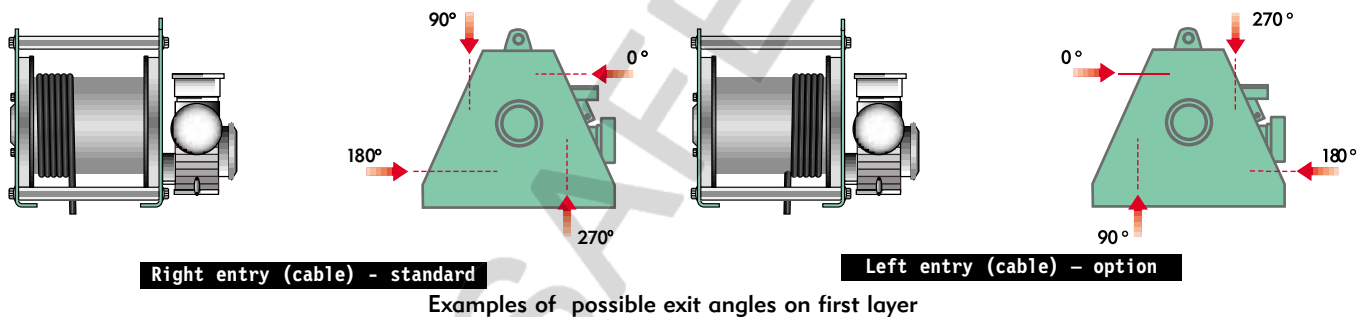

Typical applications

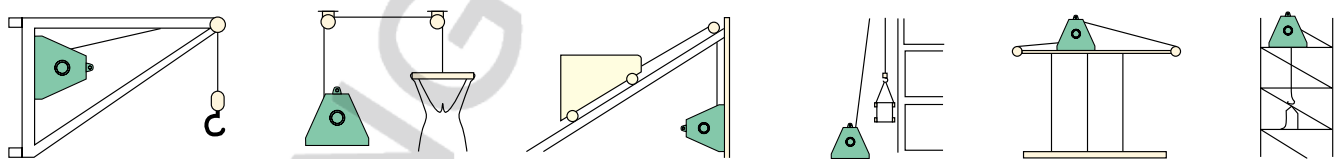

PRECAUTIONS DURING USE

The type T.E.C. electric winches have been designed to meet all requirements for lifting and pulling. This type of winch can be used either in the "lifting" function, with all the safety systems required under applicable regulations and standards, or the "pulling" function or towing or skidding.

Important! A minimum of three turns of cable wound onto the drum at the end of travel must always remain.

Requirements for using winches for towing or skidding

Optimum rolling requirements: calculation of the load that can be pulled will change in the light of the conditions of the moving element, namely the following parameters:

- Σ wheels mounted on roller bearing or not
- Σ wheel diameters (the greater the wheel diameter, the lower the pulling force needed)
- Σ the material of the wheels affects the coefficient of friction (rail, asphalt, concrete or sand) and, if there is one, the angle of slope).

When pulling, the force applied to the cable must never exceed the nominal load rating of the hoisting winch. Since it is extremely difficult to change the pulling load, (see paragraph above), we strongly recommend choosing equipment with an electronic load limiter to avoid all irreparable damage to your winch.

Electric winches for loads of 300 to 7500 kg

OVERALL DIMENSIONS – TECHNICAL CHARACTERISTICS

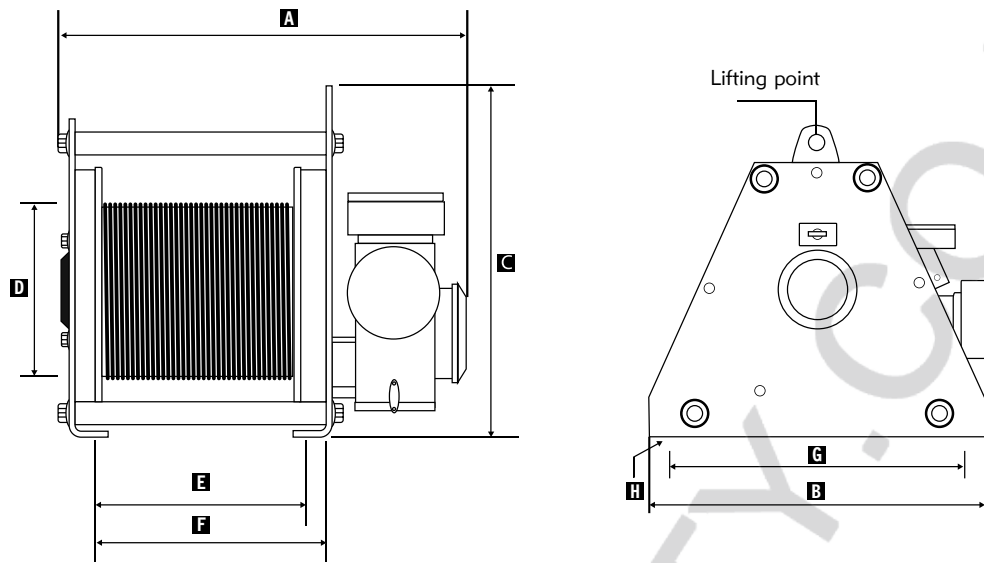

Type	Lifting force on final layer (kg)	Lifting force on first layer (kg)	Number of layers	Speed m/mn	Motor (kW)	Maximum cable capacity (m)	Cable diameter	A	B	C	Ø D	E	F	G	Ø H
EW 1	300	410	5	10	1,1	115	4,3	675	610	350	89	300	304	260	13
	300	410	5	15	1,5	115	4,3	675	530	350	89	300	304	260	13
	300	410	5	20	2,2	115	4,3	675	570	350	89	300	304	260	13
EW 2	600	790	5	10	2,2	170	6,8	875	640	510	159	400	476	460	18
	600	790	5	15	3	170	6,8	875	640	510	159	400	476	460	18
	600	790	5	20	4	170	6,8	875	640	510	159	400	476	460	18
	960	1320	5	10	3	150	8	875	640	510	159	400	476	460	18
	960	1320	5	15	4	150	8	875	640	510	159	400	476	460	18
	960	1320	5	20	5,5	150	8	875	640	510	159	400	476	460	18
EW 3	1000	1300	5	10	3	230	9	985	742	545	229	500	561	570	18
	1000	1300	5	15	4	230	9	985	742	545	229	500	561	570	18
	1300	1670	4	8	3	145	11,5	985	742	545	229	500	561	570	18
	1300	1670	4	16	5,5	145	11,5	985	742	545	229	500	561	570	18
	1600	2050	4	7	3	145	11,5	985	742	545	229	500	561	570	18
	1600	2050	4	12	5,5	145	11,5	985	742	545	229	500	561	570	18
EW 4	2000	2400	4	6	3	235	11,5	1210	1020	880	324	600	714	820	22
	2000	2400	4	10	4	235	11,5	1210	1020	880	324	600	714	820	22
	2600	3200	4	5	3	215	13	1210	1020	880	324	600	714	820	22
	2600	3200	4	9	5,5	215	13	1210	1020	880	324	600	714	820	22
	3300	4220	4	4	3	180	15,8	1210	1020	880	324	600	714	820	22
	3300	4220	4	7	5,5	180	15,8	1210	1020	880	324	600	714	820	22
EW 5	5000	6400	4	2	2,2	240	18	1480	1000	920	368	800	893	760	27
	5000	6400	4	5	5,5	240	18	1480	1000	920	368	800	893	760	27
EW 6	5000	6400	4	10	11	240	18	1490	1270	920	368	800	893	760	27
	7500	9500	4	4	7,5	240	22	1510	1200	1120	445	800	914	500/1000	27