

# Lebus® Load Binders



Load Rated

**SEE APPLICATION AND WARNING INFORMATION**  
 Para Español: [www.thecrosbygroup.com](http://www.thecrosbygroup.com) On Page 241

## A-1W



- Forged steel - Quenched and Tempered.
- Used as a come-a-long for short take-up on chain.
- Binder toggles away from the load.

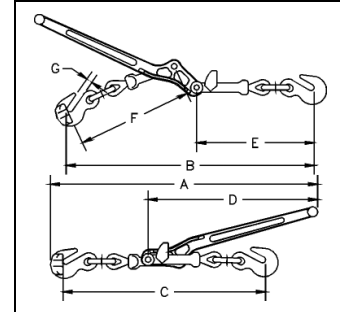

## A-1W Walking Load Binder

- Meets or exceeds DOT and CVSA Cargo Securement Tie-Down Guidelines, November 2003.

Model	Stock No.	Chain Size (in.)	Working Load Limit (lbs.)	Proof Load (lbs.)	Ultimate Load (lbs.)	Weight Each (lbs.)	Handle Length (in.)	Dimensions (in.)						
								A	B	C	D	E	F	G
A-1W	1048388	1/2 only	9200	18400	33000	13.10	18.69	28.75	25.75	21.25	18.69	12.31	12.38	.63

## R-10

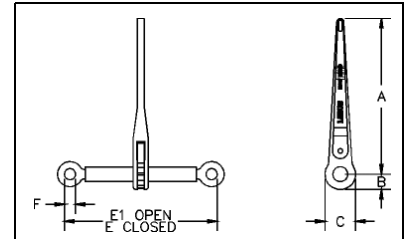

## R-10 Binder without Links and Hooks

- Meets or exceeds DOT and CVSA Cargo Securement Tie-Down Guidelines, November 2003.

Model	R-10 Stock No.	Working Load Limit (lbs.)*	Weight Each (lbs.)	Handle Length (in.)	Barrel Length (in.)	Take Up (in.)	Dimensions (in.)					
							A	B	C	E	E1	F
R-10	1048468	16000	8.04	14	10	8.0	14	1.38	2.75	14	22	1.00

\* Ultimate Load is 3 times the Working Load Limit.

Chain & Accessories