

Operating and Service Instructions, Spare Parts List

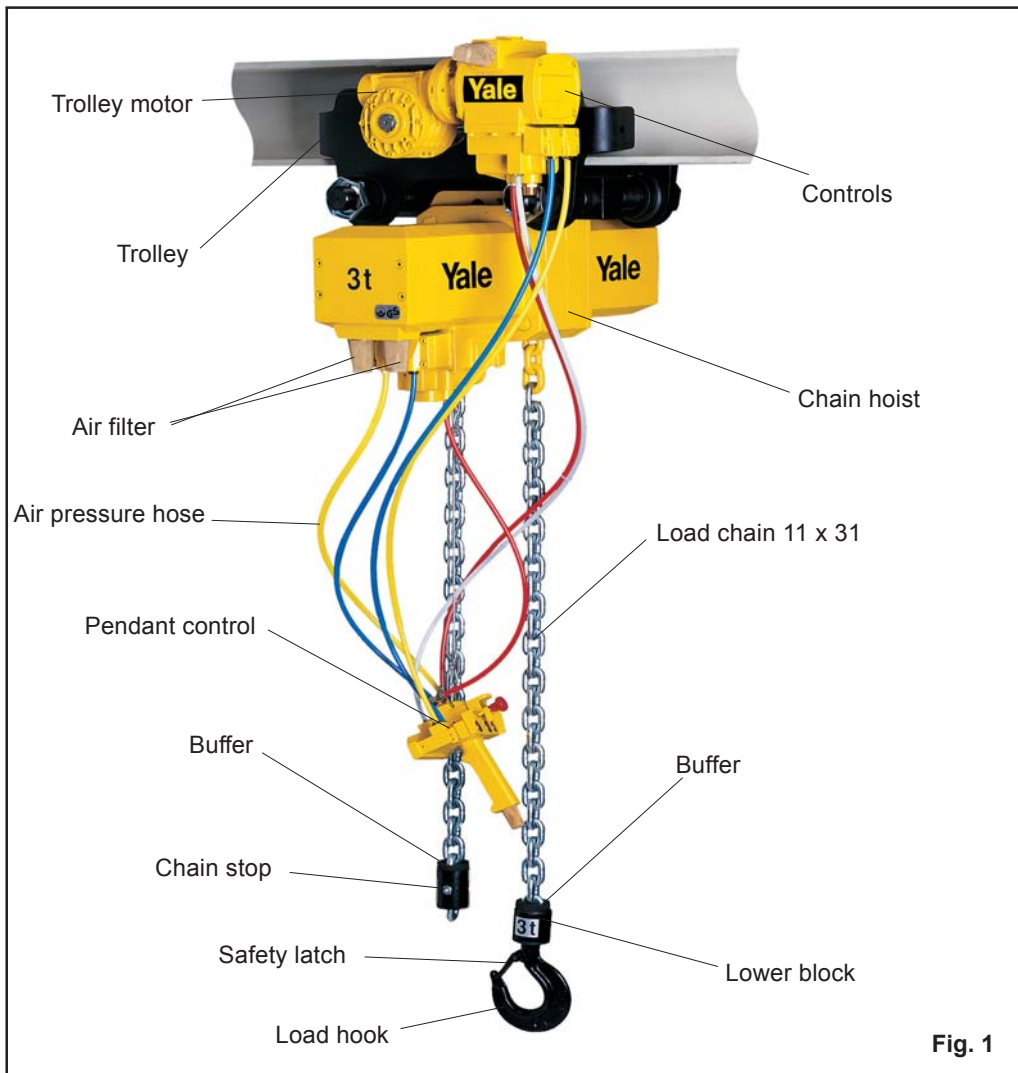

Model CPA

**Yale Industrial
Products GmbH**



Technical Data CPA

Model	Lifting capacity in kg/chain fall	Lifting speed with rated load* m/min	Lifting speed without load* m/min	Lowering speed with rated load * m/min	Motor rating kW	Weight with std. height 3m**			
						Hook design kg	Push trolley kg	Geared trolley kg	Motor trolley kg
CPA 20-8	2000/1	6,4	8,6	9,5	2,6	121	184	188	199
CPA 30-6	3000/1	5,2	8,6	11,3	3,2	121	184	188	199
CPA 40-4	4000/2	3,2	4,4	4,8	2,6	140	202	206	218
CPA 50-3	5000/2	2,9	4,4	5,2	3,0	140	202	206	218
CPA 60-3	6000/2	2,6	4,4	5,6	3,2	140	202	206	218

*Value at 6 bar (flow pressure)

Air consumption with rated load 4,7 m³/min

**Other lifting heights available

Technical Data Motor Trolley

Lifting capacity kg	Flange width mm	Size	Curve radius min. m	Motor trolley	
				Travel speed m/min	Motor rating kW
2000 - 6000	98 - 180	A	1,8	18	0,55
2000 - 6000	180 - 300	B	1,8	18	0,55

INDEX	PAGE
1. General information	3
2. Operating instructions	3
2.1 Correct operation	3
Capacity / max. safe working load	3
Danger zones	3
Attaching the hoist	3
Temperature range	4
Regulations	4
Maintenance/repair	4
2.2 Incorrect operation	4
2.3 Commissioning	4
inspection before initial operation	4
Inspection before starting work	4
Inspection of load chain	4
Inspection of chain stop	4
Inspection of chain reeving	4
Inspection of suspension and load hooks	5
Attaching the load	5
Inspecting the traverse (for trolleys)	5
Check adjustment of trolley width	5
3. Assembly	5
3.1 Inspection before assembly	5
3.2 Pneumatic chain hoist with hook suspension (Standard design)	5
3.3 Pneumatic chain hoist with trolley	5
Fitting the trolley	6
3.4 Air pressure connections	6
4. Functional check after assembly	6
5. Operation	7
Installation, service, operation	7
Traversing the trolley	7
Attaching the load	7
Lifting the load	7
Emergency stop	7
6. Service	8
6.1 Daily checks	8
6.2 Regular inspections, service, testing	8
6.3 Load chain	9
Lubricating the load chain	9
Inspecting the load chain for wear	9
Replace the load chain	9
Single fall design	9
Two-fall design	9
6.4 Load and suspension hooks	10
6.5 Trolleys	10
6.6 Pneumatic hoists in general	10
6.7 Overload protection device	10
6.8 Gearbox	10
Checkoil level	
Oil change	10
Disassemble and reassemble the gearbox	11
6.9 Air motor	12
Motor	12
Disassemble and reassemble the motor	12-13

1. GENERAL INFORMATION

Attention: All users must read these operating instructions carefully prior to the initial operation. These instructions are intended to acquaint the user with the hoist/trolley and enable him to use it to the full extent of its intended capabilities

The operating instructions contain important information on how to handle the hoist/trolley in a safe, correct and economic way. Acting in accordance with these instructions helps to avoid dangers, reduce repair costs and down time and to increase the reliability and lifetime of the hoist/trolley. Anyone involved in doing any of the following work with the hoist/trolley must read the operating instructions and act accordingly:

operation, including preparation, trouble shooting during operation and cleaning maintenance, inspection, repair transport

Apart from the operating instructions and the accident prevention act valid for the respective country and area where the hoist/trolley is used, also the commonly accepted regulations for safe and professional work must be adhered to.

Every unit leaving the factory is furnished with a test certificate showing the serial number of the hoist.

The continuous sound level at the place of work is equal to 75 dB. The measurement was taken at a distance of 2.2 m from the hoist in 1 position in accordance with DIN 45635 precision class 2.

2 OPERATING INSTRUCTIONS

2.1 CORRECT OPERATION

Capacity / max. safe working load

The Yale pneumatic chain hoist CPA is designed to lift and lower loads up to the rated capacity. The lifting capacity indicated on the hoist is the maximum safe working load which must not be exceeded.

Danger zones:

Do not lift or transport loads while personnel are in the danger zone.

Do not allow personnel to pass under a suspended load.

After lifting or tensioning, a load must not be left unattended for a longer period of time.

Start moving the load only after it has been attached correctly and all personnel are clear of the danger zone.

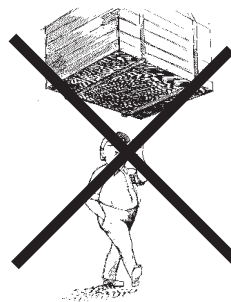

Fig. 2

Attaching the hoist

The operator must ensure that the hoist is attached in a manner that does not expose himself or other personnel to danger by the hoist, chain(s) or the load.

Temperature range:

The hoists can be operated in ambient temperatures between -10 °C and +50 °C.

Consult the manufacturer in case of extreme working conditions.
 Note: At ambient temperatures below 0 °C check the brake is not frozen.

Regulations

The accident prevention act and/or safety regulations of the respective country for using manual hoists must be strictly adhered to. In Germany these are VGB8, VBG9, VBG9a, ZHI/25, ZHI/27.

Maintenance / Repair:

In order to ensure correct operation not only the operating instructions, but also the conditions for inspection and maintenance must be complied with. If defects are found stop using the hoist immediately.

Attention: Before starting work on pneumatic components switch OFF the main air supply and secure it against unintentionally being switched back on.

2.2 INCORRECT OPERATION

- Do not exceed the rated capacity of the hoist.
 - Do not use the hoist for the transportation of people (fig. 3)
 - Welding on hook and load chain is strictly forbidden. The load chain must never be used as a ground connection during welding (fig. 4).
- Avoid side pull, i. e. side load on either housing or bottom block (fig. 5).

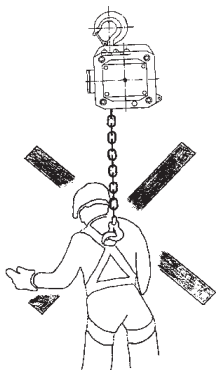

Fig. 3

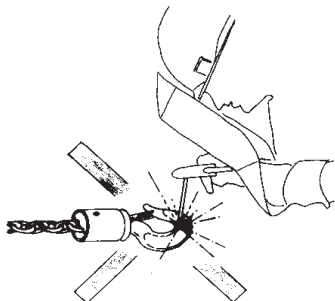

Fig. 4

- Lift/ pull/ tension only when load chain forms a straight line between both hooks.
- The load chain must not be used for lashing purposes (sling chain) (fig. 6).
- Do not knot or shorten the load chain by using bolts / screws / screwdrivers or other devices (fig. 7). Do not repair load chains installed in the hoist.
- Do not remove the safety latch from the suspension or load hooks (fig. 8).
- Do not use the chain stop as an operational limit device (see fig. 1 - chain stop)
- Do not throw the hoist down. Always place it properly on the ground.

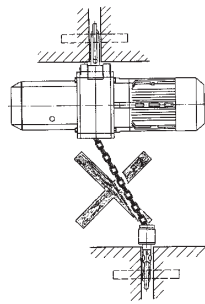

Fig. 5

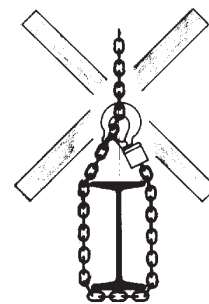

Fig. 6

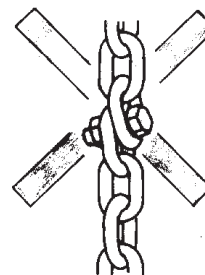

Fig. 7

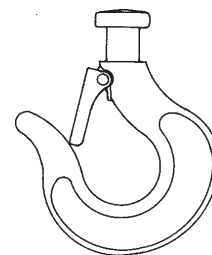

Fig. 8

2.3 COMMISSIONING

Inspection before initial operation

Each hoist must be inspected prior to initial operation by a competent person and any faults rectified. The inspection is visual and functional and shall establish that the hoist is safe and has not been damaged by incorrect transport or storage. Inspections should be made by a representative of the manufacturer or the supplier although the company can assign its own suitably trained personnel. Inspections are instigated by the user.

Inspection before starting work:

Before starting work inspect the hoist, chain(s) and all load bearing constructions every time for visual defects. Furthermore test the brake and that the load and hoist are correctly attached by carrying out a short work cycle of lifting/pulling or tensioning and releasing. The selection and calculation of a suitable suspension point for the hoist is the responsibility of the user.

Inspection of load chain:

Inspect the load chain for sufficient lubrication and visually check for external defects, deformations, superficial cracks, wear or signs of corrosion.

Inspection of chain stop:

The chain stop must be connected to the free (idle) chain strand (see fig. 1 - chain stop).

Inspection of chain reeving:

All units equipped with two or more chain strands should be inspected prior to initial operation for twisted or kinked chains. The chains of two strand hoists may be twisted if the bottom block was rolled over (see fig. 9).

Inspection of suspension and load hooks

Inspect suspension and load hooks for deformations, damage, cracks, wear or signs of corrosion.

Attaching the load

The load must always be seated in the saddle of the hook. Never attach the load to the tip of the load hook. This also applies to the suspension hook (fig. 10).

Inspecting the traverse (for trolleys)

Inspect the traverse for correct assembly and visually check for external defects, deformations, superficial cracks, wear or signs of corrosion. In particular check that the roll pins in the centre traverse have been fitted correctly (fig. 12)

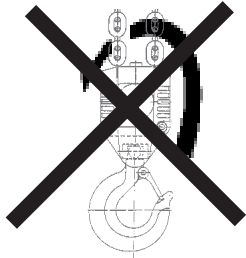

Fig. 9

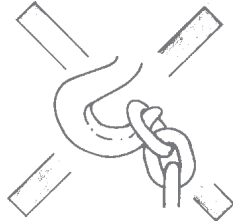
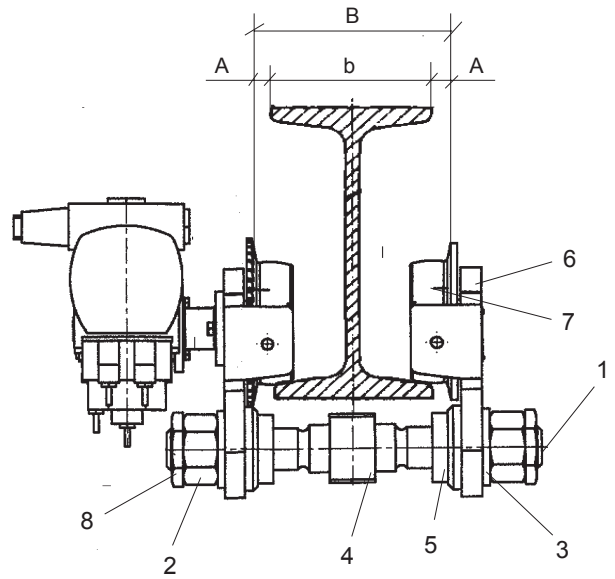

Fig. 10

Check adjustment of trolley width

On chain hoists without suspension hook (CPA-VTP/G/E) check that the clearance between the trolley wheel flange and the beam outer edge is equal on both sides and within the tolerances given (see page 6). Enlarging the clearances, e.g. to enable the trolley to negotiate tighter curves, is forbidden.



No. Description

- 1 Traverse
- 2 Nut
- 3 Washer
- 4 Centre traverse
- 5 Round nut
- 6 Sideplate
- 7 Roller
- 8 Locking nut

3 ASSEMBLY

3.1 Inspection before assembly

- Check for transport damage
- Check for completeness
- Check that the lifting capacity of hoist and load hook match

3.2 Pneumatic chain hoist with hook suspension

(Standard design)

The standard Yale pneumatic chain hoist is fitted with a suspension hook.

The suspension hook is connected to the hoist with two suspension pins. Independent of how the hoist is reeved it must always hang vertically under the suspension hook. In single-fall operation the suspension hook is to be installed centred on the marking 1/1, for dual-fall operation centred on the marking 2/1 (see fig. 11).

Attention: Secure the two suspension pins with the locking plate after assembly.

The selection and calculation of a suitable suspension point is the responsibility of the user and must be adequate to support the hoist while it is being operated at its maximal lifting capacity.

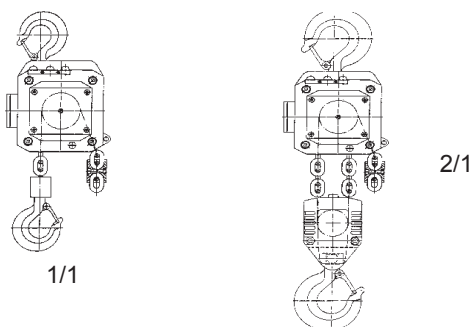

Fig. 11

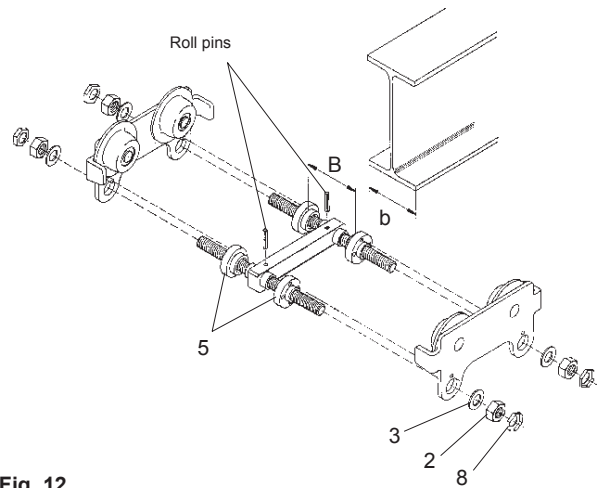

Fig. 12

3.3 PNEUMATIC CHAIN HOIST WITH TROLLEY

The trolleys are supplied pre-assembled for beam widths A or B (see table 1). This is shown on the nameplate. Before installation ensure that the trolley width is correct for the intended carrying beam.

Beam width	Flange width [mm]		Flange thickness [mm]
	from	to	max.
A	98	180	27
B	180	300	27

Fitting the trolley (see fig. 12)

- 1.) Unscrew the locking nuts (pos. 8) and securing nuts (pos. 2) from the traverses (pos. 1) and remove the side plates (pos. 6).

2.) Measure the flange width "b" of the beam.

3.) Adjust the measurement "B" between the shoulders of the round nuts (pos. 5) on the threaded traverses (pos. 1).

Ensure that the 4 bores in the round nuts face towards the outside. Adjust the measurement "B" to equal the measurement "b" plus 4 mm. The measurement "A" must be 2 mm on each side and the suspension traverse must be centred between the shoulders of the round nuts.

4.) Replace one side plate (pos. 6).

Replace one side plate ensuring that the roll pins in the side plates engage into the bores in the round nuts. To achieve this it may be necessary to rotate the round nuts slightly.

5.) Replace the washers (pos. 3) and tighten the securing nuts (pos. 2). Screw on the locknuts (pos. 8) fingertight and tighten a further 1/4 to 1/2 turn.

Attention: The locknuts must always be fitted.

6.) Loosely replace second side plate (pos. 6) on the traverse (pos. 1):

The washers (pos. 3), security nuts (pos. 2) and locknuts (pos. 8) can be fitted loosely.

7.) Raise the complete pre-assembled trolley to the carrying beam.

8.) Engage the second side plate ensuring that the roll pins in the sideplate engage into the bores in the round nuts To achieve this it may be necessary to rotate the round nuts slightly.

9.) Tighten the security nuts (pos. 2) on the second sideplate. Tighten the locknuts (pos. 8) fingertight and then a further 1/4 to 1/2 turn.

Attention: The locknuts must always be fitted.

10.) By traversing the trolley check following:

That a clearance of 2 mm on each side between the trolley wheel flanges and beam edge is maintained.

The centre traverse is centred below the beam.

That all 4 locknuts are fitted and secured.

11.) Model CPA-VTG only

To fit the handchain, position the slot on the outer edge of the hand chain wheel below the chain guide. Place one link of the hand chain vertically into the slot and turn the hand wheel until the link has passed the chain guides on both sides.

Attention: Do not twist the hand chain when fitting.

Pulling the hand chain moves geared trolleys

3.4 AIR PRESSURE CONNECTIONS

Attention

The brake opening pressure for the disc brake is: min. 2.6 bar. The "hold open" pressure of 3 bar must be maintained, to ensure that the brake lining does not constantly slip on the pressure plate.

The operating pressure is 4 - 6 bar.

The compressed air must be clean and enriched with oil to guarantee adequate lubrication. We, therefore recommend the use of an oiler that works on the ram-air principle with an adjustable jet. 1 cm³ of oil amounts to 25 – 30 drops, 2 – 5 drops are required for every m³ of air used under normal conditions (see following table).

In any case a lubricator unit comprising of a filter and an oiler with a pressure regulator in-between (regulator independent of supply pressure, adjustable and with pressure gauge). When choosing a unit consider the rate of flow and ensure it is not fitted more than 5 m away from the hoist.

The lubricant can be replenished in service without disconnecting the air supply.

For the oiler we recommend a resin and acid free lubricating oil (SAE 5W – SAE 10W), as thicker oils tend to clog the vanes and reduce the performance of the motor.

The air hose should have a diameter of at least 19 mm. The connection is R1".

The connections on the control pendant must not be exchanged.



Operating pressure (flow pressure)	P	4	5	6	bar
Motor rating	P	2	2,75	3,2	kW
RPM (under load)	n_{bel}	2500	2800	3200	1/min
RPM (unloaded)	n_{leer}	4600	5200	5700	1/min
Air consumption at P_{Nenn}	V	2,9	3,9	4,7	m ³ /min

4. FUNCTIONAL CHECK AFTER ASSEMBLY

Prior to operating the hoist, grease the trolley pinions (manual and motor trolleys) and lubricate the load chain when it is not under load (see page 8).

Before the hoist is put into regular service, following inspections must be made:

- Are all screwed connections on the hoist and trolley tight and are all locking devices in place and secure?
- Are the end stops on the trolley runway in place and secure?
- Is the hoist correctly reeved?
- Is the chain stop correctly fitted to the loose end of the load chain (see fig. 1).
- All units equipped with two or more chain strands should be inspected before initial operation for twisted or kinked chains. The chains of two fall hoists may become twisted if the bottom block is rolled over.
- Perform an operating cycle without load. The chain should move in a steady, smooth way. Check the function of the overload device (max. 5 sec.) by raising the bottom block against the hoist body.
- Check the brake function when lifting and lowering. The braking distance must not be more than 50 mm.
- Traverse the trolley the complete length of the trolley runway ensuring that the 2 - 4 mm clearance between the trolley wheel flange and the beam edge is maintained at all times. Check that the beam end stops are positioned correctly and secure.

5. OPERATION

In addition to the recommendations in section 1, following rules must be strictly maintained to ensure the safe operation of the hoist

Installation, Service, Operation

Users delegated to install, service or independently operate the hoist must have had suitable training and be competent. Users are to be specifically nominated by the company and must be familiar with all relevant safety regulations.

Traversing the trolley

Hand trolleys: Pull on the load chain.

Attention: never pull on the air hoses

Geared trolleys: By operating the hand chain

Motor trolleys: By operating the "left" button or "right" button on the LH side of the pendant control.

Consider the braking distance of the trolley. Do not use the beam end stops as operational limit devices.

Attaching the load

Attach the load to the hoist using only approved and certified slings / lifting gear. The load must always be seated in the saddle of the hook. Never attach the load to the tip of the hook. Never remove the safety latch from suspension or load hooks.

Lifting the load

The load is lifted by depressing the "up" button, it is lowered by depressing the "down" button on the RH side of the pendant control. Do not use the chain stop as an operational limit device (see fig. 1).

Emergency stop

All movement can be immediately halted by depressing the red, mushroom shaped button on the pendant control.

Attention: The hoist is still filled with air. To release the emergency stop, pull the button out again.

6. SERVICE

Service and inspections may only be carried out by a competent person.

The inspection must determine that all safety devices are present and fully operational and cover the condition of the hoist, lifting gear, accessories and supporting constructions. The service intervals inspections noted are for normal working conditions. Adverse working conditions e.g., heat or chemical environments can dictate shorter periods.

Yale pneumatic hoists conform to the machinery group 1AM resp. 1Bm in accordance with FEM 9.511. This results in a theoretical service-lifetime of 800 resp. 400 operating hours under full load. This is equivalent to 10 years under normal operating conditions. After this period the hoist requires a general overhaul. Further information is contained in VBG 9 resp. FEM 9.755.

6.1 DAILY CHECKS

- 1.) Visually check the pendant control unit and air hoses for damage.
- 2.) Check that the brake functions correctly.
- 3.) Check that the overload safety device functions correctly.
- 4.) Chain hoists with trolley:
 - Check that the trolley runway is free from obstructions.
 - Check that the end stops on the trolley runway are fitted and secured.

6.2 REGULAR INSPECTIONS, SERVICE, TESTING

According to national and international safety regulations hoisting equipment must be inspected annually by a competent person. Adverse working conditions e.g., heat or chemical environments can dictate shorter periods.

The commissioning and inspection details can be noted in the enclosed inspection sheet.

Repairs may only be carried out by specialist workshops that use original Yale spare parts.

Attention: Disconnect the air supply before performing test unless air is required for a particular test.

Inspections and service work	Initial inspection			Interval inspection		
	when commissioning	after 50 service hours	after 200 service hours	daily	after 200 service hours	annual
Compressed air components compressed air supply	•					•
Press-button control Strain relief	•	•		•		
Lubricate load chain	•	•	•		•	
Check for wear in chain drive		•	•		•	
Function of slip clutch	•			•		
Function of brake	•			•		
Chain bolts for cracks		•				•
Check suspension and load hooks for cracks and deformation		•				•
Screwed connections for tightness		•				•
Check trolley for cracks and deformation		•				•
Oil level in gearbox	•	•			•	
Oil change, gearbox			•			•
Check hoist motor and gearbox						•
Check trolley motor and gearbox						•
Grease drive transmission						•
Grease lower block	•		•			•

6.3 LOAD CHAIN

The Yale load chain is quality class 8 chain with the measurements 11 x 13. Yale electric hoists are specially designed to use this type of chain. For this reason only chains that have been approved by the manufacturer may be used in these hoists.

Lubricating the load chain

The load chain is to be lubricated before initial operation and every 3 months but at the latest after 200 operating hours. Adverse working conditions, e.g. excessive dust or continued heavy duty can dictate shorter periods between lubrication.

Before the chain is lubricated it must be cleaned. Flame-cleaning is forbidden. Use only cleansing methods and agents that do not corrode the chain material. Avoid cleansing methods that can lead to hydrogen brittleness, e.g. spraying or dipping chain in caustic solvents. Also avoid surface treatments that can hide cracks and flaws or other surface damage.

The chain must be lubricated in a no-load condition so that lubricant can enter between the links, e.g. by dipping in oil. The whole chain must be lubricated.

Motor oil of the viscosity class 100, e.g. Shell Tonna T68 can be used to lubricate the chain. For very dusty applications use a dry lubricant.

Inspecting the load chain for wear

Load chains must be inspected every three months or at the latest after 200 operating hours (see VBG8 § 27 or local specifications).

Visually inspect the chain over its full length for deformation, cracks, flaws, elongation, wear or corrosive pitting.

Link chains must be replaced when the nominal thickness "d" on any part of the chain has been reduced by more than 10% (see fig. 4) or when the partition "t" is elongated by more than 2% or over 11 partitions (11 x t) by 2%. Nominal dimensions and wear limits are shown in following table.

Chains that do not fulfil all requirements must be replaced immediately.

Link chain 11 x 31 min. quality class 8			
Inspection	Dim.	Nominal value [mm]	Limit value [mm]
Elongation over 11 partitions	11 • t	341	347
Elongation over 1 partition	t	31	32
Average link thickness	$\frac{d_1+d_2}{2}$	11,3	10,2

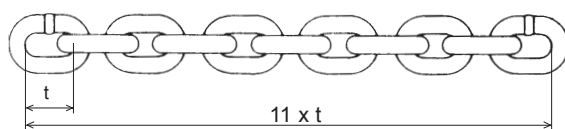

d = nominal thickness of chain
 d₁, d₂ = Actual value

$$d_m = \frac{d_1 + d_2}{2} \leq 0,9 d$$

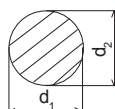

Replace the load chain

Single-fall design

1.) Disassemble lower block

Remove the circlip with suitable pliers. Raise the swivel tube in the direction of the chain and tap out the chain pin with a drift.

Attention: Do not damage the chain pin bore.

2.) Remove the chain stop

Remove the 2 screws and remove the chain stop. The chain is now free.

3.) Fitting the new chain

Cut the second to last link open on the loose end of the load chain to form a "C". Remove the last link and connect the new chain. The new chain must be fitted so that the welds on the standing links face towards the chain guide and away from the chain wheel. Operate the hoist in the "lift" direction to feed the new chain through the hoist.

4.) Fitting lower block and chain stop

Slide the end buffers over the chain ends and refit lower block and chain stop. The chain stop must be fitted so that at least 1 link remains free (see fig. 1).

5.) Before initial operation lubricate the unloaded chain and test all hoist functions under a no-load condition

Two-fall design.

1.) Remove the chain anchor pin

The chain anchor pin is situated on the underside of the hoist body. With an Allen key remove the grub screw that serves as the locking device. Tap out the chain anchor pin from the other side with a drift.

Attention: Do not damage anchor pin or bore.

2.) Pull the load chain through the lower block and remove the chain stop.

3.) Fitting the new chain

Cut the second to last link open on the loose end of the load chain to form a "C". Remove the last link and connect the new chain. The new chain must be fitted so that the welds on the standing links face towards the chain guide and away from the chain wheel. Operate the hoist in the "lower" direction to feed the new chain through the hoist.

4.) Replace chain stop

Slide the buffer pad over the loose end of the load chain and refit chain stop ensuring that at least one link remains free (see fig. 1).

5.) Fitting the chain anchor pin

Inspect the chain anchor pin for flaws, cracks or burrs. Thread the load chain, ensuring it is not twisted, through the lower block. Enter the last link of the load chain into the slot in the underside of the hoist body and enter the anchor pin through the side bore. Move the last link back and forth while entering the anchor pin to ensure that it is not trapped and damaged by the anchor pin. Secure the chain anchor pin with the grub screw.

6.) Assemble the lower block

Check the chain wheel for damage. Grease the needle bearings in the lower block halves. Place the load hook and the buffer in the slots provided in one lower block half. Wrap the load chain around the chain wheel ensuring that the chain is not twisted and that the welds on the standing links face away from the chain wheel. Engage the chain wheel, with load chain, into the pre-assembled lower block half. Ensuring that the buffer pad is situated correctly in its groove replace the second lower block half and secure with the screws.

7.) Functional test

All units with two or more chain strands must be inspected before initial operation for twisted or kinked chains. Chain strands may become twisted if the lower block is rolled over. If a strand is twisted disconnect it from the hoist and re-thread it correctly. In some cases it may be necessary to remove the last link

8.) Before initial operation lubricate the unloaded chain and test all hoist functions under a no-load condition.

6.4 LOAD AND SUSPENSION HOOKS

Inspect the hooks for deformation, damage, surface cracks, wear and signs of corrosion as required **but at least annually**. Adverse working conditions may dictate much shorter periods. Hooks that do not fulfil all requirements must be replaced immediately. Welding on hooks to compensate for wear or damage is not permissible. Hooks must be replaced when the mouth of the hook has opened more than 10% (fig. 14) or the nominal value of other dimensions has decreased by 5% due to wear. Nominal dimensions and wear limits are shown in the following table. Discard all hooks that do not fulfil all the requirements of the following table.

Inspection	Dim.	CPA 20 / 30		CPA 40 / 50 / 60	
		Nominal [mm]	Limit [mm]	Nominal [mm]	Limit [mm]
Hook saddle	b ₂	24	22,8	29,5	28
Hook saddle	h ₂	35	33,2	44,5	42,3
Mouth dimension	a ₂	43	47,3	54	59,4

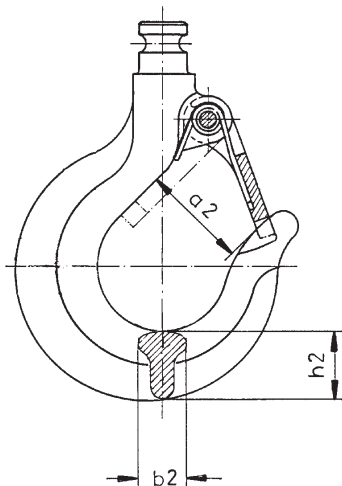

Fig. 14

6.5 TROLLEYS

In particular check following parts:

- Sideplates:
For cracks or deformation in particular around the areas of screwed connections.
- Trolley wheels:
Visually check for cracks. Wear on trolley wheel flanges. Grease the transmission.
- Traverses:
In particular around threaded areas for cracks.
- Fasteners:
Check nuts, screws and locking devices for tightness.

6.6 PNEUMATIC HOISTS IN GENERAL

In particular check following parts:

- Threaded connections in general
Check all nuts, screws and locking devices for tightness.
- Chain bin
Ensure the bin is secure. Check for tears or wear
- Suspension bolts
(Connection between hoist and suspension hook resp. trolley)
Check for cracks or wear. Ensure all safety devices are in place and secure.

6.7 OVERLOAD PROTECTION DEVICE

The overload protection device is factory set to 110% +/- 10% of the rated lifting capacity and can be checked by lifting a suitable load. If the device slips at the rated capacity load it can be adjusted as follows (see fig. 19):
 Remove the screws (52) that retain the gearbox cover (51). Loosen the set screw (47) that presses the steel ball (46) onto the housing. Turn the adjuster (42) clockwise to increase the tension. Re-check the adjustment with a suitable load. Secure the set screw (47) with a suitable locking agent, e.g. loctite 243. Replace the gearbox cover (51) and secure with screws (52).

6.8 GEARBOX

The gearbox is practically service-free. Service is therefore reduced to checking the oil level and changing the oil.

Check oil level

Ensure that the hoist is horizontal and has been stationary for at least 30 minutes (this allows the oil to drain to the lower part of the gearbox). Remove the fill-plug. Oil should be up to the lower edge of the fill hole.

Oil change

The oil (around 0,3 l) is to be changed every 5 years or at the latest after 400 operating hours.
 Remove the screws (52) that retain the gearbox cover (51). Remove the fill-plug (44). Tip the hoist vertical so that the oil can drain from the fill hole into a suitable container (can take up to 30 min.). Replenish the gearbox oil. We recommend a mineral oil viscosity class ISO-VG 460 e.g. FINA GIRAN L 460. Finally re-adjust the overload protection device and secure the screw with a locking-agent, e.g. Loctite 241.

Disassemble and reassemble the gearbox

Attention: The gearbox has oil lubrication

Disassemble (see fig. 19)

1. Remove the coupling (50) from the shaft (35). Remove the screws (52) and remove the gearbox cover (51).
2. Remove the filler plug (44) and gasket (45)
3. Stand the gearbox upright and drain the oil into a suitable container.
4. Loosen the set screw (47) and remove the steel ball (46). Unscrew the adjuster (42).
5. Remove the cup spring (41).
6. Remove the locking screw (38) and remove the retention pin (39).
7. Remove the circlip (37), bearing plate (33) and bearing (36). Remove circlip (34) and press the bearing (36) out of the bearing plate (33). Remove the circlip (37) from the gearbox shaft (35).
8. Remove brake disks (28) and gear ring (29).
9. Remove planet gears (32), needle bearing (31), thrust washer (30), planetary gear shaft (27) and pinion gear (26). Remove gearbox shaft (35).
10. Remove set screw (17).
11. The remaining parts within the housing (1) can be removed from the flange side. It is helpful to tap the edge of the body in an axial direction (flange end) with a wooden or rubber hammer to loosen the bearing end plate (15).
12. Remove the planet gears (25), needle bearings (24) and thrust washers (23) from the planet carrier (22).
13. Remove planet carrier (22) and pinion (21) from the planet carrier (3).
14. Remove bearing (20) and bearing plate (15) from the planet carrier (3).
15. Remove the circlip (11) from the planet carrier (3) and press out the planet wheel shaft (10).
16. Remove planet wheels (7), needle bearings (8), thrust washers (6) and spacer ring (9).
17. Remove bearing (5) and seal (4).

Clean and inspect all parts. Replace all worn or damaged parts and the gearbox is ready for reassemble.

Expendable parts are:

thrust washers (6, 23, 30), needle bearings (8, 24, 31), O-Rings and seals (4, 16, 18, 43) and the seal (45)

Reassemble

Reassemble the gearbox in the reverse order according to the sectional drawing (see fig. 19).

Take great care to fit the planet gears (7) with needle bearings (8) of the same sort, thrust washers (6) and spacer washers (9) properly into the planet carrier (3).

The brake disks either side of the gear ring (28) must be steeped in oil (soak for one hour in oil) before they are fitted. The exact adjustment of the overload device is first possible when the unit is completely reassembled. A preliminary adjustment is made by compressing the cup springs (41) with the adjuster (42). Once the final adjustment has been made secure the adjustment with the set screw (47) and steel ball (46).

Fill the gearbox with around 0,3l gearbox oil (CLP 460 according to DIN 51547).

Replace plug (44) and gasket (45).

6.9 AIR MOTOR

Motor

The length of the motor's working life is influenced greatly by the factors:

- a) cleanliness of the air supply
- b) lubrication conditions and service

to a) if water and rust can build up inside the air supply system dirt and water traps must be fitted.

to b) Always use resin and acid free oil (SAE 5W - SAE 10W). Thicker oils clog the vanes and reduce the speed and power of the hoist. An optimal lubrication extends the working life of the motor considerably. We highly recommend that service and oiler units are fitted.

Adjust the oiler so that for every m³/min. of air consumed around 2 - 5 drops of oil are sprayed.

Expendable parts - in particular the vanes - should be replaced on time. They are worn when their height is less than 25 mm. We also recommend that the O-Rings (18) that serve as start-up helps are also be replaced.

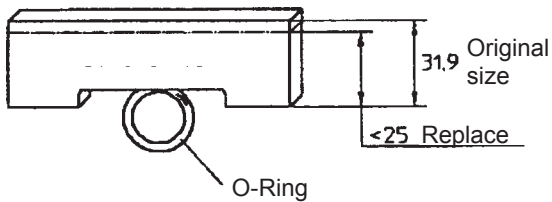

One of the main expendable parts are the brake linings (44). The lining thickness should be controlled at regular intervals as the wear affects the efficiency of the brake to hold.

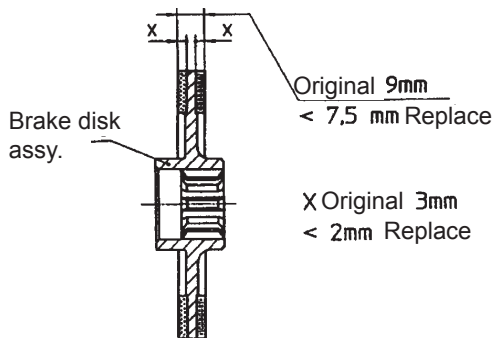

The brake disk must be replaced when it's total thickness becomes less than 7.5 mm or if the brake lining on any side is less than 2 mm thick.

Disassemble and reassemble the motor

Disassemble - vanes and brake disk

1.) Change vanes (see fig. 20)

Remove the screws (27), end plate (25) and cup spring (24). With the help of a puller remove the seal plate with bearing (20) from the rotor. Remove the spacer (23). Remove the vanes (17) from the rotor slots.

If a puller is not available the complete internal parts can be removed to be further disassembled on the workbench.

To remove the sealing plates (5) and (20) it can be helpful to tap the rotor shaft ends on a wooden surface. The motor cylinder (9) can now be removed and the vanes can be extracted from the rotor slots. Before replacing new vanes clean the rotor slots from oil and resin residues. The new vanes must move freely in the rotor slots (12).

2.) Renew the brake disc

Remove screws (33) and motor end cover (32). Remove the screws (55). **ATTENTION:** the springs (53) are under tension. Remove the brake housing cover (54) and springs (53). Withdraw the air brake housing (46) complete with parts (47 - 52) from the brake housing (40). Note the O-Ring (45). Remove the brake disc (44) from the rotor shaft and check the lining thickness.

Before reassemble clean the brake housing (40) pressure plate (51) from brake dust.

Coat the rotor shaft end (12, spline) and the inner spline of the brake disc (44) with an antirust paste (e.g. Altemp Q NB 50) to ensure that the brake disc (44) can move freely on the rotor (12) spline. Repeat this procedure on the pressure plate spline (51) and the brake housing (40).

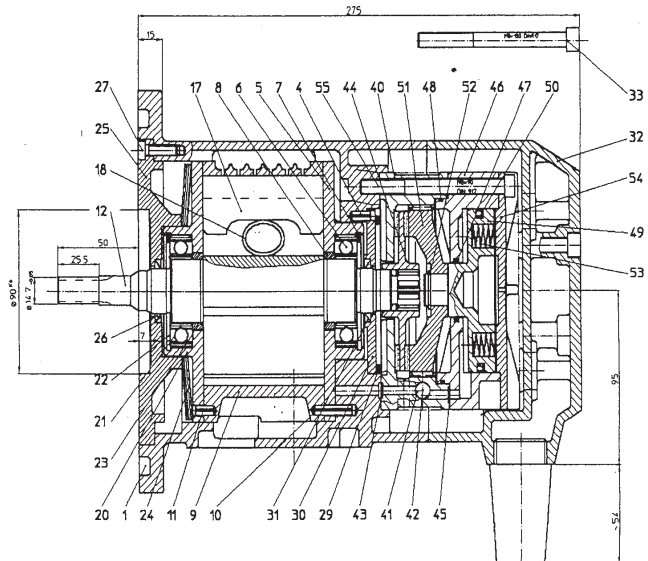

3.) Complete disassembly

Once the motor parts have been removed as described in 1.) and the seal plates (5 and 20) have been removed from the rotor, the motor cylinder (9) and vanes (17) can be removed, if required, the bearings (6 and 21) can be removed from the seal plates (5 and 20) by releasing the circlips (7 and 22). Remove the complete control valve from the motor body (1). Remove the screws (55) and withdraw the brake assembly (40 - 54) from the body (1). Remove the O-Ring (29), seal plate (30) and oil seal (31). Normally the silencer (2) remains in the body (1) and is only removed if defect.

The brake unit is, in part, disassembled as described in 2.). After removing the circlip (52) the pressure plate (51) can be removed from the air brake piston (49) this, in turn, can now be removed from the air brake housing (46). If the exchange valve function in the brake housing (40) is defect release the spacer screws (42) and remove the control piston (41).

Reassemble

In the main reassemble is performed in the reverse order to disassembly.

Pay attention to the motor clearances.

The axial play between the rotor (12) and the seal plates (5 and 20) should be around 0.04 mm

The broken edges on the spacer rings (8 and 23) must face in toward the middle of the rotor

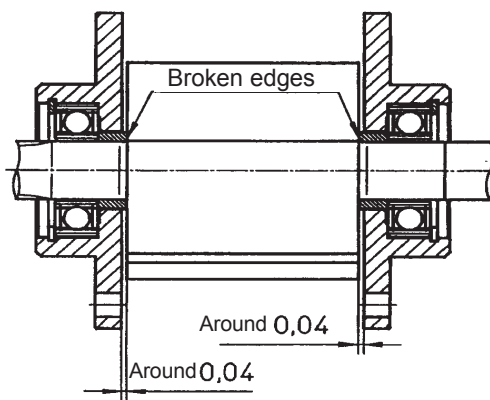

Before replacing the vanes (17) clean the rotor slots from oil and resin residues. The new vanes must move freely in the rotor slots (12). Grease the bearings (6 and 21).

ATTENTION: If the bearings (6 and 21) have been renewed the clearances must be readjusted (see drawing above). Ensure that the bearing inner race is pressed, without play, against the circlip to set the spacer ring (8 and 23) clearances (new spacer rings must always be adapted). After fitting the motor cover (25) the rotor (12) must rotate freely. If the rotor is hard to rotate or does not rotate at all it can be helpful to apply light taps with a rubber hammer to the motor housing (1, to the side or axially) to seat the rotor (12) and remove tensions. Replace the oil seal (31) and seal plate (30). Take care not to damage the sealing lips! Position the O-Ring (29) and replace the brake housing (40) complete with change valve. Remember to position O-Ring (43).

Apply antirust paste as described above (to rotor splines (12), brake housing (40) and brake disc (44)). Replace brake disc and ensure it moves freely. Pre-assemble air brake piston and (49) and pressure plate (51) into the air brake housing. Coat all moving faces with antirust paste. Replace the brake housing assembly (40). Enter the springs (53). Centre the brake housing cover (54) and secure with screws (55). Replace motor cover (32) and secure with screws (33). Replace the air control valve and check all motor functions.

Due to the asymmetric design of the hoist the running noises and idle speeds for RH and LH rotation differ. The values quoted in the table on page 7 always refer to the pull/lifting side. Test the brake open and hold open functions when air is applied. To prevent a continual slipping of the brake linings a pressure of at least 2.6 bar must be applied.

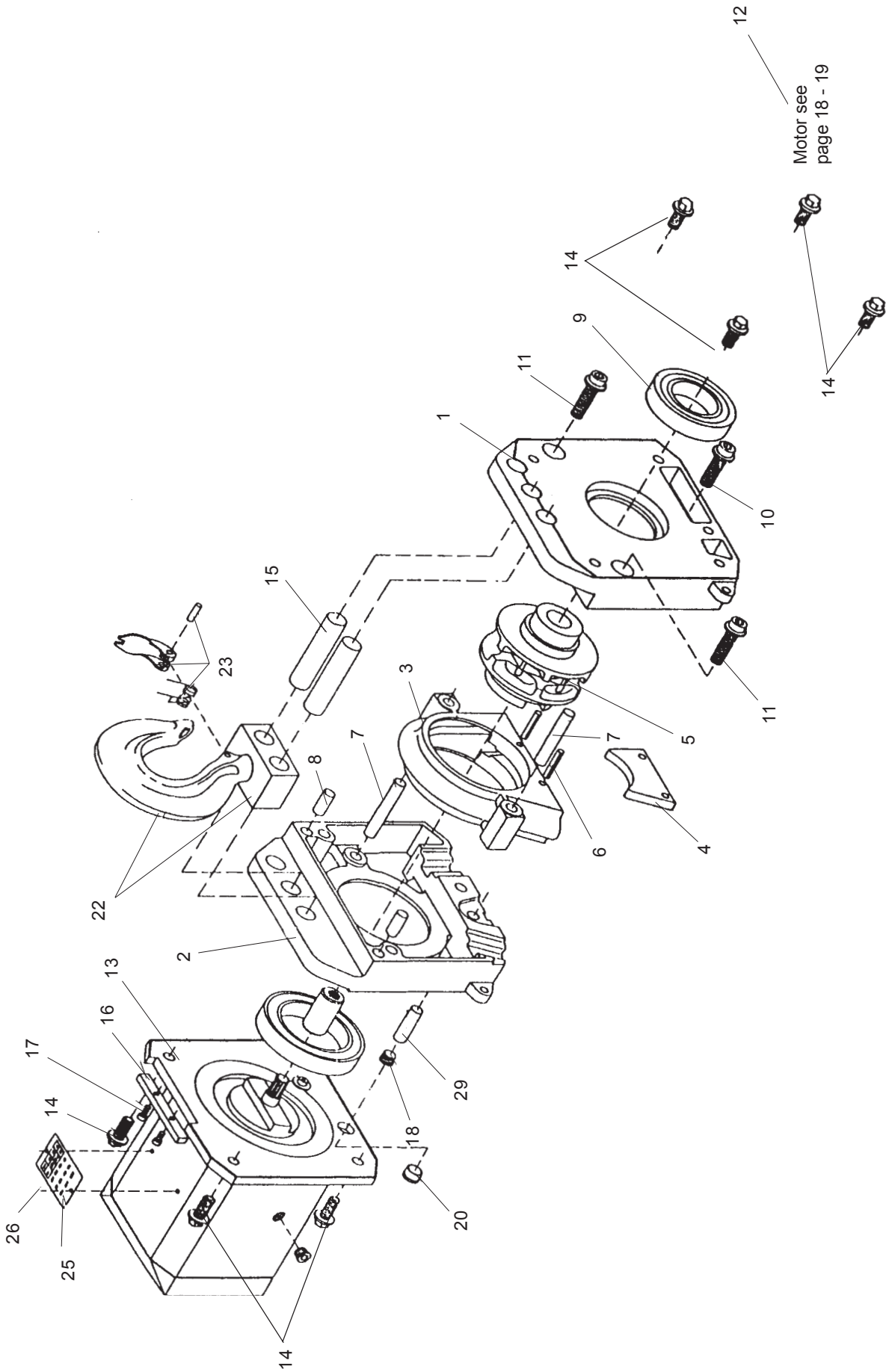

Fig. 16: Hoist body

No.	Description	Qty.	Yale-part. No.				
			CPA 20-8	CPA 30-6	CPA 40-4	CPA 50-3	CPA 60-3
1-11	Suspension unit assy.	1	0609449	0609449	0609449	0609449	0609449
1	Body half, motor side	1	0608972	0608972	0608972	0608972	0608972
2	Body half, gearbox side	1	0608974	0608974	0608974	0608974	0608974
3	Chain guide	1	0608976	0608976	0608976	0608976	0608976
4	Chain stripper	1	0608978	0608978	0608978	0608978	0608978
5	Load chain sheave	1	0609374	0609374	0609374	0609374	0609374
6	Roll pin	2	9134001	9134001	9134001	9134001	9134001
7	Pin	2	9124169	9124169	9124169	9124169	9124169
8	Pin	2	9124111	9124111	9124111	9124111	9124111
9	Bearing	1	9151106	9151106	9151106	9151106	9151106
10	Screw	1	9102253	9102253	9102253	9102253	9102253
11	Screw	2	9102254	9102254	9102254	9102254	9102254
12	Air motor	1	0850003	0850003	0850003	0850003	0850003
13	Planetary gearbox	1	0609678	0608814	0609678	0608814	0608814
14	Screw	8	9101660	9101660	9101660	9101660	9101660
15	Shaft	2	0609388	0609388	0609388	0609388	0609388
16	Locking plate	1	0609448	0609448	0609448	0609448	0609448
17	Screw	2	9102150	9102150	9102150	9102150	9102150
18	Plug	2	9110007	9110007	9110007	9110007	9110007
20	Plug	1	9192003	9192003	9192003	9192003	9192003
21	Plug	1	9192002	9192002	9192002	9192002	9192002
22-23	Suspension hook assy.	1	0609393	0609393	0609517	0609517	
23	Safety latch kit	1	0408671	0408671	0408671	0408671	
25	Nameplate	1	0800058	0800058	0800058	0800058	0800058
26	Nail	2	9128004	9128004	9128004	9128004	9128004
27	Capacity plate	1	0600002	0609696	0600001	0609511	0600212
28	Nameplate	2	0609692	0609692	0609692	0609692	0609692
29	Anchor pin	1	---	---	0608855	0608855	0608855

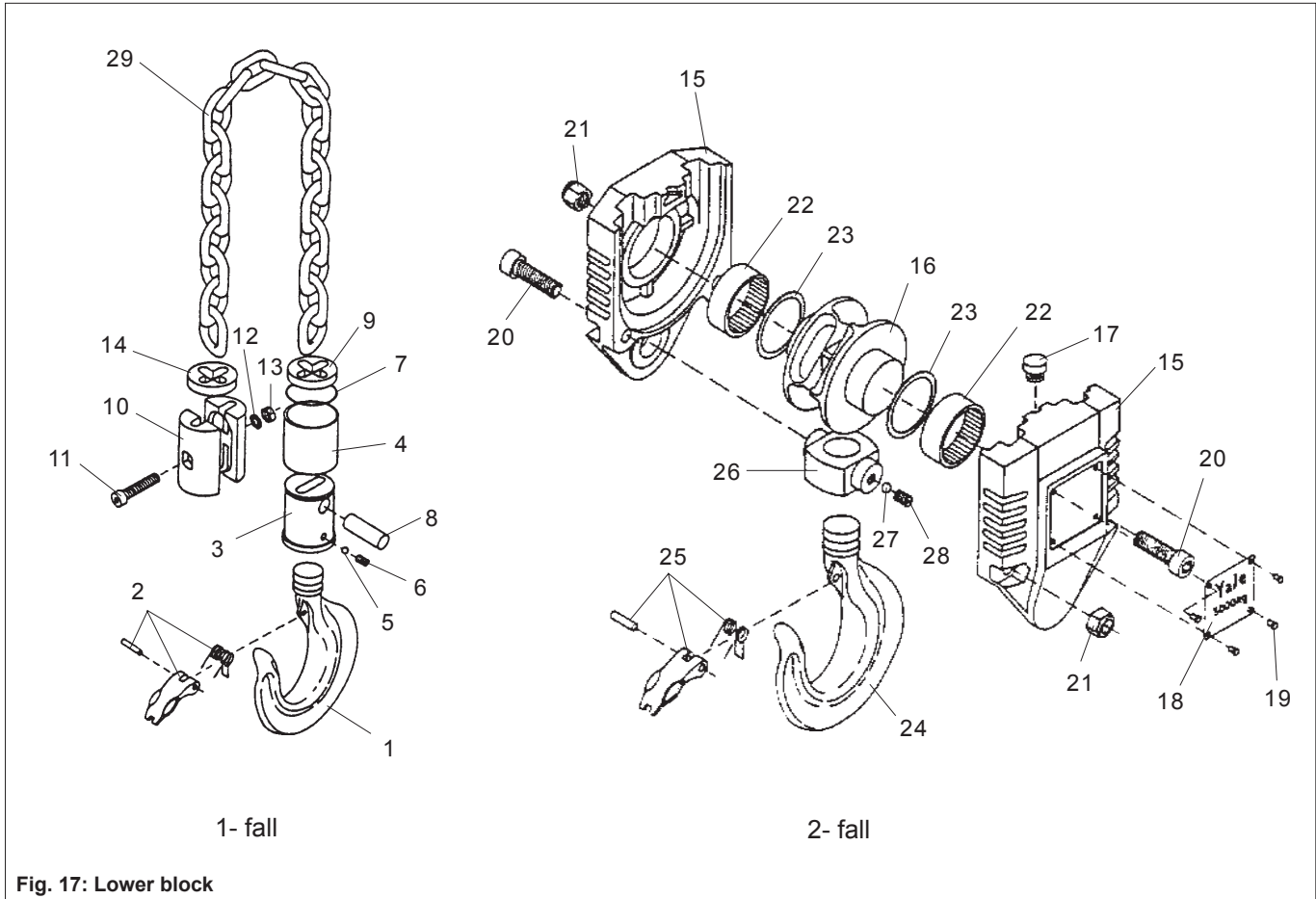

Fig. 17: Lower block

No.	Description	Qty.	Yale-Part. No.			No.	Description	Qty.	CPA 40-4
			CPA 20-8	CPA 30-6					
1-8	Lower block assy.	1	0609993	0609909		15-23	Lower block assy.	1	0609994
1-2	Hook assy.	1	0408430	0408430		15	Coupling half	2	0609495
2	Safety latch kit	1	0408671	0408671		16	Load chain sheave	1	0609505
3	Load hook coupling	1	0608851	0608851		17	Buffer	1	0601704
4	Tube	1	0600003	0609908		18	Capacity plate	2	0600001
5	Ball kit (15 pieces. á Ø5)	1	0404767	0404767		19	Nail Ø3 x 4	8	9128004
6	Set screw	1	9114030	9114030		20	Screw	2	9102053
7	Circlip	1	9139020	9139020		21	Nut	2	9115118
8	Anchor pin	1	0608855	0608855		22	Needle bearing	2	9153083
9	Buffer	1	0609734	0609734		23	Shim	2	9121218
10-14	Swivel block assy.	1	0609995	0609995		24-25	Load hook assy.	1	0408434
10	Swivel block half	2	0608867	0608867		25	Safety latch kit	1	0408672
11	Screw	1	9102019	9102019		26-28	Hook connector	1	0404850
12	Lock washer	1	9122032	9122032		27	Ball kit (16 pieces. á Ø6)	1	0404799
13	Nut	1	9115014	9115014		28	Set screw	1	9114184
14	Buffer	1	0609734	0609734		29	Chain (for all units)*		

* Quote length

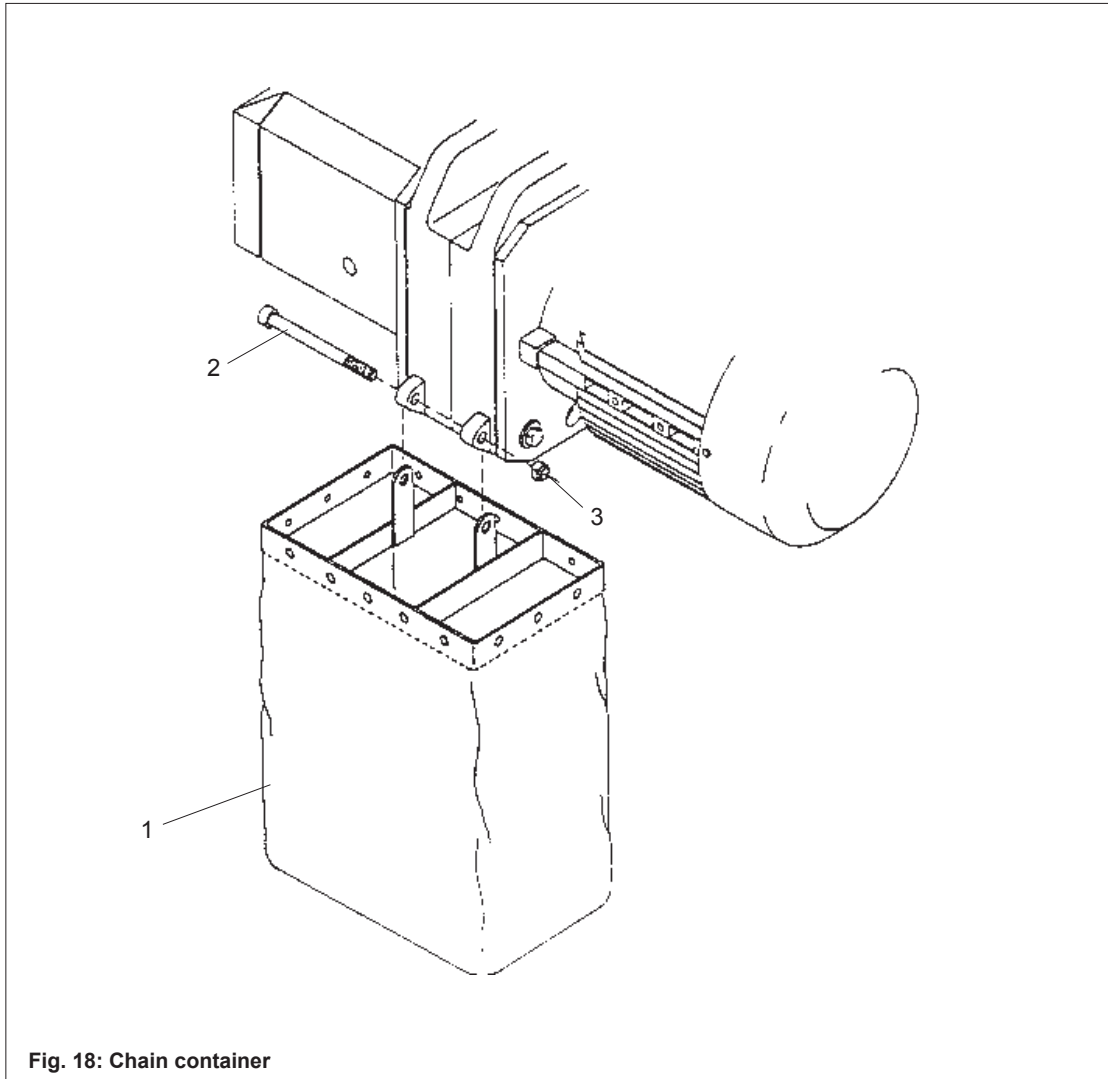

Fig. 18: Chain container

No.	Description	Qty.	Yale-Part. No.
			all units
1	Chain container assy. for 13 m chain	1	06109467
1	Chain container assy. for 21 m chain	1	06109468
2	Screw	1	9102255
3	Nut	1	9115098

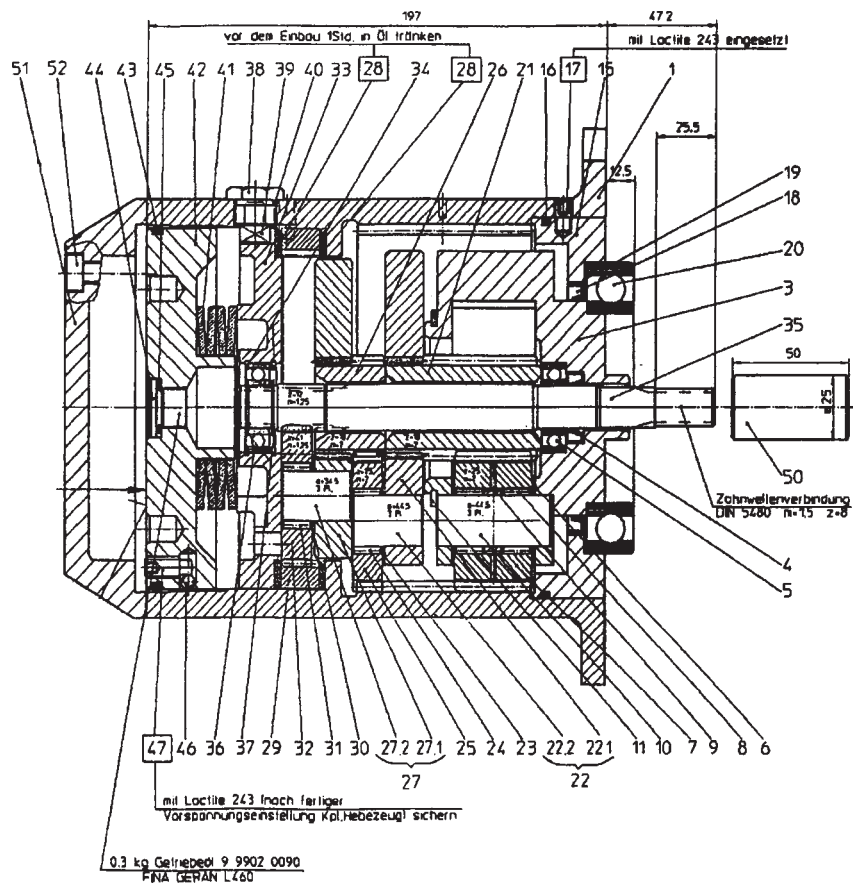

Fig. 19: Gearbox

No.	Description	Qty.	Yale-Part. No.	No.	Description	Qty.	Yale-Part. No.
			CPA 20-8 CPA 30-6 CPA 40-4 CPA 50-3 CPA 60-3				CPA 20-8 CPA 30-6 CPA 40-4 CPA 50-3 CPA 60-3
	Planetary gearbox, ass.	1	00600230	27	Planet carrier assy.	1	00600251
1	Housing	1	00600237	27.1	Washer	1	00600252
2	Ring	1	00600238	27.2	Planet shaft	3	00600253
3	Planet carrier	1	00600239	28	Brake lining	2	00600254
4	Oil seal	1	09172110	29	Annulus	1	00600255
5	Bearing	1	09150043	30	Thrust washer	3	09153043
6	Thrust washer	6	09153043	31	Needle bearing	3	09153090
7	Planet gear	3	00600240	32	Planet gear	3	00600171
8	Needle bearing	6	09153090	33	Washer	1	00600256
9	Spacer ring	3	00600241	34	Retaining ring	2	09130034
10	Planet shaft	3	00600242	35	Shaft	1	00600257
11	Retaining ring	1	09129070	36	Bearing	1	09150043
13	Ring	1	00600243	37	Retaining ring	2	09129029
14	Retaining ring	1	09129071	38	Lock screw	1	00600258
15	Ring	1	00600244	39	Pin	1	00600259
16	O-Ring	1	09171352	40	O-Ring	1	09171169
17	Set screw	1	09114134	41	Cup spring	4	09120041
18	Oil seal	1	09172112	42	Adjuster	1	00600260
19	Shim	1	09121234	43	O-Ring	1	09171170
20	Bearing	1	09151101	44	Plug	1	09110052
21	Sun wheel	1	00600245	45	Gasket	1	09179004
22	Planet carrier assy.	1	00600246	46	Ball	1	09159011
22.1	Washer	1	00600247	47	Set screw	1	09114136
22.2	Planet shaft	3	00600248	48	Shim	1	09121056
23	Thrust washer	3	09153043	50	Coupling	1	00608879
24	Needle bearing	3	09153090	51	Cover	1	00600262
25	Planet gear	3	00600249	52	Screw	4	09102019
26	Sun wheel	1	00600250				

Attention: When ordering spare parts please indicate item number and manufacturing year of the unit.

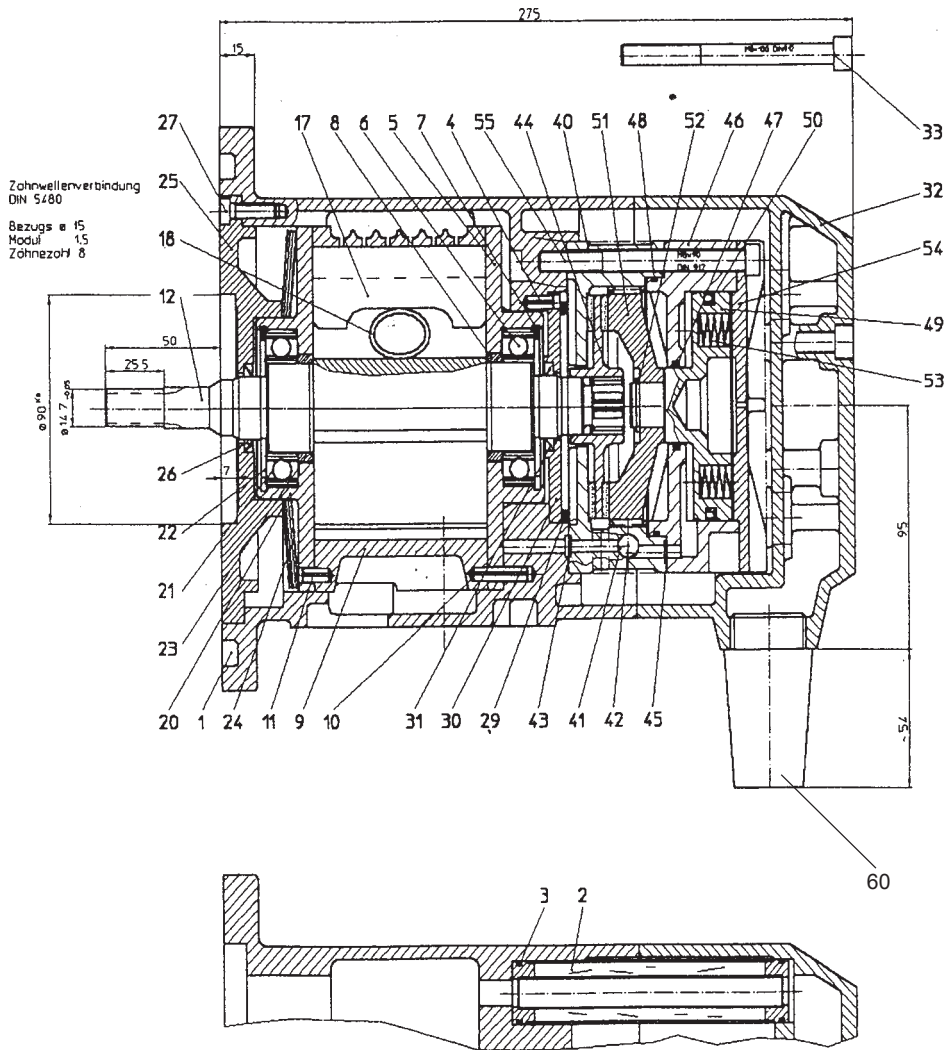

Fig. 20: Motor

No	Description	Qty.	Yale-Part. No		Description	Qty.	Yale-Part. No	
				for all units				for all units
	Motor assy.	1	00850003	31	Oil seal	1	00800042	
1	Housing	1	00800013	32	Cover	1	00800024	
2	Silencer assy.	6	00800014	33	Screw	4	09102268	
3	O-Ring	12	09171115	40-55	Disc brake assy.	1	00800025	
4	Roll pin	1	09134048	40	Brake housing assy.	1	00800026	
5	Seal plate	1	00800015	41	Control piston f. brake air	1	00800027	
6	Bearing	1	09151119	42	Spacer screw	2	00800043	
7	Retaining ring	1	09130001	43	O-Ring	2	09171165	
8	Spacer ring	1	00800016	44	Brake disc assy.	1	00800028	
9	Motor cylinder asymmetric	1	00800017	45	O-Ring	1	09171165	
10	Roll pin	1	09134052	46	Air brake housing	1	00800039	
11	Roll pin	1	09134048	47	Quad-Ring	1	00800044	
12	Rotor	1	00800018	48	O-Ring	1	09171166	
17	Vane	7	00800019	49	Brake air piston	1	00800030	
18	O-Ring	7	09171163	50	Seal ring	1	00800045	
20	Seal plate	1	00800020	51	Pressure plate	1	00800031	
21	Bearing	1	09151119	52	Retaining ring	1	09129024	
22	Retaining ring	1	09130001	53	Spring	10	00800046	
23	Spacer ring	1	00800016	54	Cover	1	00800032	
24	Cup spring	1	00800041	55	Screw	4	09102110	
25	Cover	1	00800022	60	Sinter metal silencer	2	00800047	
26	Oil seal	1	00800042					
27	Screw	6	09102040					
29	O-Ring	1	09171164					
30	Seal plate	1	00800023					

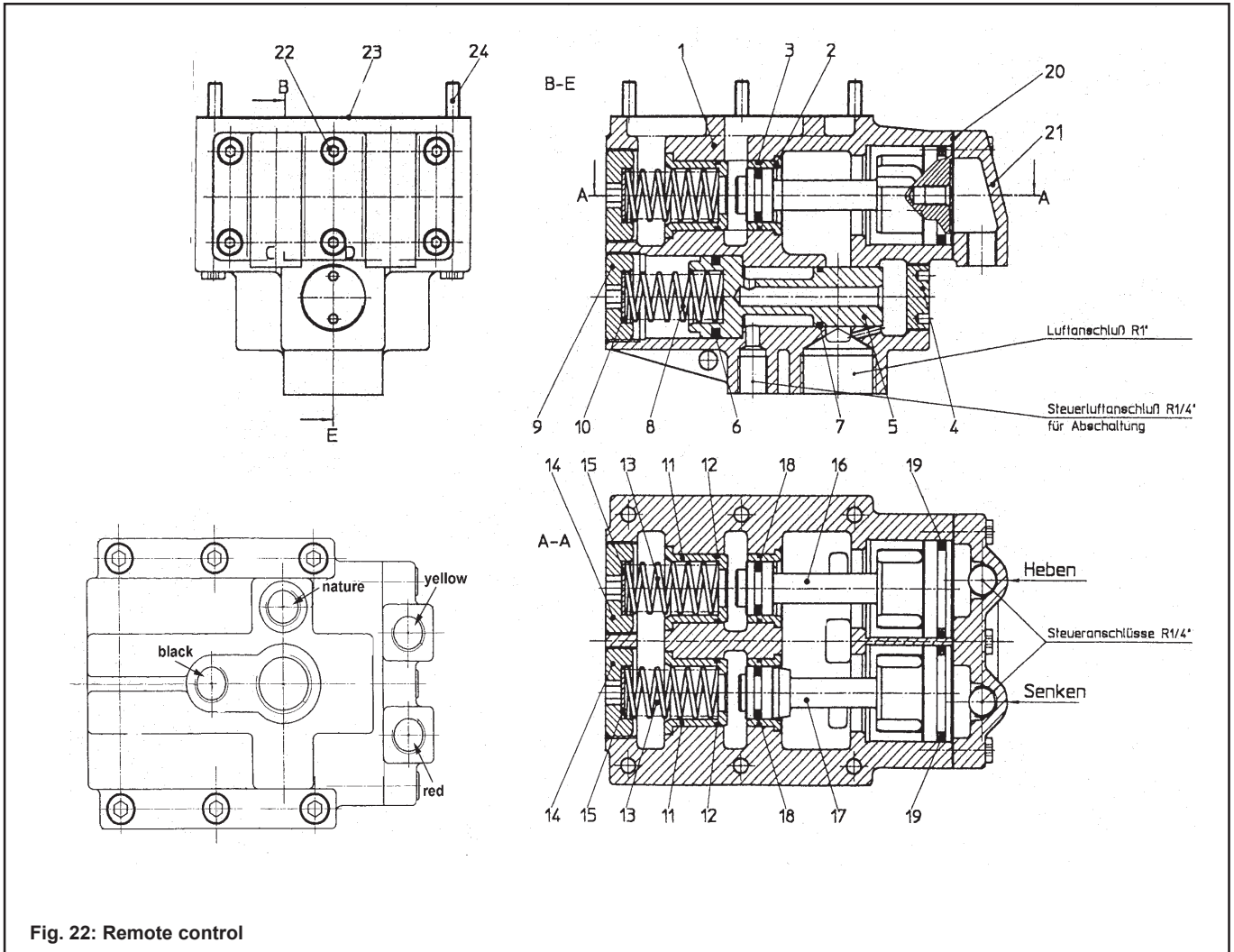

Fig. 22: Remote control

No	Description	Qty.	Yale-Part. No	Description	Qty.	Yale-Part. No	
			for all units			for all units	
	Remote control assy.	1	08600003	13	Spring	2	00800053
1	Control valve assy.	1	00800033	14	Adjusting screw	2	00800051
2	Guide bushing	2	00800034	15	Seal washer	2	00800054
3	O-Ring	2	09171167	16	Control piston assy. (lift)	1	00800037
4	Cover	1	00800048	17	Control piston assy. (lower)	1	00800038
5	Switch piston	1	00800035	18	Glyd Ring assy.	2	00800055
6	Pneum. Lip ring	1	00800049	19	Pneum. Lip ring	2	00800056
7	O-Ring	1	09171168	20	Seal	1	00800057
8	Spring	1	00800050	21	Connection plate	1	00800039
9	Adjusting screw	1	00800051	22	Screw	6	09102065
10	Seal washer	1	00800052	23	Seal	1	00800040
11	Bushing	2	00800036	24	Screw	6	09102015
12	O-Ring	2	09171167				



Abb. 24: Button control (2 way)

No	Description	Qty.	Yale-Part. No.		Description	Qty.	Yale-Part. No.	
			for all units				for all units	
	Button control assy. (2 way)	1	08600001	9	O-Ring	2	09171174	
1	Button control -housing assy.	1	00800076	10	Button, red	1	00800081	
2	Valve pusher 2	1	00800077	11	Spring compressor	1	00800082	
3	Valve pusher 1	1	00800078	12	Stop screw	1	00800083	
4	Retaining ring	2	09130059	20	Ball	1	09159016	
5	Ball	2	09159019	21	Valve screw	1	00800084	
6	O-Ring	2	09171173	22	O-Ring	1	09171172	
7	Plug	2	00800079	23	Valve pin	1	00800085	
8	Switch piston	1	00800080	24	Carrier pin	1	00800086	

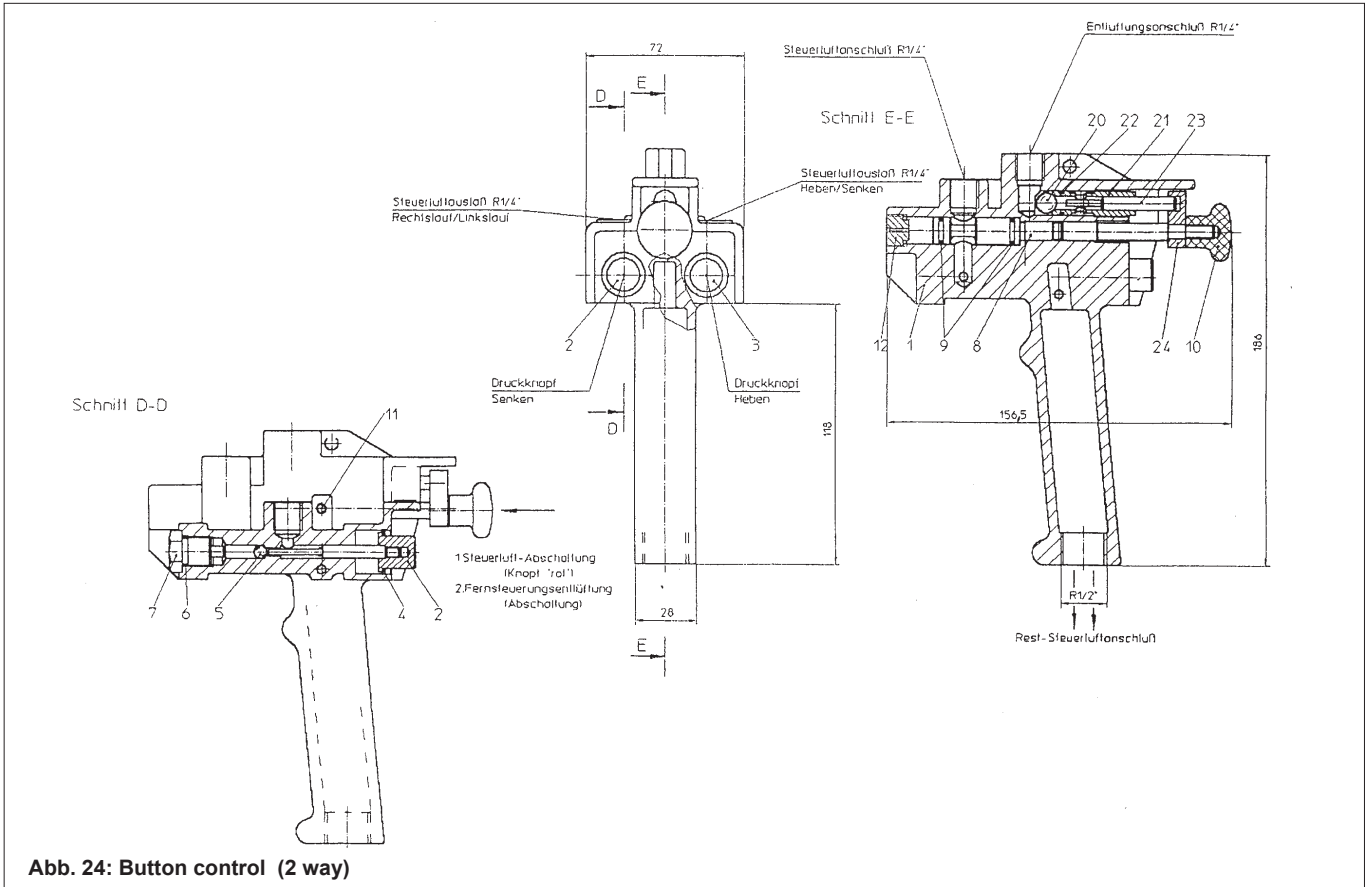
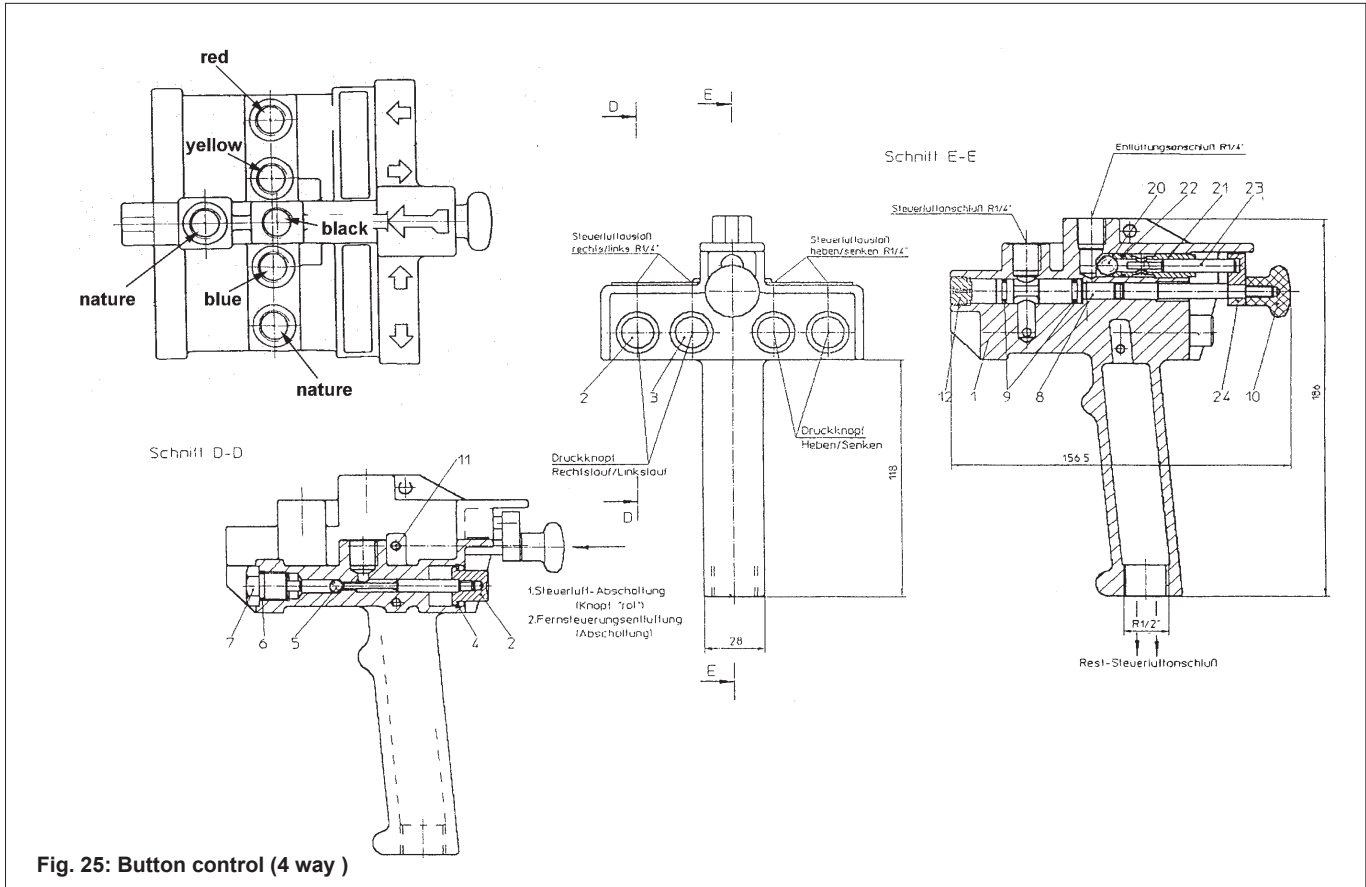

Fig. 25: Button control (4 way)

No	Description	Qty.	Yale-Part. No.		Description	Qty	Yale-Part. No.	
			for all units				for all units	
	Button control assy. (4 way)	1	08600002		9	2	09171174	
1	Button control-housing assy.	1	00800087		10	1	00800081	
2	Valve pusher 2	2	00800077		11	1	00800082	
3	Valve pusher 1	2	00800078		12	1	00800083	
4	Retaining ring	4	09130059		20	1	09159016	
5	Ball	4	09159019		21	1	00800084	
6	O-Ring	4	09171173		22	1	09171172	
7	Plug	4	00800079		23	1	00800085	
8	Switch piston	1	00800080		24	1	00800086	

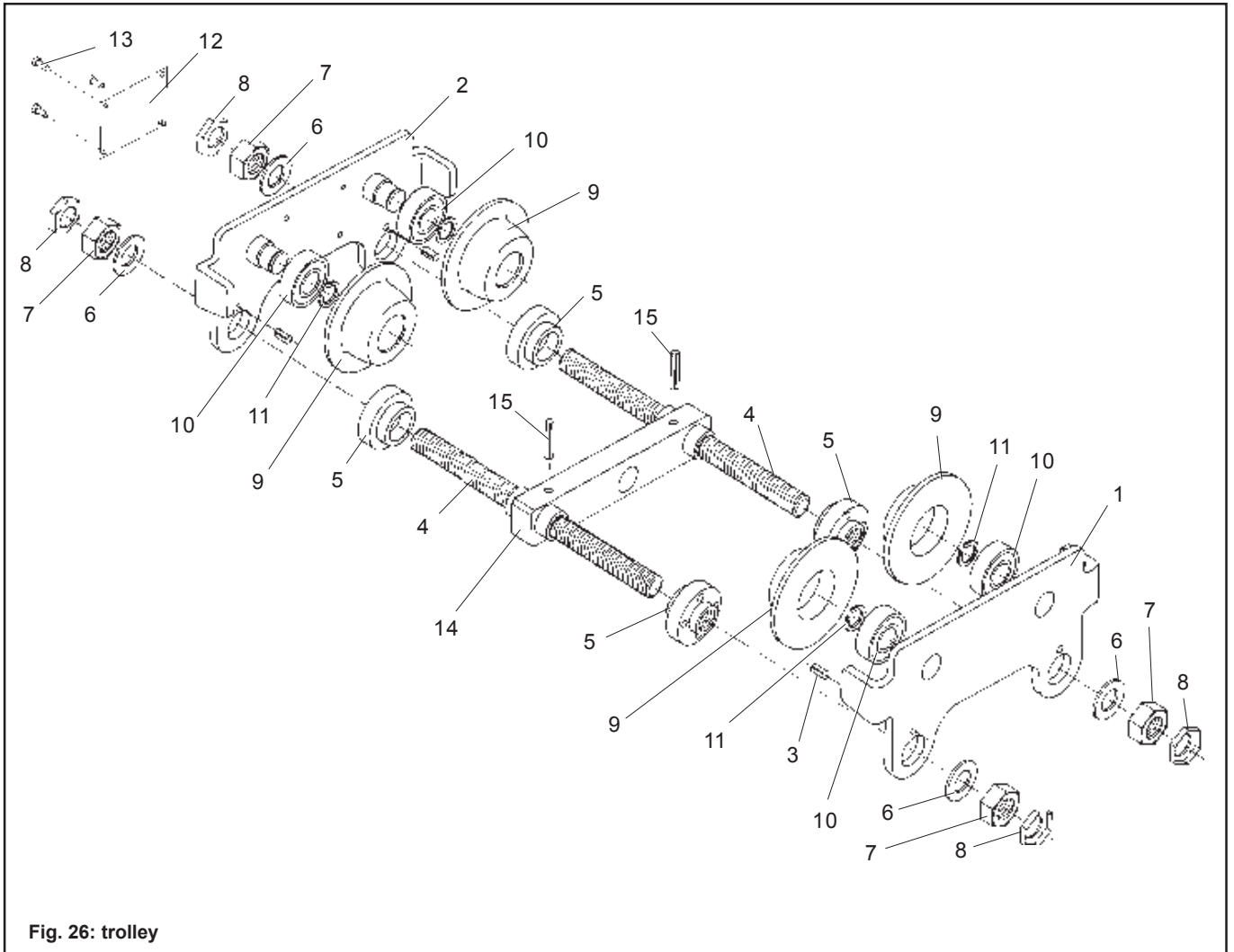

Fig. 26: trolley

No	Description	Qty.	Yale-Part. No.	Description	Qty.	Yale-Part. No.	
			for all units			for all units	
1	Sideplate	1	0559163	8	Locknut	4	9115155
2	Sideplate	1	0559167	9	Roller	4	0508210
3	Roll pin	4	9134120	10	Bearing	8	9151079
4	Traverse beam width A	2	0559169	11	Retaining ring	4	9129003
4	beam width B	2	0559170	12	Nameplate	1	0559869
5	Round nut	4	0559168	13	Nail	4	9128004
6	Washer	4	9121213	14	Centre traverse	1	0559353
7	Nut	4	9115156	15	Roll pin	2	9134002

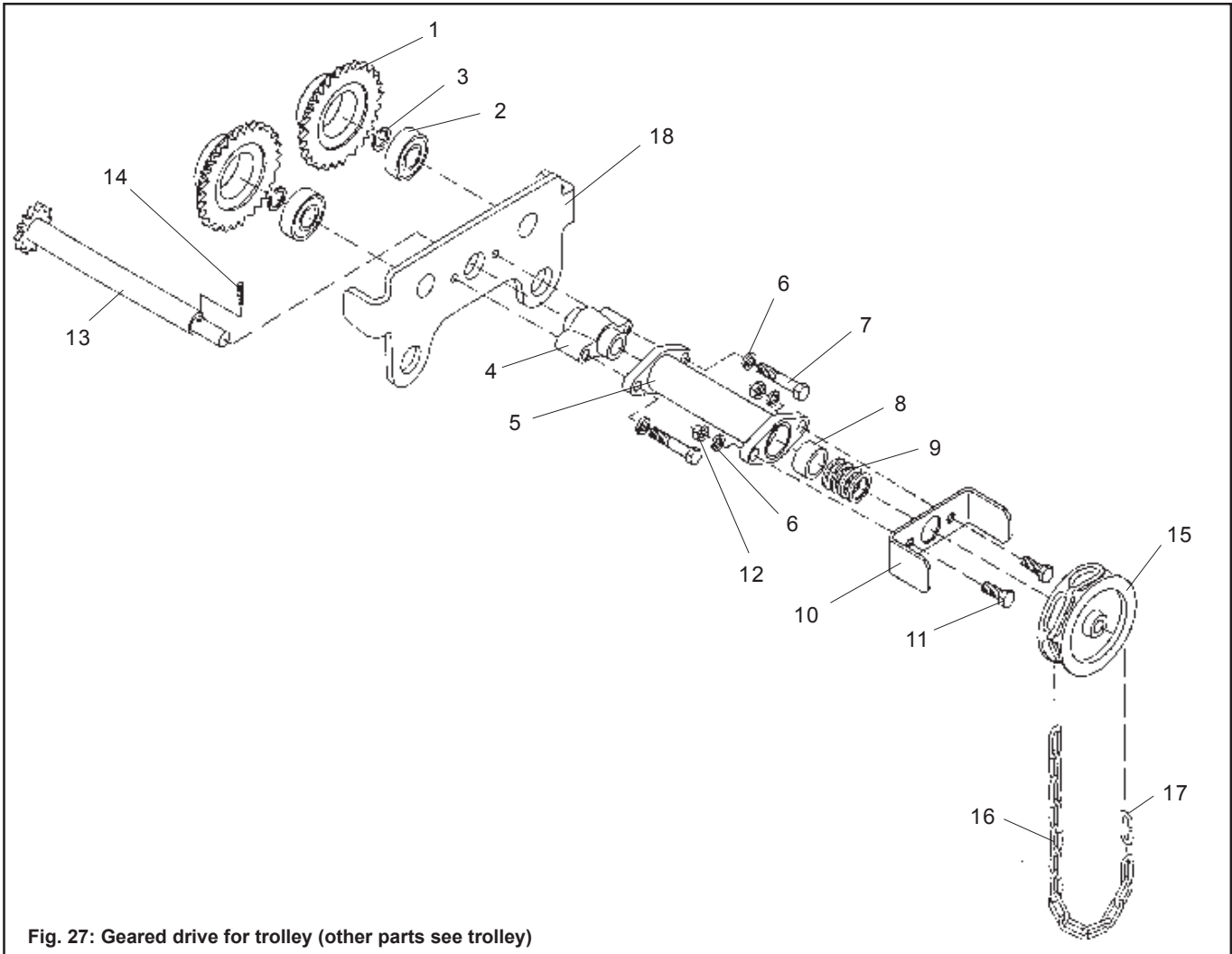

Fig. 27: Geared drive for trolley (other parts see trolley)

No	Description	Qty.	Yale-Part. No.	Description	Qty.	Yale-Part. No.	
			for all units			for all units	
1	Roller, geared	2	0508214	10	Chain guide	1	0558062
2	Bearing	8	9151079	11	Screw	2	9101014
3	Retaining ring	4	9129003	12	Nut	2	9115148
4	Mounting	1	0508229	13	Drive shaft	1	0710029
5	Guide	1	0710030	14	Roll pin	1	9134052
6	Lockwasher	4	9122016	15	Hand chain sheave	1	0558061
7	Screw	2	9101050	16	Hand chain *		4307654
8	Bushing	1	0102503	17	Connecting link	1	0404733
9	Shim	4	9121205	18	Sideplate	1	0559165

*Quote length

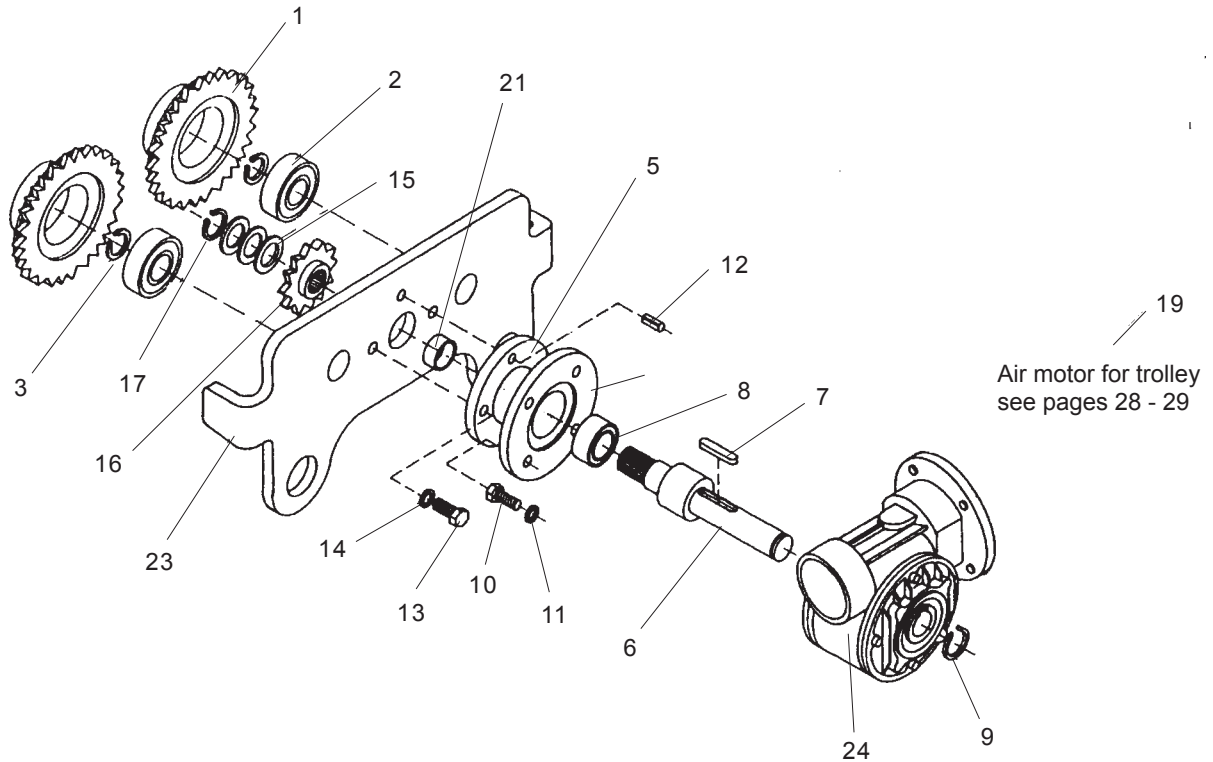

Fig. 28: Air motor for trolley (other parts see trolley)

No	Description	Qty.	Yale-Part. No.	Description	Qty.	Yale-part. No.	
			for all units			for all units	
1	Roller, geared	2	0508214	13	Screw	2	9101014
2	Bearing	8	9151079	14	Lockwasher	2	9122004
3	Retaining ring	4	9129003	15	Key	7	9121215
4	Worm gearbox	1	0719764	16	Pinion	1	0719373
5	Flange	1	0719371	17	Retaining ring	1	9123038
6	Drive shaft	1	0719372	18	Connection	1	9184082
7	Key	1	9131072	19	Air motor	1	00810001
8	Needle bearing	1	9153077	20	Reducer	1	0719868
9	Retaining ring	1	9129016	21	Bushing	1	0719870
10	Screw	4	9101170	22	Screw	4	9101439
11	Lockwasher	4	9122003	23	Sideplate	1	0559165
12	Roll pin	1	9134080	24	Worm gearbox	1	00710033



No	Description	Qty.	Yale-Part. No	Description	Qty	Yale-Part. No	
			for all units			for all units	
	Air drive	1	00810001	21	Screw	6	09120265
1	Housing	1	00800124	22	Cover	1	00800129
2	Air entry	1	00800125	23	Screw	4	09102248
3	Silencer material	1	00800089	24	Sinter metal silencer	1	00800047
4	Plug	2	00800090	30	Flange housing	1	00800130
5	Seal plate	1	00800091	31	Bearing	1	09151122
6	Bearing	1	09151086	32	Retaining ring	1	09130034
7	Retaining ring	1	09130045	33	Drive shaft	1	00800191
8	Spacer ring	1	00800092	34	Retaining ring	1	09129029
9	Motor cylinder	1	00800126	35	Key and sleeve	1	00719868
10	Roll pin	1	09134077	36	Coupling	1	00800132
11	Roll pin	1	09134042	37	Bearing	1	09150040
12	Rotor	1	00800094	38	Washer	1	00800133
13	Vane	5	00800127	39	Lockwasher	4	09122031
14	O-Ring	5	09171176	40	Screw	4	09102169
15	Seal plate	1	00800091				
16	Bearing	1	09151086				
17	Retaining ring	1	09130045				
18	Spacer ring	1	00800128				
19	Cup spring	1	00800098				
20	Cover	1	00800099				

EG-DECLARATION OF CONFORMITY

In accordance with EG-Machinery Directive 98/37/EG. Appendix II A.

We,

Yale Industrial Products GmbH
D- 42549 Velbert, Am Lindenkamp 31

hereby declare, that the design, construction and commercialised execution of the below mentioned machine complies with the essential health and safety requirements of the EC Machinery Directive. The validity of this declaration will cease in case of any modification or supplement not being agreed with us previously. Furthermore, validity of this declaration will cease in case that the machine will not be operated correctly and in accordance to the operating instructions and/or not be inspected regularly.

Machine description:	Pneumatic chain hoist CPA Mod. CPA20-8, CPA30-6, Mod. CPA40-4, CPA50-3, Mod. CPA 60-3 Capacity 2000 - 6000 kg
Machine type:	Pneumatic chain hoist
Serial number:	from manufacturing year 01/00 (serial numbers for the individual capacities/models are registered in the production book with the remark CE-sign)
Relevant EC Directives:	EG-Machinery Directive (98/37/EWG)
Transposed harmonised Standards in particular:	EN 292, part 1 (safety of machines) EN 292, Part 2 (safety of machines) EN 349 (safety of machines) EN 818, part 1 (round link chains) prEN 818, part 4 (round link chains)
Transposed (either complete or in extracts) national standards and technical specifications in particular:	FEM 9.671; DIN 5684 (Lastketten) FEM 9.682 (Hubmotoren) FEM 9.755 (Betriebsdauer) FEM 9.511 (classification) DIN 15018 (Krane) DIN 15400 (Lasthaken für Hebezeug) DIN 15404 (Lasthaken für Hebezeug) VBG 8 (Winden, Hub- und Zuggeräte) VBG 9 (Krane) VBG 9.a (Lastaufnahmemittel) ZH 1/27 (Prüfung von Kranen) ZH1/25 (Prüfung von Hubgeräten)
Quality assurance:	DIN/ISO 9001 (Certificate Registration No.: 150)

Date/Manufacturer's authorised signature:

2001-03-05

Identification of the signee:

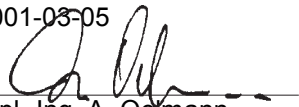
 Dipl.-Ing. A. Oelmann
 Manager Quality assurance