

HR-1200 Side Pull Hoist Rings

Load Rated

SELBY ENGINEERING & LIFTING SAFETY LTD.
 Lifting Equipment and Height Safety Specialists
 www.liftingsafety.co.uk sales@liftingsafety.co.uk
 Tel: +44 (0) 1977 684 600 Fax: +44 (0) 1977 685 300

HR-1200



- Wide range of capacities available:
 - 650 lbs. to 29,000 lbs.
 - Metric sizes from 0.3 tonnes to 13 tonnes.
- Body components are Alloy Steel - Quenched and Tempered.
- Rated at 100% of Working Load Limit for angles up to 90 degrees.
- Each product is stamped with a Product Identification Code (PIC), for material traceability, along with a Working Load Limit, and the name Crosby or "CG".
- Hoist Ring body is furnished with Yellow Chromate finish for improved corrosion resistance.
- Utilize standard Crosby Red Pin® Shackles to connect to wire rope or synthetic slings. (sold separately)
- Multiple bolt lengths available to meet specific application requirements.
- Individually Proof Tested to 2-1/2 times Working Load Limit.
- All sizes are RFID EQUIPPED.

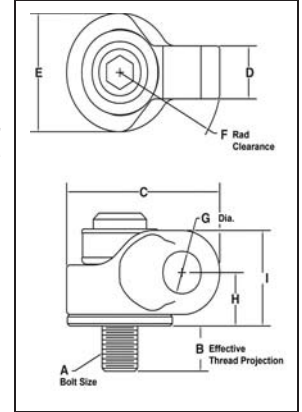

HR-1200 UNC Side Pull Hoist Rings

Weight Each (lbs.)	Working Load Limit (lbs.)*	HR-1200 Stock No.	Hoist Ring Bolt Torque (Ft.Lbs.)	(A) Bolt Size	(B) Eff. Thread Proj. (in.)	Dimensions (in.)							Recommended Shackles			
						C	D	E	F	Dia. G	H	I	Red Pin® Shackles 209,210,213, 215,2130,2150		Red Pin Web Shackles S-281	
													Nominal Size (in.)	WLL (t)	Web Size (in.)	WLL (Tons)
.35	650	1067700	7	5/16-18x1.50	.59	1.93	.72	1.00	1.56	.80	.85	1.25	1/2, 5/8	2, 3-1/4	2	3-1/4
.36	800	1067704	12	3/8-16x1.50	.59	1.93	.72	1.00	1.56	.80	.85	1.25	1/2, 5/8	2, 3-1/4	2	3-1/4
1.4	2000	1067708	28	1/2-13x2.00	.71	2.97	.97	2.00	2.13	.93	1.07	1.79	5/8, 3/4	3-1/4, 4-3/4	2, 1.5	3-1/4, 4-1/2
1.4	2000	1067712	28	1/2-13x2.50	1.21	2.97	.97	2.00	2.13	.93	1.07	1.79	5/8, 3/4	3-1/4, 4-3/4	2, 1.5	3-1/4, 4-1/2
1.5	3000	1067716	60	5/8-11x2.00	.71	2.97	.97	2.00	2.13	.93	1.07	1.79	5/8, 3/4	3-1/4, 4-3/4	2, 1.5	3-1/4, 4-1/2
1.5	3000	1067720	60	5/8-11x2.75	1.46	2.97	.97	2.00	2.13	.93	1.07	1.79	5/8, 3/4	3-1/4, 4-3/4	2, 1.5	3-1/4, 4-1/2
4.5	5000	1067724	100	3/4-10x2.75	.90	4.32	1.34	3.00	3.00	1.07	1.35	2.42	7/8	6-1/2	2	6-1/4
4.6	5000	1067728	100	3/4-10x3.50	1.65	4.32	1.34	3.00	3.00	1.07	1.35	2.42	7/8	6-1/2	2	6-1/4
4.6	6500	1067732	160	7/8-9x2.75	.90	4.32	1.34	3.00	3.00	1.07	1.35	2.42	7/8	6-1/2	2	6-1/4
4.8	6500	1067736	160	7/8-9x3.50	1.65	4.32	1.34	3.00	3.00	1.07	1.35	2.42	7/8	6-1/2	2	6-1/4
4.8	8000	1067740	230	1-8x3.00	1.15	4.32	1.34	3.00	3.00	1.07	1.35	2.42	7/8	6-1/2	2	6-1/4
5.0	8000	1067744	230	1-8x4.00	2.15	4.32	1.34	3.00	3.00	1.07	1.35	2.42	7/8	6-1/2	2	6-1/4
10.2	14000	1067748	470	1-1/4-7x4.5	2.22	5.59	1.57	3.75	3.91	1.47	1.92	3.42	1, 1-1/8, 1-1/4	8-1/2, 9-1/2, 12	3	8-1/2
23.5	17200	1067756	800	1-1/2-6x6.5	2.98	7.31	2.06	4.75	5.19	2.11	2.41	4.29	1-3/8, 1-1/2, 1-3/4	13-1/2, 17, 25	-	-
25.3	29000	1067764	1100	2-4.5x6.5	2.98	7.31	2.06	4.75	5.19	2.11	2.41	4.29	1-3/8, 1-1/2, 1-3/4	13-1/2, 17, 25	-	-

* Ultimate Load is 5 times the Working Load Limit.

HR-1200M Metric Side Pull Hoist Rings

Weight Each (kg)	Working Load Limit (kg)*	HR1200M Stock No.	Hoist Ring Bolt Torque (Nm)	(A) Bolt Size	(B) Eff. Thread Proj. (mm)	Dimensions (mm)							Recommended Shackles			
						C	D	E	F	G	H	I	Red Pin Shackles 209,210,213, 215,2130,2150		Red Pin Web Shackles S-281	
													Nominal Size (in.)	WLL (t)	Web Size (in.)	WLL (Tons)
.18	300	1067803	10	M8x1.25x40	16.9	49.0	18.3	25.4	39.6	20.3	21.6	36.3	1/2, 5/8	2, 3-1/4	2	3-1/4
.18	400	1067807	16	M10x1.50x40	16.9	49.0	18.3	25.4	39.6	20.3	21.6	36.3	1/2, 5/8	2, 3-1/4	2	3-1/4
.63	1000	1067811	38	M12x1.75x50	17.2	75.4	24.6	50.8	54.1	23.6	27.2	45.5	5/8, 3/4	3-1/4, 4-3/4	2, 1.5	3-1/4, 4-1/2
.68	1400	1067815	81	M16x2.0x60	27.2	75.4	24.6	50.8	54.1	23.6	27.2	45.5	5/8, 3/4	3-1/4, 4-3/4	2, 1.5	3-1/4, 4-1/2
2.0	2250	1067823	136	M20x2.5x75	28.1	110	34.0	76.2	76.2	27.2	34.4	61.5	7/8	6-1/2	2	6-1/4
2.2	3500	1067827	312	M24x3.0x80	33.1	110	34.0	76.2	76.2	27.2	34.4	61.5	7/8	6-1/2	2	6-1/4
4.5	6250	1067831	637	M30x3.5x120	65.1	142	39.9	95.3	99.3	37.3	48.8	86.9	1, 1-1/8, 1-1/4	8-1/2, 9-1/2, 12	3	8-1/2
10.4	7750	1067835	1005	M36x4.0x150	60.6	186	52.3	121	132	53.6	61.2	109	1-3/8, 1-1/2, 1-3/4	13-1/2, 17, 25	-	-
10.7	10000	1067839	1005	M42x4.5x160	70.6	186	52.3	121	132	53.6	61.2	109	1-3/8, 1-1/2, 1-3/4	13-1/2, 17, 25	-	-
11.0	13000	1067843	1350	M48x5.0x160	70.6	186	52.3	121	132	53.6	61.2	109	1-3/8, 1-1/2, 1-3/4	13-1/2, 17, 25	-	-

* Ultimate Load is 5 times the Working Load Limit.