

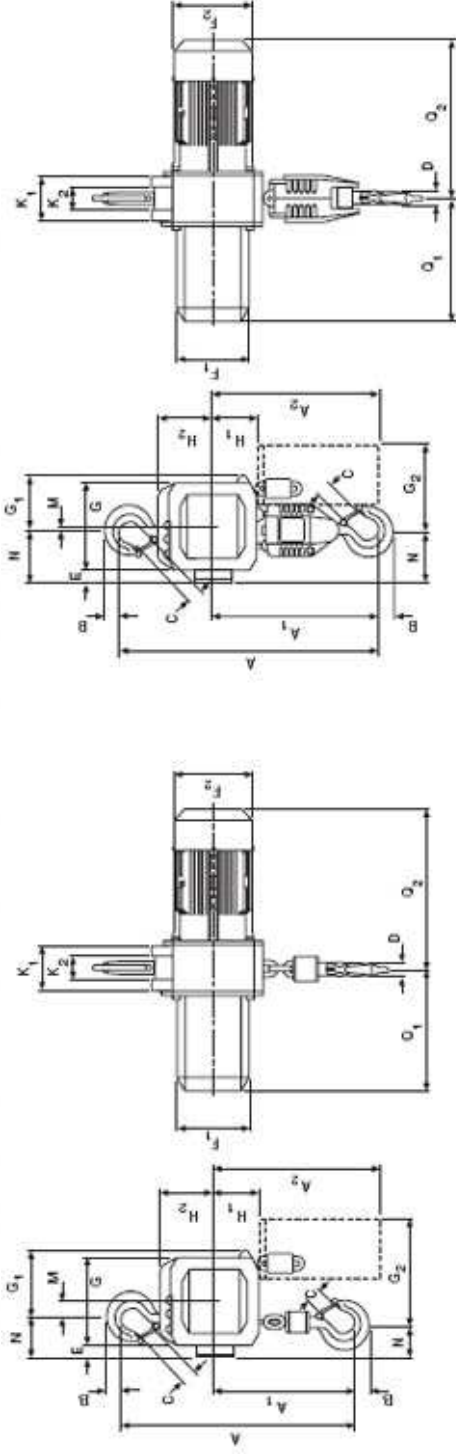

# SELBY ENGINEERING & LIFTING SAFETY LTD.

*Lifting Equipment and Height Safety Specialists*  
[www.liftingsafety.co.uk](http://www.liftingsafety.co.uk) Email: [sales@liftingsafety.co.uk](mailto:sales@liftingsafety.co.uk)

Tel: (01977) 684600 Fax: (01977) 685300



**Model CPE with suspension hook, single fall**

1.600 - 3.000 kg

**Model CPE with suspension hook, double fall**

3.200 - 5.000 kg

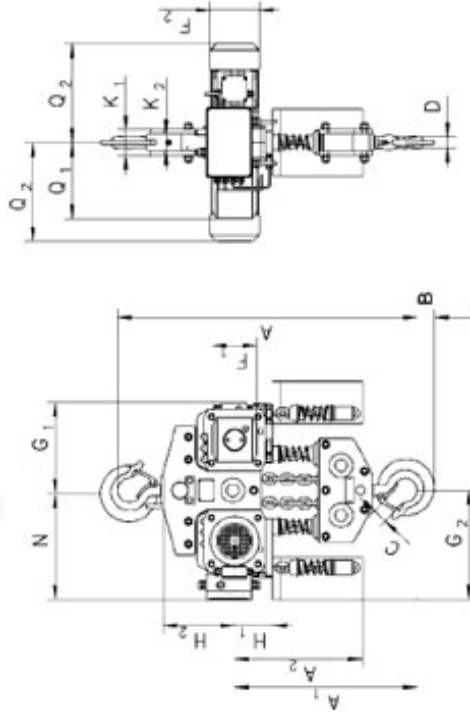

**Model CPE 100-2 with suspension hook**

10,000 kg

3 LINCOLN WAY, SHERBURN-IN-ELMET, LEEDS, WEST YORKSHIRE LS25 6PJ  
 Registered in England No. 3013233. V.A.T. Reg No. 599 2962 66  
[www.liftingsafety.co.uk](http://www.liftingsafety.co.uk) Email: [sales@liftingsafety.co.uk](mailto:sales@liftingsafety.co.uk)





**SELBY ENGINEERING & LIFTING SAFETY LTD.**

*Lifting Equipment and Height Safety Specialists*  
[www.liftingsafety.co.uk](http://www.liftingsafety.co.uk) Email: [sales@liftingsafety.co.uk](mailto:sales@liftingsafety.co.uk)

Tel: (01977) 684600 Fax: (01977) 685300

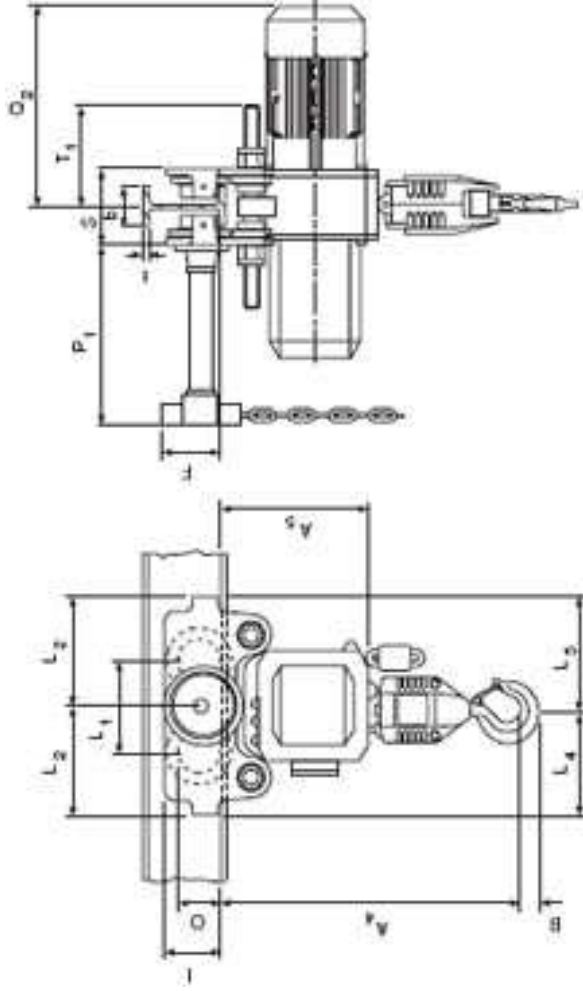

**Model CPE**  
**with integral push or geared trolley**

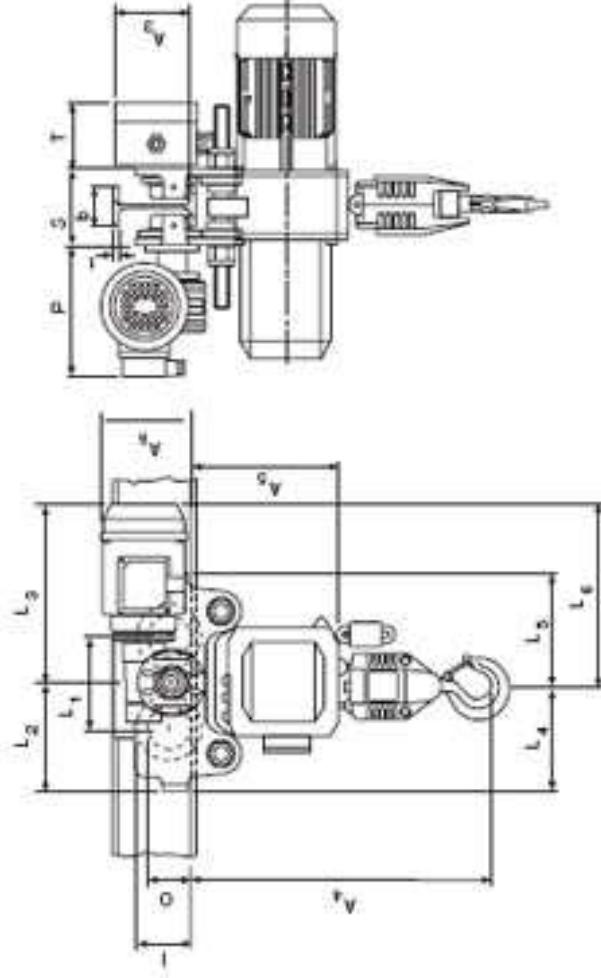

**Model CPE**  
**with integral electric trolley**

3 LINCOLN WAY, SHERBURN-IN-ELMET, LEEDS, WEST YORKSHIRE LS25 6PJ  
 Registered in England No. 3013233. V.A.T. Reg No. 599 2962 66  
[www.liftingsafety.co.uk](http://www.liftingsafety.co.uk) Email: [sales@liftingsafety.co.uk](mailto:sales@liftingsafety.co.uk)





# SELBY ENGINEERING & LIFTING SAFETY LTD.

*Lifting Equipment and Height Safety Specialists*  
www.liftingsafety.co.uk Email: sales@liftingsafety.co.uk  
Tel: (01977) 684600 Fax: (01977) 685300

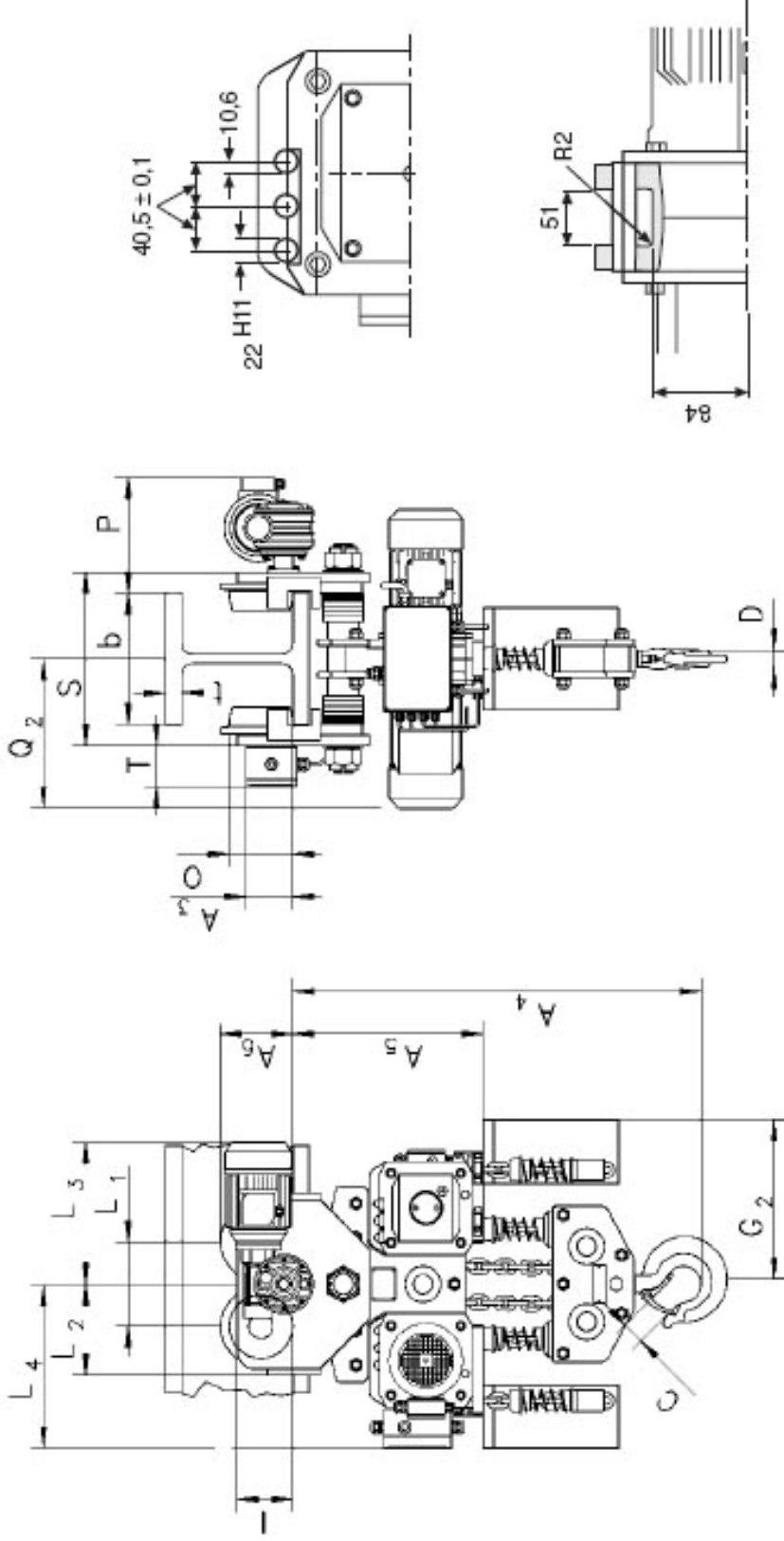

## Model CPE 100-2, with integral electric trolley

10.000 kg



3 LINCOLN WAY, SHERBURN-IN-ELMET, LEEDS, WEST YORKSHIRE LS25 6PJ  
Registered in England No. 3013233. V.A.T. Reg No. 599 2962 66  
www.liftingsafety.co.uk Email: sales@liftingsafety.co.uk



# SELBY ENGINEERING & LIFTING SAFETY LTD.

Lifting Equipment and Height Safety Specialists  
[www.liftingsafety.co.uk](http://www.liftingsafety.co.uk) Email: [sales@liftingsafety.co.uk](mailto:sales@liftingsafety.co.uk)

Tel: (01977) 684600 Fax: (01977) 685300

Dimension	A	A1	A2 (13 m)	A2 (21 m)	B	C	D	E	F1	F2	G	G1	G2 (13 m)	G2 (21 m)	H1	H2	K1	K2	M	N	Q1	Q2 (CPE)	Q2 (CPEF)
CPE / CPEF 16-8	516	286	430	530	35	37	24	24	160	178	220	180	257	277	110	135	100	51	50,0	84	280	362	417
CPE / CPEF 20-8	516	286	430	530	35	37	24	24	160	178	220	180	257	277	110	135	100	51	50,0	84	280	362	417
CPE / CPEF 25-5	516	286	430	530	35	37	24	24	160	178	220	180	257	277	110	135	100	51	50,0	84	280	362	417
CPE / CPEF 30-5	516	286	430	530	35	37	24	24	160	178	220	180	257	277	110	135	100	51	50,0	84	280	362	417
CPE / CPEF 32-4	681	428	430	530	45	46	30	24	160	178	220	140	218	238	110	135	100	51	9,6	124	280	362	417
CPE / CPEF 40-4	681	428	430	530	45	46	30	24	160	178	220	140	218	238	110	135	100	51	9,6	124	280	362	417
CPE / CPEF 50-2	681	428	430	530	45	46	30	24	160	178	220	140	218	238	110	135	100	51	9,6	124	280	362	417
CPE / CPEF 100-2	1068	651	-	555	60	52	40/45	-	160	178	705	315	-	408	135	256	92	62	-	390	280	362	417
Dimension	A3	A4	A5	A6	b	I	F	L1	L2	L3 (VTE)	L3 (VTEF)	L4	L5	L6 (VTE)	L6 (VTEF)	O	P (VTE)	P (VTEF)	S	t	T		
CPE / CPEF 16-8	143	465	298	178	150	142.5	209	263	292	296	213	312	342	346	125	197	205	229	b + 70	27	97		
CPE / CPEF 20-8	143	465	298	178	150	142.5	209	263	292	296	213	312	342	346	125	197	205	229	b + 70	27	97		
CPE / CPEF 25-5	143	465	298	178	150	142.5	209	263	292	296	213	312	342	346	125	197	205	229	b + 70	27	97		
CPE / CPEF 30-5	143	465	298	178	150	142.5	209	263	292	296	213	312	342	346	125	197	205	229	b + 70	27	97		
CPE / CPEF 32-4	143	615	298	178	150	142.5	209	263	292	296	253	272	302	306	125	197	205	229	b + 70	27	97		
CPE / CPEF 40-4	143	615	298	178	150	142.5	209	263	292	296	253	272	302	306	125	197	205	229	b + 70	27	97		
CPE / CPEF 50-2	143	615	298	178	150	142.5	209	263	292	296	253	272	302	306	125	197	205	229	b + 70	27	97		
CPE / CPEF 100-2	110	965	450	170	103	130	200	215	335	335	390	215	-	-	150	273	280	110	b + 98	40	97		



3 LINCOLN WAY, SHERBURN-IN-ELMET, LEEDS, WEST YORKSHIRE LS25 6PJ  
 Registered in England No. 3013233. V.A.T. Reg No. 599 2962 66  
[www.liftingsafety.co.uk](http://www.liftingsafety.co.uk) Email: [sales@liftingsafety.co.uk](mailto:sales@liftingsafety.co.uk)



**Yale**



### Electric and pneumatic chain hoists

Yale chain hoists convince through their compact, elegant design, low tare weight and their robust construction. A **precision machined, case hardened load chain sheave** perfectly matched to the load chain, oilbath lubricated gearbox with hardened gears and high quality encapsulated bearings ensure smooth, quiet operation.

The **adjustable slip clutch**, fitted as an overload safety device, is engineered for low maintenance and also serves as an **overrun protection** for the highest and lowest load hook positions.

The pendant control is fitted with an **EMERGENCY-STOP** switch as standard.

Forged suspension and load hooks, manufactured from non-ageing, high alloy tempering steel, yield under overload instead of breaking.

Apart from the stationary configurations (hook suspension) **manual push, geared and electric trolleys** are available. The trolleys are suitable for all commercial beam profiles e.g. INP, IPE and IPB. The compact connection between trolley and hoist produce an **optimal low headroom** dimension. The electric trolleys are fitted with a self-braking worm gearbox. The surface protected, high tensile load chains are in accordance with national and international standards and regulations (DIN EN 818).

All electric and air powered hoists are factory tested with overload. They are supplied with a test certificate showing the serial number and an operating instructions manual which contains an EC declaration of conformity.



Chain container  
optionally available!

#### Optional

- robust chain container
- stainless steel load chain (no reduction of working load limit)
- festooned cable system
- manual and powered trolleys with clevis or shackle to fit top hook suspended chain hoists
- Contactor control 48 V

## Electric chain hoist model CPS with top hook suspension

Capacities 125 - 500 kg

The new model CPS is the smallest and lightest within the family of Yale electric chain hoists. Reliability and compact design make it ideal for numerous applications in the construction industry, service companies and many industrial areas for moving small and medium loads.

#### Features

- **Extremely low headroom**
- The **10-pocket load sheave** ensures a smooth running of the chain and minimizes chain wear
- **2 year warranty** (excluding wear parts)
- **Thermal overload protection** as standard
- Electromagnetic spring pressure brake holds the load safely even in the event of power failure
- Robust aluminium housing, powder coated
- Classification 1 Am resp. 1 Bm. As required the model CPS (with appropriate changes to lifting capacity resp. duty cycle) can also be graded up to higher classifications. Motor protected to IP 54
- Standard operating current:  
Euro-voltage 400 V, 50 Hz, 3-phase.  
125 kg capacity also available for 230 V, 50 Hz, single phase
- The standard version comes with direct control
- Pendant control protected to IP 65 against ingress of dust and water
- The case hardened and zinc plated load chain has been specially adopted to the load sheave to avoid wear and increase operating safety. In accordance with national and international standards
- Forged top and bottom hooks made from age resistant alloy steel. They open up in case of excessive load without fracture. The top hook does not rotate in order to prevent the power cables from twisting.  
The bottom hook can rotate 360°.
- The overload protection (slip clutch) avoids overloading and extends the lifetime of the hoist

## Technical data

Model	Capacity kg	Chain strands	Standard lifting height m	Chain dimensions d x p in mm	Lifting speed m/min	Hoist motor kW	Weight kg	Operating current
<b>CPS 1-4</b>	125	1	3	4 x 12,2	4	0,10	11,5	230V/1Ph/50Hz
<b>CPS 1-10</b>	125	1	3	4 x 12,2	10	0,25	11,5	400V/3Ph/50Hz
<b>CPS 2-6</b>	250	1	3	4 x 12,2	6	0,28	11,5	400V/3Ph/50Hz
<b>CPS 5-3</b>	500	2	3	4 x 12,2	3	0,28	12,5	400V/3Ph/50Hz

\*Weight for standard 3 m lift. Other lifting heights available.

Capacity in kg	A mm	B mm	C mm	D mm	E mm	F mm	G mm	H mm	I mm	J* mm	X mm	Y mm	Z mm
125	276	98	159	75	76	160	227	103	52	1905	25	14	21
250	276	98	159	75	76	160	227	103	52	1905	25	14	21
500	303	146	159	60	91	160	227	103	52	1905	25	14	21

\*Dimensions for standard 3 m lift

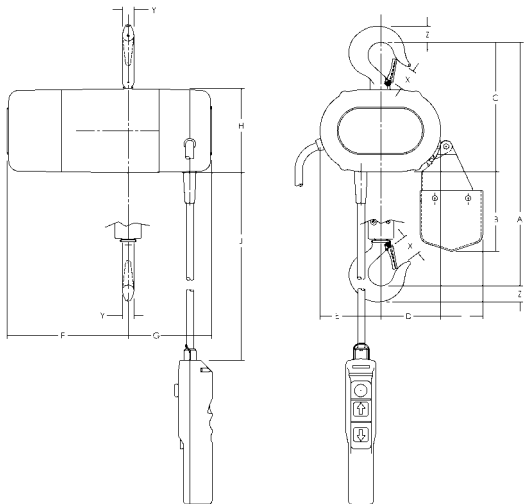



## Electric chain hoists

### CPM



#### Optional

- The models CPM 1-8, 2-8 (single chain fall), 5-4 (2 chain falls), 10-4 (single chain fall) and 20-2 (2 chain falls) are alternatively available in 230 V, 50 Hz, single phase (not available for CPM with electric trolley)
- Counters for operating hours and number of starts for advanced operation monitoring
- Other operating voltages on request
- Stainless steel load chain
- Chain container
- Festooned cable systems (see page 68)

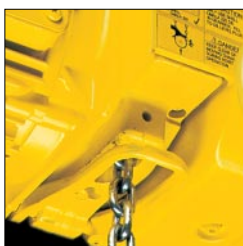

**Standard:**  
Limit switches

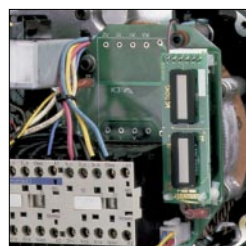

**Optional: Counter**  
for operating hours  
and starts

#### Electric chain hoist model CPM with suspension hook

Capacities 125 kg - 2.000 kg

#### Electric chain hoist model CPM with integral trolley

Capacities 125 kg - 2.000 kg

The model CPM is a robust, reliable and easy to service unit with a long service life.

The whole range is fitted with many standard features that were usually only available as extras.

The **integral limit switches** for the **highest and lowest hook positions** considerably extend the working life span of the slip clutch, motor and gearbox.

#### Features

- Classification 1 Am. As required the model CPM (with appropriate changes to lifting capacity resp. duty cycle) can also be graded up to the classification 3 m. All known domestic and European regulations of the classification according to FEM, ISO or BS are complied with resp. exceeded.
- Main contactor as standard, for increased safety.
- **Thermal overload protection** as standard for the whole range.
- Duty cycle 50 % ED for single speed.
- Electromagnetic, spring pressure brake holds the load safely even in the event of power failure.
- Motors according to VDE 0530 protected to IP55, against ingress of dust and water.
- Standard operating voltage: Euro-voltage 400 V, 50 Hz, 3-phase.
- Increased operating safety through 48 V control voltage (contactor control) and an encapsulated pendant control to IP 65.

## Technical data

Model	Capacity in kg/ chain falls	Chain dimensions d x p in mm	Lifting speed		Hoist motor kW	Motor rating ED %	Hook suspension kg	Net weight*	
			Main lift m/min	Fine lift m/min				Push** trolley kg	Electric*** trolley kg
<b>CPM 1-8</b>	125/1	5 x 15	8	–	0,4	50	21	32	41
<b>CPMF 1-8</b>	125/1	5 x 15	8	2	0,4/0,1	33/16	24	35	44
<b>CPM 1-12</b>	160/1	5 x 15	12	–	0,4	50	21	32	41
<b>CPMF 1-12</b>	160/1	5 x 15	12	3	0,4/0,1	33/16	24	35	44
<b>CPM 2-8</b>	250/1	5 x 15	8	–	0,4	50	21	32	41
<b>CPMF 2-8</b>	250/1	5 x 15	8	2	0,4/0,1	33/16	24	35	44
<b>CPM 3-6</b>	320/2	5 x 15	6	–	0,4	50	23	34	43
<b>CPMF 3-6</b>	320/2	5 x 15	6	1,5	0,4/0,1	33/16	26	37	48
<b>CPM 3-12</b>	320/1	6 x 18	12	–	0,8	50	33	44	53
<b>CPMF 3-12</b>	320/1	6 x 18	12	3	0,8/0,2	33/16	41	52	61
<b>CPM 5-4</b>	500/2	5 x 15	4	–	0,4	50	23	34	43
<b>CPMF 5-4</b>	500/2	5 x 15	4	1	0,4/0,1	33/16	26	37	46
<b>CPM 5-8</b>	500/1	6 x 18	8	–	0,8	50	33	44	53
<b>CPMF 5-8</b>	500/1	6 x 18	8	2	0,8/0,2	33/16	41	52	61
<b>CPM 6-6</b>	630/2	6 x 18	6	–	0,8	50	36	47	56
<b>CPMF 6-6</b>	630/2	6 x 18	6	1,5	0,8/0,2	33/16	44	55	64
<b>CPM 6-12</b>	630/1	8 x 24	12	–	1,6	50	51	63	78
<b>CPMF 6-12</b>	630/1	8 x 24	12	3	1,6/0,4	33/16	62	80	89
<b>CPM 10-4</b>	1000/2	6 x 18	4	–	0,8	50	36	47	56
<b>CPMF 10-4</b>	1000/2	6 x 18	4	1	0,8/0,2	33/16	44	55	64
<b>CPM 10-8</b>	1000/1	8 x 24	8	–	1,6	50	51	63	78
<b>CPMF 10-8</b>	1000/1	8 x 24	8	2	1,6/0,4	33/16	62	80	89
<b>CPM 12-6</b>	1250/2	8 x 24	6	–	1,6	50	58	76	85
<b>CPMF 12-6</b>	1250/2	8 x 24	6	1,5	1,6/0,4	33/16	69	87	96
<b>CPM 20-4</b>	2000/2	8 x 24	4	–	1,6	50	58	76	85
<b>CPMF 20-4</b>	2000/2	8 x 24	4	1	1,6/0,4	33/16	69	87	96

\*Weight for standard 3m lift. Other lifting heights available.

\*\*For trolleys type A and B: Additional weight for geared trolley (VTG): 2,5 kg

\*\*\*For electric trolley (VTE) with 2 speeds 2,0 kg.

## Technical data trolleys

Suitable for Model	Capacity kg	Size	Flange width mm	Curve radius min. m	Electric trolleys					
					Travel speed m/min at 50 Hz		Travel motor kW at 50 Hz			
from <b>CPM 1-8</b> to <b>CPMF 10-4</b>	1000	A	58 - 180	0,90	18	or	18/4,5	0,18	or	0,18/0,06
	1000	B	180 - 300	0,90	18	or	18/4,5	0,18	or	0,18/0,06
from <b>CPM 10-8</b> to <b>CPMF 20-4</b>	2000	A	58 - 180	1,15	18	or	18/4,5	0,18	or	0,18/0,06
	2000	B	180 - 300	1,15	18	or	18/4,5	0,18	or	0,18/0,06

## Dimensions CPM/CPMF in mm

Dimension	CPM/ CPMF 1-8	CPM/ CPMF 1-12	CPM/ CPMF 2-8	CPM/ CPMF 3-6	CPM/ CPMF 3-12	CPM/ CPMF 5-4	CPM/ CPMF 5-8	CPM/ CPMF 6-6	CPM/ CPMF 6-12	CPM/ CPMF 10-4	CPM/ CPMF 10-8	CPM/ CPMF 12-6	CPM/ CPMF 20-4
A	317	317	317	397	365	397	365	480	455	480	455	565	565
A <sub>1</sub>	167	167	167	167	205	167	205	205	252	205	252	252	252
A <sub>2</sub> (8 m)	409	409	409	409	-	409	-	-	589	-	589	589	589
A <sub>2</sub> (9 m)	-	-	-	-	497	-	497	497	-	497	-	-	-
B	22	22	22	22	22	22	22	29,5	29,5	29,5	29,5	40,5	40,5
B <sub>1</sub>	22	22	22	22	29,5	22	29,5	29,5	40,5	29,5	40,5	40,5	40,5
C	27	27	27	27	27	27	27	32	32	32	32	40	40
C <sub>1</sub>	27	27	27	27	32	27	32	32	40	32	40	40	40
D	14	14	14	14	14	14	14	14	19,5	19,5	19,5	26,5	26,5
D <sub>1</sub>	14	14	14	14	14	14	19,5	14	26,5	19,5	26,5	26,5	26,5
E	225	225	225	225	250	225	250	250	280	250	280	280	280
G	102	102	102	102	110	102	110	110	127	110	127	163	163
G <sub>1</sub> (8 m)	163	163	163	163	-	163	-	-	237	-	237	237	237
G <sub>1</sub> (9 m)	-	-	-	-	179	-	179	179	-	179	-	-	-
H	123	123	123	123	140	123	140	140	153	140	153	117	117
K (CPM)	285	285	285	285	285	285	285	285	345	285	345	345	345
K (CPMF)	310	310	310	310	365	310	365	365	390	365	390	390	390
M (8 m)	130	130	130	130	-	130	-	-	180	-	180	180	180
M (9 m)	-	-	-	-	150	-	150	150	-	150	-	-	-
N	240	240	240	240	294	240	294	294	295	294	295	295	295

**Model CPM**  
with suspension hook, single fall  
125 - 1.000 kg

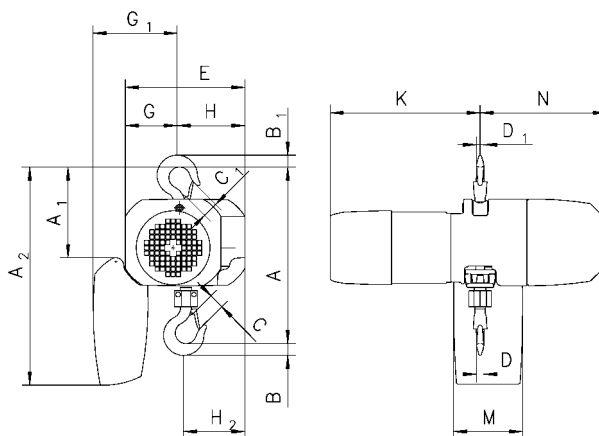

**Model CPM**  
with suspension hook, double fall  
320 - 2.000 kg

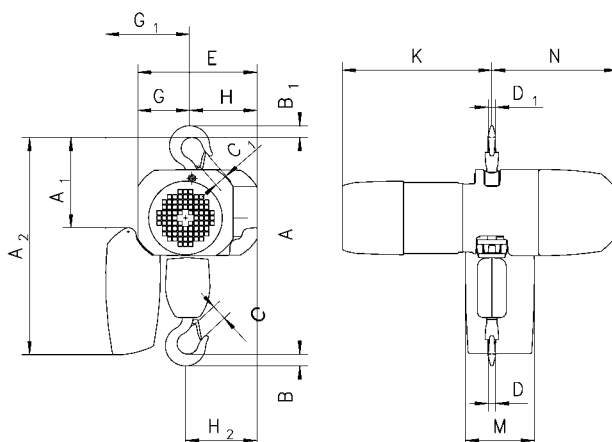

## Dimensions CPM/CPMF in mm

Dimension	CPM/ CPMF 1-8	CPM/ CPMF 1-12	CPM/ CPMF 2-8	CPM/ CPMF 3-6	CPM/ CPMF 3-12	CPM/ CPMF 5-4	CPM/ CPMF 5-8	CPM/ CPMF 6-6	CPM/ CPMF 6-12	CPM/ CPMF 10-4	CPM/ CPMF 10-8	CPM/ CPMF 12-6	CPM/ CPMF 20-4
A <sub>3</sub>	185	185	185	185	205	185	205	205	193	205	193	193	193
A <sub>4</sub> (8 m)	427	427	427	427	-	427	-	-	530	-	530	530	530
A <sub>4</sub> (9 m)	-	-	-	-	497	-	497	497	-	497	-	-	-
A <sub>5</sub>	335	335	335	415	365	415	365	480	396	480	396	506	506
H <sub>1</sub>	24	24	24	24	24	24	24	24	23,5	24	23,5	23,5	23,5
H <sub>2</sub>	111	111	111	132	122	132	122	144	152	144	152	116	116
H <sub>3</sub>	129	129	129	129	129	129	129	129	128	129	128	128	128
H <sub>4</sub> VTG	91,5	91,5	91,5	91,5	91,5	91,5	91,5	91,5	90,5	91,5	90,5	90,5	90,5
H <sub>4</sub> VTE	125	125	125	125	125	125	125	125	110	125	110	110	110
I	76,5	76,5	76,5	76,5	76,5	76,5	76,5	76,5	98	76,5	98	98	98
L VTP/VTG	310	310	310	310	310	310	310	310	360	310	360	360	360
L VTE (CPM)	410	410	410	410	410	410	410	410	435	410	435	435	435
L VTE (CPMF)	420	420	420	420	420	420	420	420	445	420	445	445	445
L <sub>1</sub>	130	130	130	130	130	130	130	130	150	130	150	150	150
L <sub>2</sub> (CPM)	255	255	255	255	255	255	255	255	255	255	255	255	255
L <sub>2</sub> (CPMF)	265	265	265	265	265	265	265	265	265	265	265	265	265
L <sub>3</sub>	155	155	155	155	155	155	155	155	180	155	180	180	180
L <sub>4</sub>	143	143	143	164	137	164	137	159	179	159	179	179	179
O	60	60	60	60	60	60	60	60	80	60	80	80	80
P	187	187	187	187	187	187	187	187	187	187	187	187	187
P <sub>1</sub>	295	295	295	295	295	295	295	295	295	295	295	295	295
S	b + 50	b + 50	b + 50	b + 50	b + 50	b + 50	b + 50	b + 50	b + 54	b + 50	b + 54	b + 54	b + 54
T	97	97	97	97	97	97	97	97	97	97	97	97	97
t	19	19	19	19	19	19	19	19	19	19	19	19	19

**Model CPM  
with integral manual  
push or geared trolley**

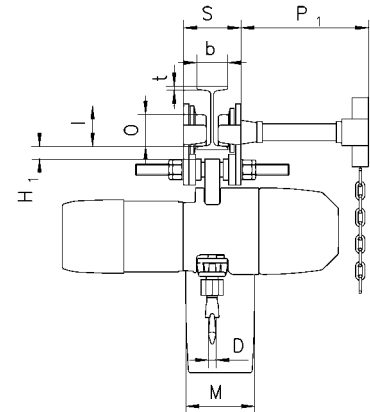
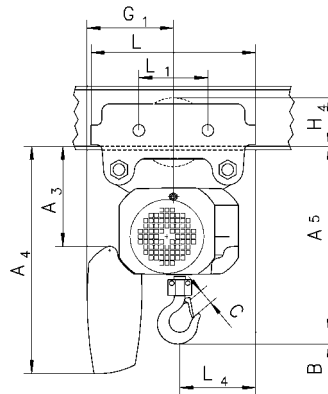

**Model CPM  
with integral electric trolley**

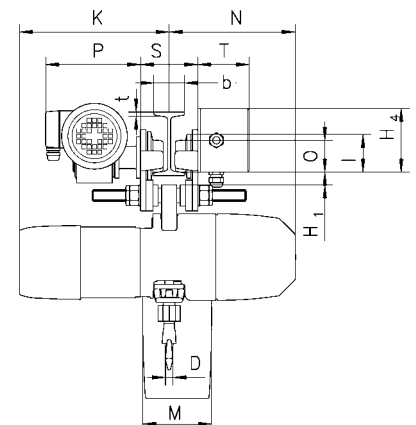
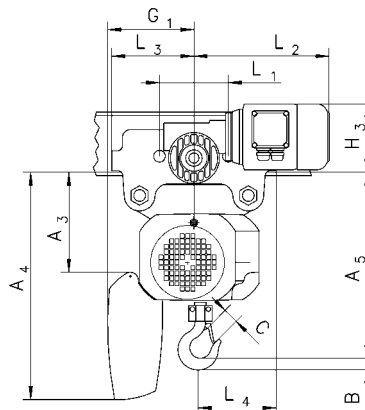

## Electric chain hoists

### CPE



#### Electric chain hoist model CPE with suspension hook

Capacities 1.600 - 10.000 kg

#### Electric chain hoist model CPE with integral trolley

Capacities 1.600 - 10.000 kg

The CPE series is a range of high quality products for professional applications. They are highly efficient and engineered for a long working life. The hoists are composed of three main component parts which makes service easy and inexpensive.

#### Features

- The standard, **oil bath lubricated planetary gearbox** is particularly smooth running and enables a **low overall height** (see dimension A in the dimension table on page 62).
- The standard version comes with direct control. Contactor control (42V) is optionally available.
- The **5-pocket load chain sheave**, manufactured from wear resistant case hardening steel, is matched perfectly to the load chain to guarantee smooth and precise chain motion.
- Case hardened and zinc plated link chain.
- The heavy duty squirrel cage motor has an adjustable spring pressure brake that holds the load secure even in the event of a power failure.
- The **motor** is designed **for high duty cycles**.
- **Motor** fitted **with a bimetallic thermal protection** (useable in connection with optional low voltage control).
- 400 or 230 V, 3-phase, 50 Hz - Euro-voltage, resp. 460 or 230 V, 3-phase 60 Hz.  
Versions with two speed trolley  
VTEF 400 V, 50 Hz resp. 460 V, 60 Hz.
- Motor protected to IP 54, Insulation class F

The units are certified by the employer's liability insurance association and fulfil the requirements of the machinery directive 98/37 EWG.

### Optional

- 42 V low voltage control
- Other operating voltages on request
- Suspension hook rotated 90°
- Motor with stainless steel brake
- Stainless steel load chain
- Flexible chain container
- Limit switches for highest and lowest hook positions

## Twin hoist model CPE 100-2

Capacity 10.000 kg

The model CPE 100-2 consists of two CPE 50-2 units. They are connected by a framework. Hook suspension, geared or electric trolleys are available. Integral limit switches for highest and lowest hook positions are standard.



**Festooned cable systems**  
see page 68-69



#### 5-pocket load chain sheave

machined for smooth, precise chain motion



#### Universal connection

to suspension hook, trolley or steel structures



#### Double fall bottom block

for capacities up to 5t

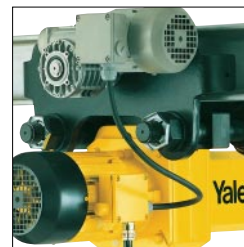

#### Hoist connected directly to trolley

with electric drive. Manual pull and geared trolleys also available



#### Optional: Flexible chain container

made from wear resistant textile fabric

## Technical data

### CPE



Model	Capacity in kg/ chain falls	Chain dimensions d x p in mm	Lifting speed		Hoist motor kW	Motor rating ED %	Suspension hook kg	Net weight*		Electric** trolley kg
			Main lift m/min	Fine lift m/min				Push trolley kg	Geared trolley kg	
<b>CPE 16-8</b>	1600/1	11 x 31	8	–	2,3	40	88	150	154	164
<b>CPEF 16-8</b>	1600/1	11 x 31	8	2	2,3/0,58	40/20	93	155	159	169
<b>CPE 20-8</b>	2000/1	11 x 31	8	–	2,8	25	88	150	154	164
<b>CPEF 20-8</b>	2000/1	11 x 31	8	2	2,8/0,7	25/15	93	155	159	169
<b>CPE 25-5</b>	2500/1	11 x 31	5	–	2,3	40	88	150	154	164
<b>CPEF 25-5</b>	2500/1	11 x 31	5	1,25	2,3/0,58	40/20	93	155	159	169
<b>CPE 30-5</b>	3000/1	11 x 31	5	–	2,8	25	88	150	154	164
<b>CPEF 30-5</b>	3000/1	11 x 31	5	1,25	2,8/0,7	25/15	93	155	159	169
<b>CPE 32-4</b>	3200/2	11 x 31	4	–	2,3	40	107	169	173	182
<b>CPEF 32-4</b>	3200/2	11 x 31	4	1	2,3/0,58	40/20	112	174	178	187
<b>CPE 40-4</b>	4000/2	11 x 31	4	–	2,8	25	107	169	173	182
<b>CPEF 40-4</b>	4000/2	11 x 31	4	1	2,8/0,7	25/15	112	174	178	187
<b>CPE 50-2</b>	5000/2	11 x 31	2,5	–	2,3	40	107	169	173	182
<b>CPEF 50-2</b>	5000/2	11 x 31	2,5	0,6	2,3/0,58	40/20	112	174	178	187
<b>CPE 100-2</b>	10000/4	11 x 31	2,5	–	2 x 2,3	40	282	–	385	406
<b>CPEF 100-2</b>	10000/4	11 x 31	2,5	0,6	2 x 2,3/0,58	40/20	287	–	390	411

\*Weight for standard 3m lift. Other lifting heights on request.

\*\*Additional weight for 2 speed version 2,0 kg

Chain container for CPE 16-8 to CPEF 50-2: 13 resp. 21m chain, for CPE/CPEF 100-2: 2 x 21m chain

### Technical data trolleys

Capacity kg	Size	Flange width mm	Curve radius min. m	Electric trolley	
				Travel speed m/min at 50 Hz	Motor kW at 50 Hz
1600 - 5000	A	98 - 180	1,8	11 or 11/2,8	0,37 or 0,3/0,09
1600 - 5000	B	180 - 300	1,8	11 or 11/2,8	0,37 or 0,3/0,09
10000	B	125 - 310	1,8	5 or 5/1,25	0,55 or 0,55/0,12

### Questionnaire for choosing a suitable electric chain hoist

Company \_\_\_\_\_

Contact \_\_\_\_\_

Street/Code/City \_\_\_\_\_

Telephone/Telefax \_\_\_\_\_

#### Details about intended use

---

---

---

---

#### Required capacity

---

#### Lifting height

---

#### Ambient conditions

- Normal
- Humidity
- Dust
- Dirt
- Particular temperatures °C
- Increased rel. humidity %

Other

---

#### How long is the hoist in operation

- \_\_\_\_\_ Load cycles per hour
- \_\_\_\_\_ Hours per day
- \_\_\_\_\_ Days per week
- \_\_\_\_\_ Distance covered per lifting cycle

#### Unusual operating conditions that could be important for the choice and function of the electric chain hoist

#### Type of load

- Permanent       Changing
- Shocks           Vibration
- Static

#### Trolley drive

- Motor               Manual

#### Operating voltage

- 400 V               230 V
- 3-phase a.c.       1-phase a.c.

#### Power frequency

- 50 Hz               60 Hz

#### Protection

- IP 54               Other

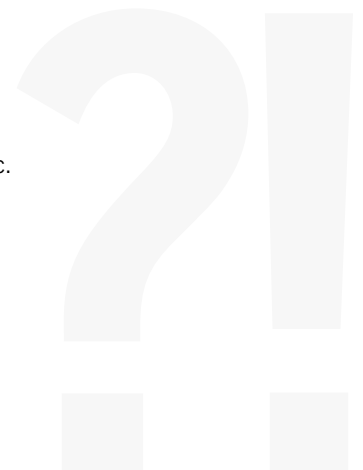



## Dimensions CPE/CPEF in mm

Dimension	CPE/CPEF 16-8	CPE/CPEF 20-8	CPE/CPEF 25-5	CPE/CPEF 30-5	CPE/CPEF 32-4	CPE/CPEF 40-4	CPE/CPEF 50-2	CPE/CPEF 100-2
A	516	516	516	516	681	681	681	1068
A <sub>1</sub>	286	286	286	286	428	428	428	651
A <sub>2</sub> (13 m)	430	430	430	430	430	430	430	-
A <sub>2</sub> (21 m)	530	530	530	530	530	530	530	555
B	35	35	35	35	45	45	45	60
C	37	37	37	37	46	46	46	52
D	24	24	24	24	30	30	30	40/45
E	24	24	24	24	24	24	24	-
F <sub>1</sub>	160	160	160	160	160	160	160	160
F <sub>2</sub>	178	178	178	178	178	178	178	178
G	220	220	220	220	220	220	220	705
G <sub>1</sub>	180	180	180	180	140	140	140	315
G <sub>2</sub> (13 m)	257	257	257	257	218	218	218	-
G <sub>2</sub> (21 m)	277	277	277	277	238	238	238	408
H <sub>1</sub>	110	110	110	110	110	110	110	135
H <sub>2</sub>	135	135	135	135	135	135	135	256
K <sub>1</sub>	100	100	100	100	100	100	100	92
K <sub>2</sub>	51	51	51	51	51	51	51	62
M	50,0	50,0	50,0	50,0	9,6	9,6	9,6	-
N	84	84	84	84	124	124	124	390
Q <sub>1</sub>	280	280	280	280	280	280	280	280
Q <sub>2</sub> (CPE)	362	362	362	362	362	362	362	362
Q <sub>2</sub> (CPEF)	417	417	417	417	417	417	417	417

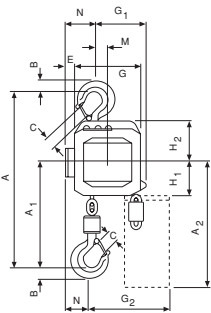

**Model CPE with suspension hook, single fall**  
1.600 - 3.000 kg

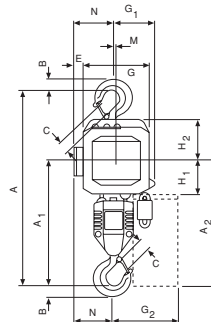
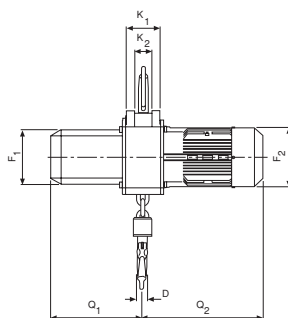

**Model CPE with suspension hook, double fall**  
3.200 - 5.000 kg

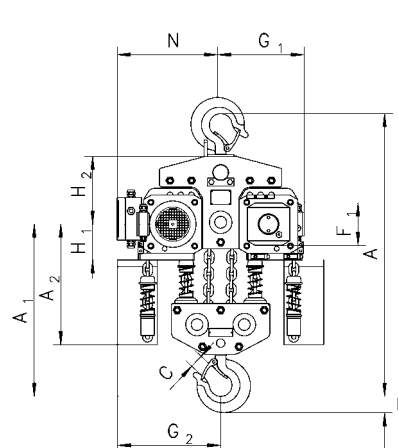
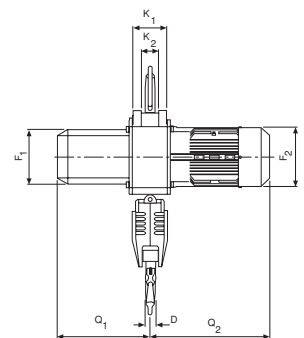

**Model CPE 100-2 with suspension hook**  
10.000 kg

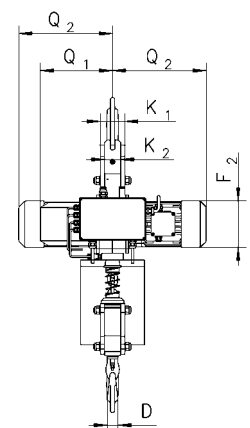

## Dimensions CPE/CPEF in mm

Dimension	CPE/CPEF 16-8	CPE/CPEF 20-8	CPE/CPEF 25-5	CPE/CPEF 30-5	CPE/CPEF 32-4	CPE/CPEF 40-4	CPE/CPEF 50-2	CPE/CPEF 100-2
A <sub>3</sub>	143	143	143	143	143	143	143	110
A <sub>4</sub>	465	465	465	465	615	615	615	965
A <sub>5</sub>	298	298	298	298	298	298	298	450
A <sub>6</sub>	178	178	178	178	178	178	178	170
b	A = 98 - 180 / B = 180 - 300							
F	150	150	150	150	150	150	150	103
I	142,5	142,5	142,5	142,5	142,5	142,5	142,5	130
L <sub>1</sub>	209	209	209	209	209	209	209	200
L <sub>2</sub>	262,5	262,5	262,5	262,5	262,5	262,5	262,5	215
L <sub>3</sub> (VTE)	292	292	292	292	292	292	292	335
L <sub>3</sub> (VTEF)	296	296	296	296	296	296	296	335
L <sub>4</sub>	213	213	213	213	253	253	253	390
L <sub>5</sub>	312	312	312	312	272	272	272	215
L <sub>6</sub> (VTE)	342	342	342	342	302	342	342	-
L <sub>6</sub> (VTEF)	346	346	346	346	306	306	306	-
O	125	125	125	125	125	125	125	150
P (VTE)	197	197	197	197	197	197	197	273
P (VTEF)	205	205	205	205	205	205	205	280
P <sub>1</sub>	229	229	229	229	229	229	229	110
S	b + 70	b + 70	b + 70	b + 70	b + 70	b + 70	b + 70	b + 98
t	27	27	27	27	27	27	27	40
T	97	97	97	97	97	97	97	97

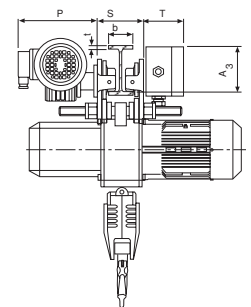
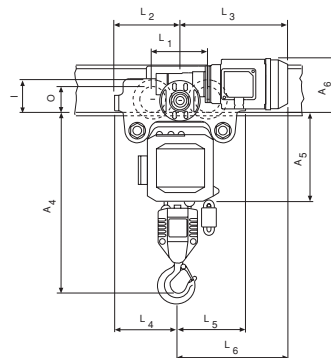
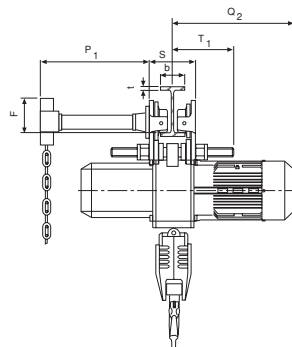
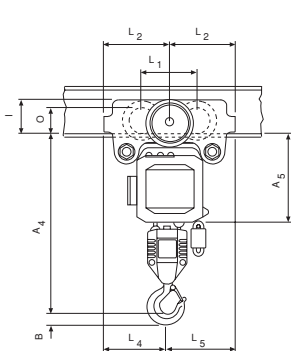

**Model CPE**  
with integral push or geared trolley

**Model CPE**  
with integral electric trolley

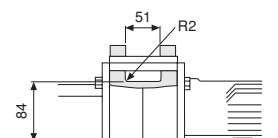
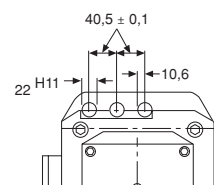
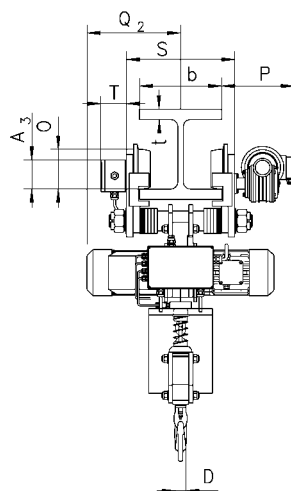
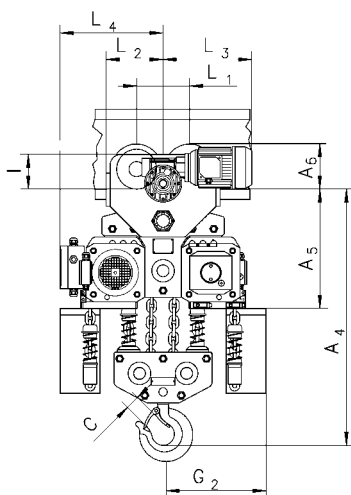

**Model CPE 100-2, with integral electric trolley**  
10.000 kg

### General information about electric chain hoists

Apart from the usual criterion such as lifting capacity, lifting speed and dimensions also consider following:

#### 1. Choosing a motor according to FEM 9.682

In addition to the torque the decisive criterion for rating an electric motor is the heat it generates. Here we differentiate between two operational modes.

##### 1.1 Intermittent duty

In this case the motor is designed for a series of equal cycles consisting of duty periods with constant load and rest periods. The heat generation depends on the relative duty cycle, that is, the relationship between operating period under load, total operating time and the number of starts/hour.

$$\text{Duty rating} = \frac{\text{Operating period}}{\text{Operating period} + \text{rest periods}} \times 100\%$$

The number of cycles that can be made under full load is calculated as follows:

$$S \approx 0,3 \times \frac{ED \times V}{H}$$

- S = Cycles per hour
- ED = Duty rating in %
- V = Lifting speed in m/min.
- H = Average lifting height in m

A cycle consists of a motion of lifting, lowering and the rest periods. One must ensure that the lifting height does not exceed the value permitted by the percentage duty cycle referred to a cycle period of 10 minutes

$$H \leq \frac{ED \times V}{20}$$

and that simultaneously the permissible number of starts is not exceeded. It is generally accepted that a cycle consists of 6 starts.

##### 1.2 Short time duty

Where special duty conditions exist (e.g. long hook path) the operating period must be of such length that the admissible temperature limit of the motor is not exceeded. For such cases intermittent duty must be replaced by short time duty. That is, the motor may be operated for up to 10 starts over a certain period (usually 15 min.). Thereafter the motor must cool down to room temperature.

##### 1.3 Calculation example intermittant duty

Electric hoist	:	CPM 5-8
Lifting speed	:	8 m/min.
Lifting height	:	2,8 m
Duty rating ED	:	50 %
c/h	:	180

##### Number of cycles per hour

$$S = 0,3 \times \frac{50 \times 8}{2,8} = 42,8$$

##### Max. lifting height

$$H = 2,8 \leq \frac{50 \times 8}{20} = 20 \text{ m}$$

##### Number of starts

$$N = \frac{25 \text{ cycles}}{\text{hour}} \times \frac{6 \text{ starts}}{\text{cycle}} = 150$$

## 2. Classification of hoisting equipment according to FEM 9.511

To choose an optimal hoist the lifting capacity and also the classification group must be known. The classification group indicates the theoretical operating time of the mechanical components under full load:

Classification group	1Bm	1Am	2m
Operating time in h	400	800	1600

If the hoist is operated as classified an actual operating time of around 10 years can be expected. After this period a general overhaul is necessary.

To define the classification group following values must be determined:

### 2.1 Average operating time per day

The average operating time can be estimated or calculated as follows:

$$\text{Operating time/day} = \frac{2 \times \text{average hook path} \times \text{cycles /hour} \times \text{operating time/day}}{60 \times \text{lifting speed}}$$

**Electric hoists provided with counters for operating hours and number of starts simplify the classification (see CPM page 54)**

### 2.2 Load spectrum

The load spectrum indicates to what extent a hoist or part thereof is subject to maximal stress or whether it is subject to smaller loads only. It can be calculated or estimated according to the diagrams on the right:

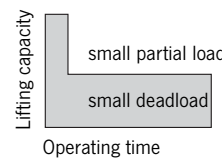

**1 light**  
Hoists or parts thereof usually subject to very small loads and in exceptional cases only to maximum loads.

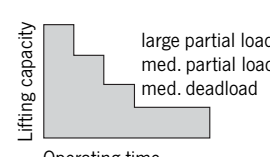

**2 medium**  
Hoists or parts thereof usually subject to small loads but rather often to maximum loads.

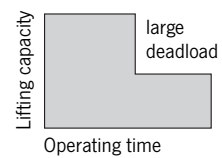

**3 heavy**  
Hoists or parts thereof usually subject to medium loads but frequently to maximum loads.

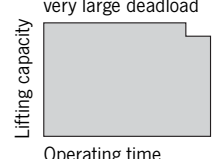

**4 very heavy**  
Hoists or parts thereof usually subject to maximum or almost maximum loads.

### 2.3 Classification

The classification group is defined by operating hours and load spectrum:

Load spectrum	Aver. op. hours per working day		
1 light	up to 2	2-4	4-8
2 medium	up to 1	1-2	2-4
3 heavy	up to 0,5	0,5-1	1-2
4 very heavy	up to 0,25	0,25-0,5	0,5-1
Classification group acc. to FEM/DIN 15020	1Bm	1Am	2m

### Degrees of protection according to EN 60529

Depending on the operating and environmental conditions the damaging effect of water, foreign particles and dust and the contact with live or moving parts inside a motor is to be prevented by choosing a suitable protection.

The marking used to indicate the degree of protection consists of the letters IP followed by two characteristic numerals.

The marking applies to the unit as it is supplied and the defined or usual location of the unit.

The protection can change if the unit is located or fitted differently.

IP	1 <sup>st</sup> digit for protection against ingress of solid foreign particles 0 to 6	2 <sup>nd</sup> digit for protection against ingress of liquid 0 to 8
----	---	---

#### Motor cooled internally

Protection	1 <sup>st</sup> digit contact protection	ingress of solid foreign particles	2 <sup>nd</sup> digit ingress of liquid
IP 00	no protection	no protection	no protection
IP 02	no protection	no protection	drops of water when tilted up to 15° from vertical
IP 11	large surface contact	foreign bodies over 50 mm Ø	vertical water drops
IP 12			drops of water when tilted up to 15° from vertical
IP 13			spray water when tilted up to 60° from vertical
IP 21	contact with fingers	foreign bodies over 12 mm Ø	vertical water drops
IP 22			drops of water when tilted up to 15° from vertical
IP 23			spray water when tilted up to 60° from vertical

#### Motor surface cooled

IP 44	contact with tools or similar	against solid foreign bodies over 1 mm Ø	spray water from all directions
IP 54			spray water from all directions
IP 55	complete protection against contact	damaging dust deposits	water jet from all directions
IP 56			momentarily flooding
IP 65	complete protection against contact	against ingress of dust	water jet from all directions

Terminal boxes are usually supplied with protection IP 54 resp. IP 55.

## Protection against contact and solid foreign particles

### First digit 0

#### No protection

No protection of persons against contact with live or moving parts inside the enclosure. No protection of equipment against ingress of solid foreign particles.

### First digit 1

#### Protection against large solid foreign particles

Protection against accidental or inadvertent contact with live or moving parts inside the enclosure by a large surface of the human body, e.g. hand, but not protected against deliberate access to such parts.

### First digit 2

#### Protection against medium size solid foreign particles

Protection against contact with live or moving parts inside the enclosure by fingers. Protection against ingress of medium size solid foreign particles of diameter greater than 12 mm.

### First digit 3

#### Protection against small solid foreign particles

Protection against contact with live or moving parts inside the enclosure by tools, wires or such objects of thickness greater than 2.5 mm. Protection against ingress of small solid foreign particles of diameter greater than 2,5 mm.

### First digit 4

#### Protection against granular structured foreign particles

Protection against contact with live or moving parts inside the enclosure by tools, wires or such objects of thickness greater than 1 mm. Protection against ingress of granular structured solid foreign particles of diameter greater than 1 mm.

### First digit 5

#### Protection against dust deposits

Complete protection against contact with live or moving parts inside the enclosure. Protection against harmful deposits of dust. The ingress of dust is not totally prevented, but dust cannot enter in an amount sufficient to interfere with the satisfactory operation of the equipment enclosed.

### First digit 6

#### Complete protection

Complete protection against contact with live or moving parts inside the enclosure. Protected against the ingress of dust.

<sup>2)</sup> In certain cases water should not ingress. As required this is defined on the follow-on page of the unit in question.

## Protection against liquids

### Second digit 0

#### No protection

No particular protection.

### Second digit 1

#### Protection against vertical water drops

Drops of condensed water falling on the enclosure shall have no harmful effects

### Second digit 2

#### Protection against diagonal falling water drops

Protection against drops of liquid. Drops of falling liquid shall have no harmful effect when the enclosure is tilted at any angle up to 15° from the vertical.

### Second digit 3

#### Protection against spray water

Protection against drops of liquid. Water falling in rain at an angle equal to or smaller than 60° with respect to the vertical shall have no harmful effect.

### Second digit 4

#### Protection against splashing

Liquid splashed from any direction shall have no harmful effect.

### Second digit 5

#### Protection against water jets

Water projected by a nozzle from any direction under stated conditions shall have no harmful effect.

### Second digit 6

#### Protection against flooding

Protection against conditions on ships decks (deck watertight equipment). Water from heavy seas shall not enter the enclosure under prescribed conditions <sup>2)</sup>.

### Second digit 7

#### Protection against immersion in water

It shall not be possible for water to enter the enclosure under stated conditions of pressure and time <sup>2)</sup>.

### Second digit 8

#### Protection against indefinite immersion

Protection against indefinite immersion in water. Under specific pressure it shall not be possible for water to enter the enclosure <sup>2)</sup>.