

*Endless winch
up to 500 kg!*



STANDARD
This image shows the
Yale Mtrac winch with
standard equipment.

PATENTED*
BI-DIRECTIONAL ACTUATOR
FOR BI-DIRECTIONAL
LIFTING

*German Patent DE 10 2012 100 099

Yale Mtrac®

Endless winch

Capacity 66 - 500 kg

(two-fall design up to 1000 kg, optional)

The Yale Mtrac® endless winch combines state-of-the-art industrial design with technical innovation to solve a specific customer need – the need for a safe and simple handling solution for mobile applications.

We did just that. Because the rope of the endless winch is not collected during operation, there is no limit to the lifting height and traction length when using this product. And, with a full offering of wire ropes and accessories, this winch can be used in virtually any application requiring a hoist., e.g. on construction sites, in maintenance and assembly, in wind mills and power supply, water and utility sector, overhead line maintenance, etc.

Features

- Control pendant (IP 65-type of enclosure) is connected via a control cable.
- Standard power cable has a length of 1.0 m and is fitted with a CE connector plug (or a Schuko-plug).
- 42 V low-voltage control
- Ergonomic, fitted carrying handle features a comfortable plastic grip.
- Mounting feet fixed on the housing for easy set up.
- Standard operating voltages of 400 V, 3-ph, 50 Hz or 230 V, 1-ph, 50 Hz.
- Galvanized, high-density steel rope is 10 m long (dia. 6.5 mm) and features a safety hook on one end as well as a rounded, plastic-coated tip at the loose end.
- Two spring buffers with adjusting rings can be attached to the wire rope to set the limit switches for both upward and downward movement.
- Drive sheave is made of especially hardened steel designed to ensure long service life.
- The patented (German Patent DE 10 2012 100 099) bi-directional actuator ensures the rope is safely guided and securely held in place.
- Slip clutch is located outside of the load path for added safety.
- Limit switches ensure safe cut-out for the upper and lower hook positions.
- Electromagnetic brake holds the load safely, even in the event of a power failure.
- Winch is classified up to 1 Bm/M3 acc. to FEM/ISO.
- Winch is protected up to IP 55.

FEATURES

PATENTED* BI-DIRECTIONAL ACTUATOR

The Yale *Mtrac* endless winch features a unique bi-directional actuator that allows the winch to move the rated load on both ends of the rope. A hook can be fitted on the unloaded rope end (as an option) thus eliminating no-load motions. How does it work? Once the load has reached the top position, the unloaded rope end with the other hook is automatically in the bottom position and a new load can be picked up immediately. The lifting frequency is doubled as the two falls can be evenly loaded alternately with the rated load.

*German Patent DE 10 2012 100 099

READY TO USE

Each winch leaves our factory as a complete plug and play unit.

The control cable with control pendant is connected, as is the power supply cable with the plug. The standard design also features a wire rope complete with fitted safety hook. The carrying handle is included as standard and load-bearing feet are provided on the lower part of the housing.

STATE-OF-THE-ART INDUSTRIAL DESIGN

A compact and state-of-the-art design was at the focus of the Yale *Mtrac*. The housing is made of low-pressure, die-cast aluminum and the high-strength, glass-fiber reinforced plastic covers ensure low weight and outstanding rigidity. A carrying frame, available as an option, allows for easy, two-person transport and provides additional protection against damage when moving the unit or operating it in rough conditions.

VERSATILE APPLICATION

Mtrac winches can be used vertically, at an angle or horizontally for versatility depending on your application. Optionally, the load capacity can be doubled with two-fall reeving. Bolting points on the housing allow the customer to attach the winch in a way that best suits their application.

PROVEN TECHNOLOGY

Mtrac winches include reliable and proven Yale technology. The oil-bath lubricated and case-hardened gearbox has a helical gearing for smooth operation and a long service life. IP 55-rated motor enclosure ensures reliable operation of the winch for both indoor and outdoor applications.

BEST-IN-CLASS SAFETY

Standard winch models feature 42 V low-voltage control with built-in limit switches designed to stop the hoist when the hook has reached the upper or lower position. The operator can define the limit switch positions by simply relocating the spring buffers on the rope. The winch is also protected against overload by means of a slip clutch that is designed to guarantee a permanent connection between the load and the brake.

SIMPLE MAINTENANCE

Yale *Mtrac* winches are easy to service. Units are designed with a modular structure with all critical parts easily accessible. Re-adjusting the slip clutch and inspecting the brake is quick and easy as well. In addition, the handle, or carrying frame, can be quickly and easily assembled and removed.

ERGONOMIC DESIGN

Standard units have a comfortable plastic grip that allows for convenient one-person transport. The optional carrying frame features a grip on each handle, making two-person transport easy. And, because of the rounded housing, operator injury is minimized.



STANDARD
This image shows the Yale *Mtrac* winch with standard equipment.



Capacity up to 1000 kg

TWO-FALL DESIGN
with optional components such as suspension hook and bottom block.

Yale Mtrac winches with two carrying frames (optional) are extremely well protected and can be safely operated in any position.



The accessories for the two-part reeved option double the load capacity.

OPTIONAL FEATURES

BI-DIRECTIONAL LIFTING

To realize the full potential of this winch, operators can utilize the bi-directional actuator. Simply fit an additional hook at the loose rope end to take advantage of this unique feature. Once the hook is in place, the unit can be used in bi-directional lifting mode (two-hook mode). The actuator is mounted in the interior of the winch and ensures the rope smoothly runs in the drive sheave. It also extends the pressure surface of the rope on the drive sheave for safe friction contact. The two load falls are designed to alternately carry the rated load.

CARRYING FRAME

The carrying frame on the Yale Mtrac can be installed either at the top or at the bottom on the unit. It is ergonomically designed with plastic grips that ensure hand-friendly handling and carrying of the winch by two people. The carrying frame cannot be used as a load-bearing component; it is exclusively intended to protect the housing, e.g. while working, during storage or while transporting or carrying the winch. Two carrying frames can also be used (one at the top and one at the bottom).

CONNECTION TO TROLLEYS

If low headroom is required, the Yale Mtrac winch can be easily converted from the standard hook connection to a trolley mount using a Yale trolley. Manual and power-driven trolleys available on request.

OPTIONAL

- The transport and carrying frames are designed to protect the housing.
They must not be used as load-bearing components!
- Two-part reeving configuration doubles the load capacity.
- Additional hook kit for bi-directional lifting.
- Special voltages on request.
- Steel wire ropes of various lengths.
- Manual and electric trolleys.
- Frequency converter for variable speed control or smooth starting.
- Operating hours counter to determine the remaining service life and number of switching operations.
- Radio remote control with extended operation range.
- Varying lengths for power and control cables.
- Stainless steel wire ropes (with shorter service life than standard).

PATENTED*

BI-DIRECTIONAL ACTUATOR FOR BI-DIRECTIONAL LIFTING

*German Patent DE 102012 100099



Optional:
Radio remote control



BI-DIRECTIONAL LIFTING

This image shows the Yale Mtrac's optional second hook that allows for bi-directional lifting operation.

The hooks of the two rope falls can be alternately loaded with 100% rated load.

BI-DIRECTIONAL LIFTING

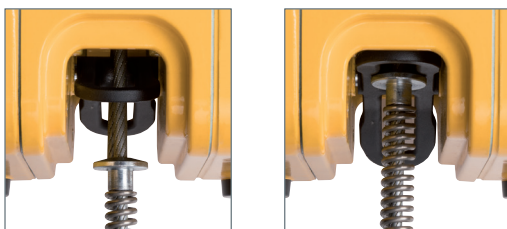
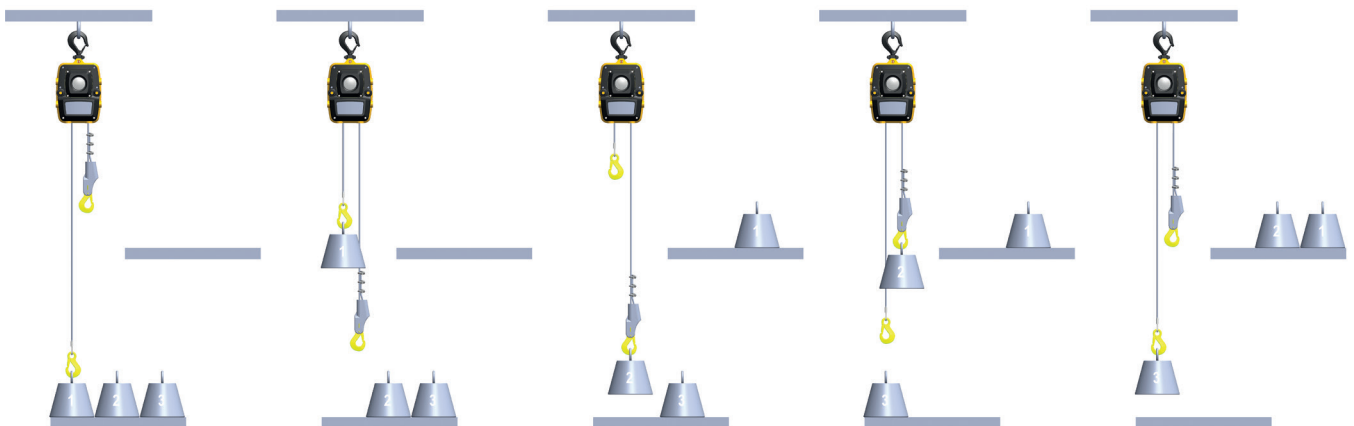

LIMIT SWITCHES AND LIMIT SWITCH ACTUATOR

The spring buffers attached to the rope trip the limit switch actuator when they contact the paddle, which in turn actuates the micro-switches that stop the hoisting motion (via the low voltage control).

Technical data YaleMtrac

Model	Art.-No.	Single fall Standard		Double fall Optional		Motor kW	Operating voltage
		Capacity kg	Lifting speed m/min	Capacity kg	Lifting speed m/min		
YMT 1-15	192025166	100	15	200	7.5	0.37	230V/1 Ph/50 Hz
YMT 3-5	192025170	300	5	600	2.5	0.37	230V/1 Ph/50 Hz
YMTF 0,6-30	192025175	66	30/7.5	130	15/3.7	0.37/0.09	400V/3 Ph/50 Hz
YMT 1-30	192025171	100	30	200	15	0.55	400V/3 Ph/50 Hz
YMTF 2-10	192025176	200	10/2.5	400	5/1.3	0.37/0.09	400V/3 Ph/50 Hz
YMT 3-10	192025174	300	10	600	5	0.55	400V/3 Ph/50 Hz
YMT 5-5	192053140	500	5	1000	2.5	0.55	400V/3 Ph/50 Hz

Weight from 24 to 26 kg (without rope) depending on options.

Rope \varnothing 6.5 mm

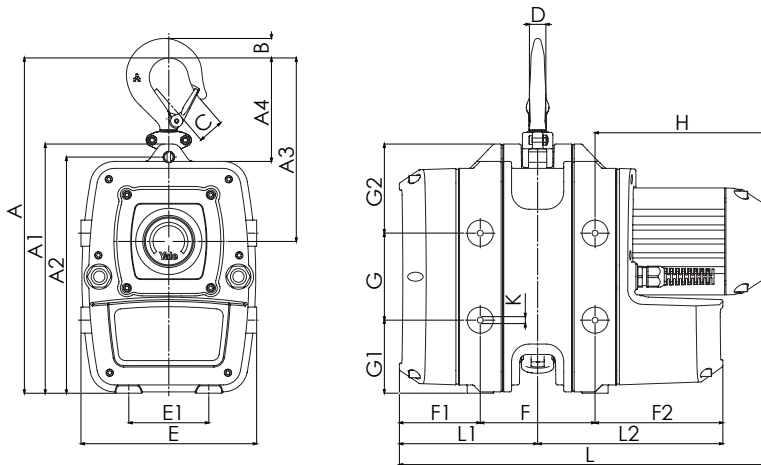

Dimensions	
A, mm	385
A1, mm	287
A2, mm	272
A3, mm	221
A4, mm	119
B, mm	22
C, mm	29
D, mm	19
E, mm	202
E1, mm	92
F, mm	132
F1, mm	93
F2, mm	147
G, mm	100
G1, mm	84
G2, mm	103
H, mm	201
K, mm	M8
L, mm	426
L1, mm	159
L2, mm	213



INFO

Yale hoists and trolleys are not designed for passenger elevation applications and must not be used for this purpose.