

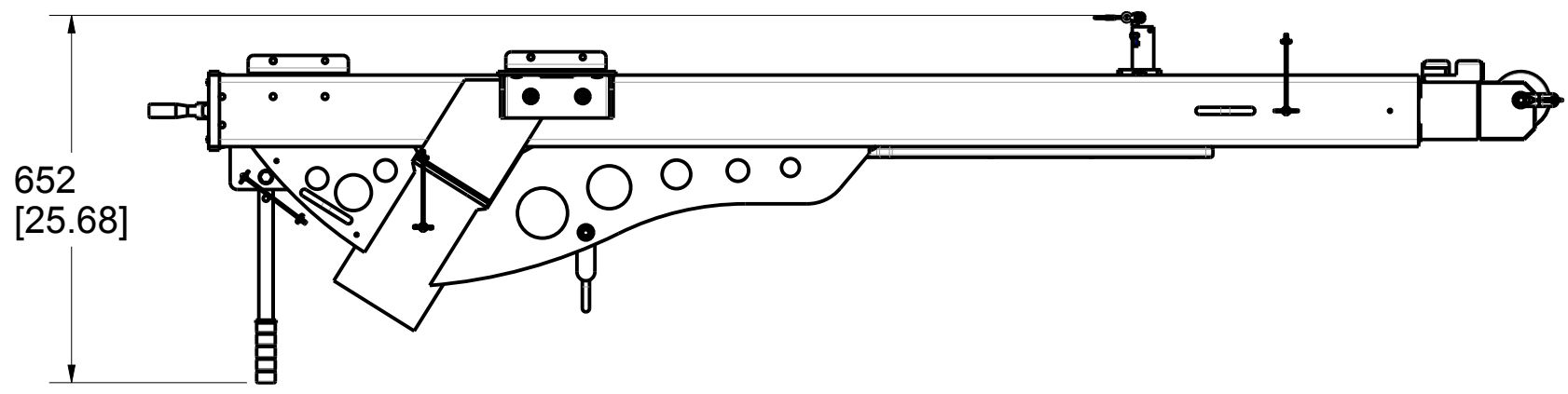

Product number: IN-2197

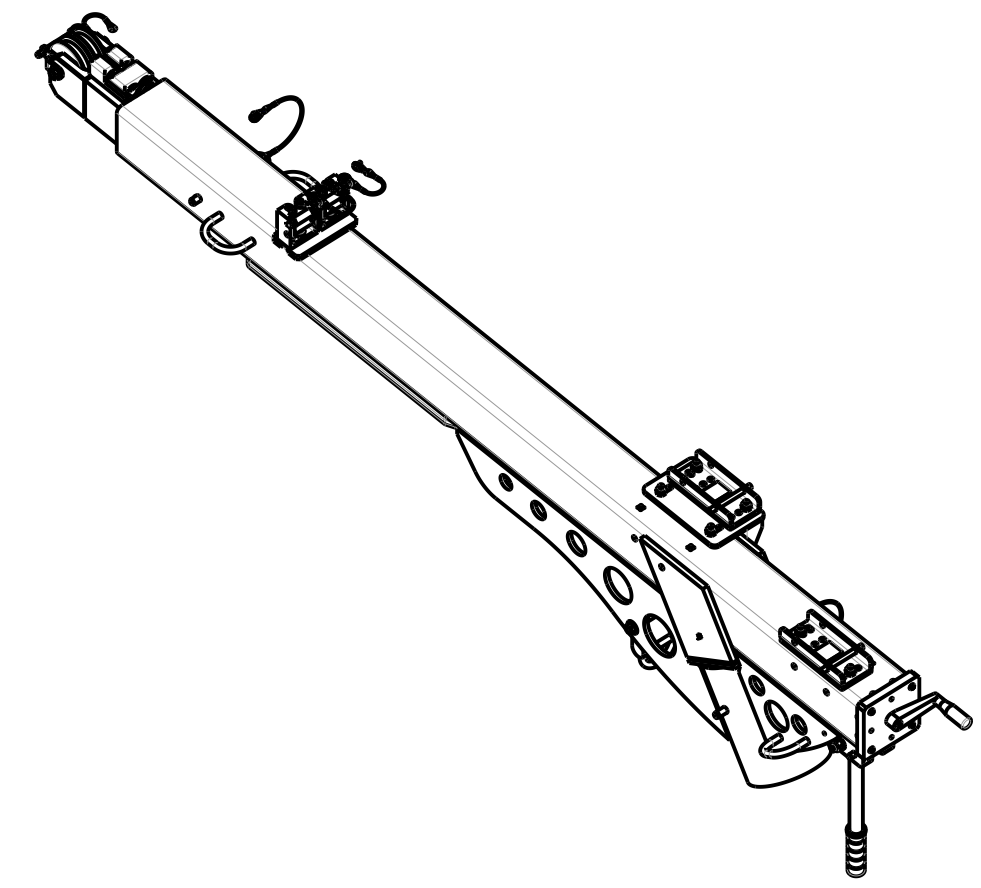
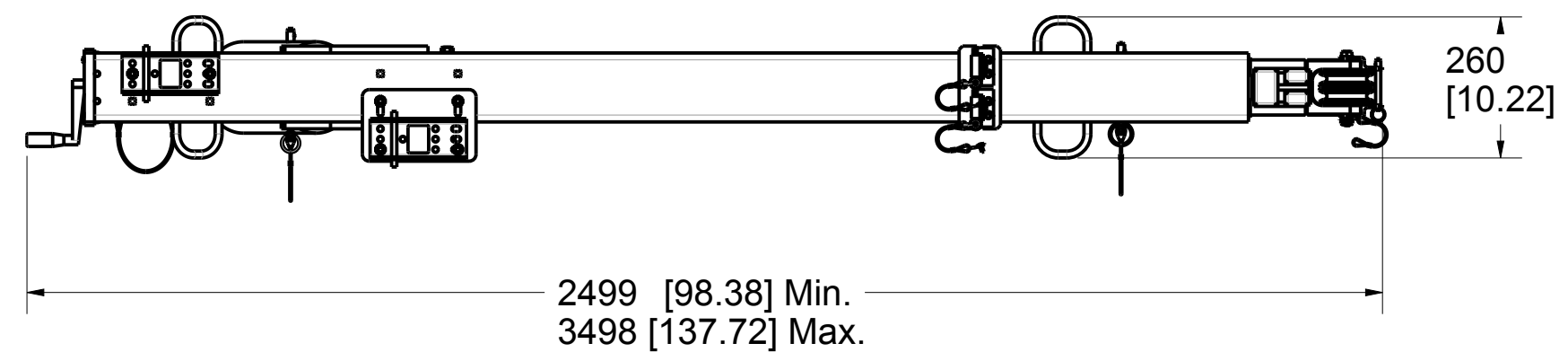
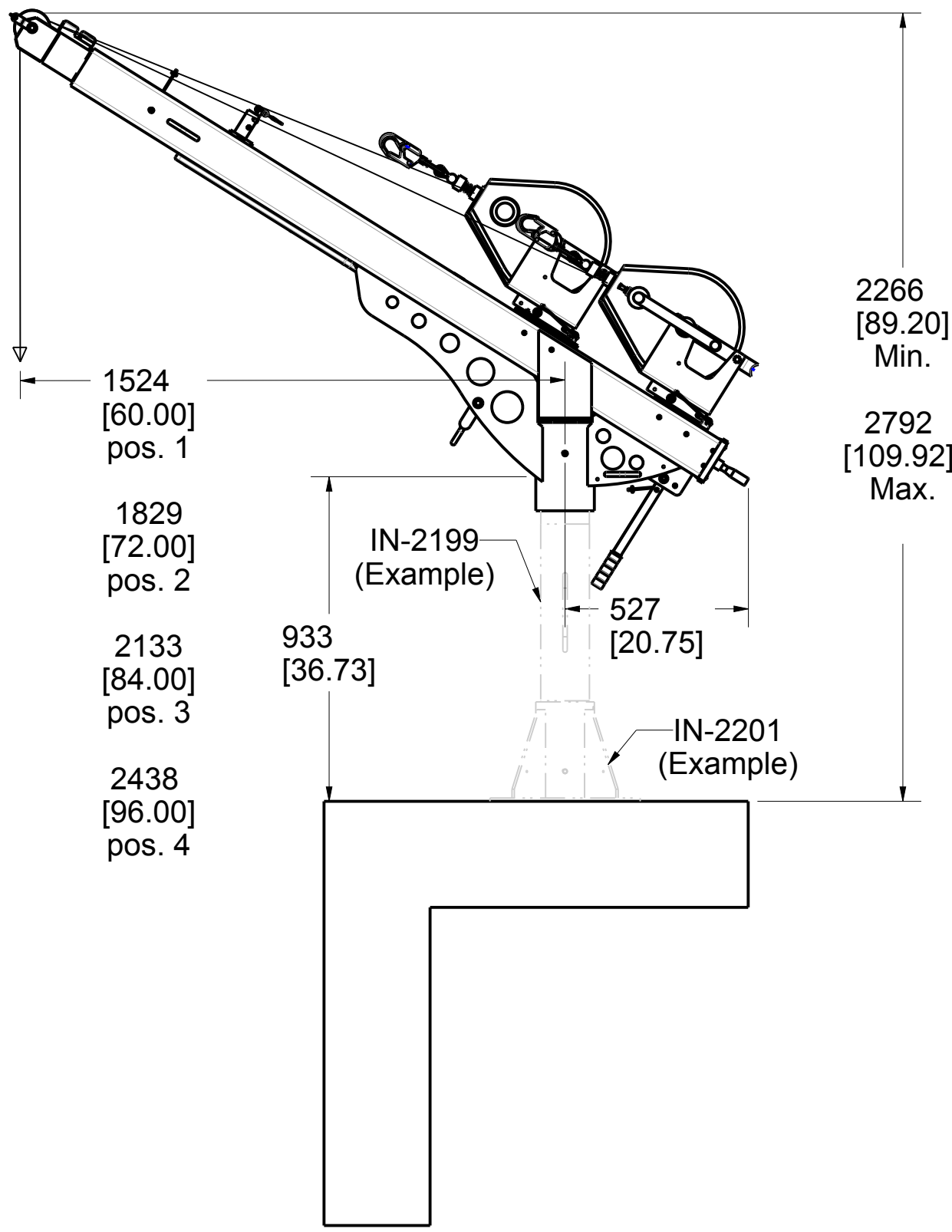

PAT.NO.:				
PRODUITS DE SERVICE PUBLICS INNOVA INC. INNOVA PUBLIC UTILITY PRODUCTS INC.				
© 9105-0732 QUEBEC INC. and under exclusive license to INNOVA PUBLIC UTILITY PRODUCTS INC., (hereafter « INNOVA »). All rights reserved. Protected under the Copyright Act of Canada and international treaties and agreements regarding copyrights. Violators are subject to prosecution and other legal recourses for infringement. Any reproduction, adaptation or other use or disclosure whatsoever, in totality or in part, and in any form or by any means whatsoever, strictly forbidden and requires the prior written approval of INNOVA. All data is the exclusive property of 9105-0732 QUEBEC INC. and under exclusive license to INNOVA and cannot be used nor disclosed in any way either without the prior written approval of INNOVA.				
WEIGHT:	TITLE:			
140 Lb	1524 - 2438 mm (60"- 96")			
64 Kg	Extendable davit arm			
COLOR:	Material:	SHEET(S):	PROJET:	Rev.
Yellow security	Aluminum 6061-T6	1 / 4	IN-2197	06

Product number: **IN-2197**



PAT.NO.:				
PRODUITS DE SERVICE PUBLICS INNOVA INC. INNOVA PUBLIC UTILITY PRODUCTS INC.				
© 9105-0732 QUEBEC INC. and under exclusive license to INNOVA PUBLIC UTILITY PRODUCTS INC., (hereafter « INNOVA »). All rights reserved. Protected under the Copyright Act of Canada and international treaties and agreements regarding copyrights. Violators are subject to prosecution and other legal recourses for infringement. Any reproduction, adaptation or other use or disclosure whatsoever, in totality or in part, and in any form or by any means whatsoever, strictly forbidden and requires the prior written approval of INNOVA. All data is the exclusive property of 9105-0732 QUEBEC INC. and under exclusive license to INNOVA and cannot be used nor disclosed in any way either without the prior written approval of INNOVA.				
WEIGHT:	TITLE:			
140 Lb	1524 - 2438 mm (60"- 96")			
64 Kg	Extendable davit arm			
COLOR:	Material:	SHEET(S):	PROJET:	Rev.
Yellow security	Aluminum 6061-T6	2 / 4	IN-2197	06

SPECIFICATIONS

This equipment is considered as part of a personal fall arrest system (PFAS).
 It is only to be used in conjunction with a personal fall arrest system that limits the maximum arrest force (MAF) to 6.0 kN.

Working load limit (WLL) : 164 kg (360 lb)
 Minimum breaking strength for anchorage 1 & 2 : 16,0 kN (3 600 lbf)
 Minimum breaking strength for anchorage 3 : 22,2 kN (5 000 lbf)

STANDARDS

Name	Classification	Year	Users
AS/NZS 5532	Freefall Arrest	2013	1
ANSI Z359.18	D	2017	1
CSA Z259.15	AD	2017	1
OSHA 1910.140			1
OSHA 1926.502			1
EN 795	A	2012	1
TS 16415		2013	3

MATERIAL AND CONSTRUCTION

Structure : Aluminum 6061-T6
 Anchorage 1 & 2 : 44W / 50W Steel (Zinc plated)
 Anchorage 3 : Stainless Steel 304
 Hardware : Stainless Steel , Steel (Zinc plated)
 Sliders : UHMW (Polyethylene)
 Pulleys : Acetal
 Surface finish : Yellow high durability powder coatings
 Welding certification : Steel / Stainless Steel : CSA W59.18 / CSA W47.1 and AWS D1.6
 Aluminum : CSA W59.2 / CSA W47.2

RESTRICTIONS

This equipment is to be used only with products approved by Innova Public Utility Products Inc.
 This equipment must always be operated on a level surface.
 Ensure that all hardwares and connecting pins are properly installed before use.
 In the occurrence of a fall or that the safety of the equipment is in doubt, the equipment must be immediately removed from service and inspected by qualified personnel before reuse.

Product number: **IN-2197**

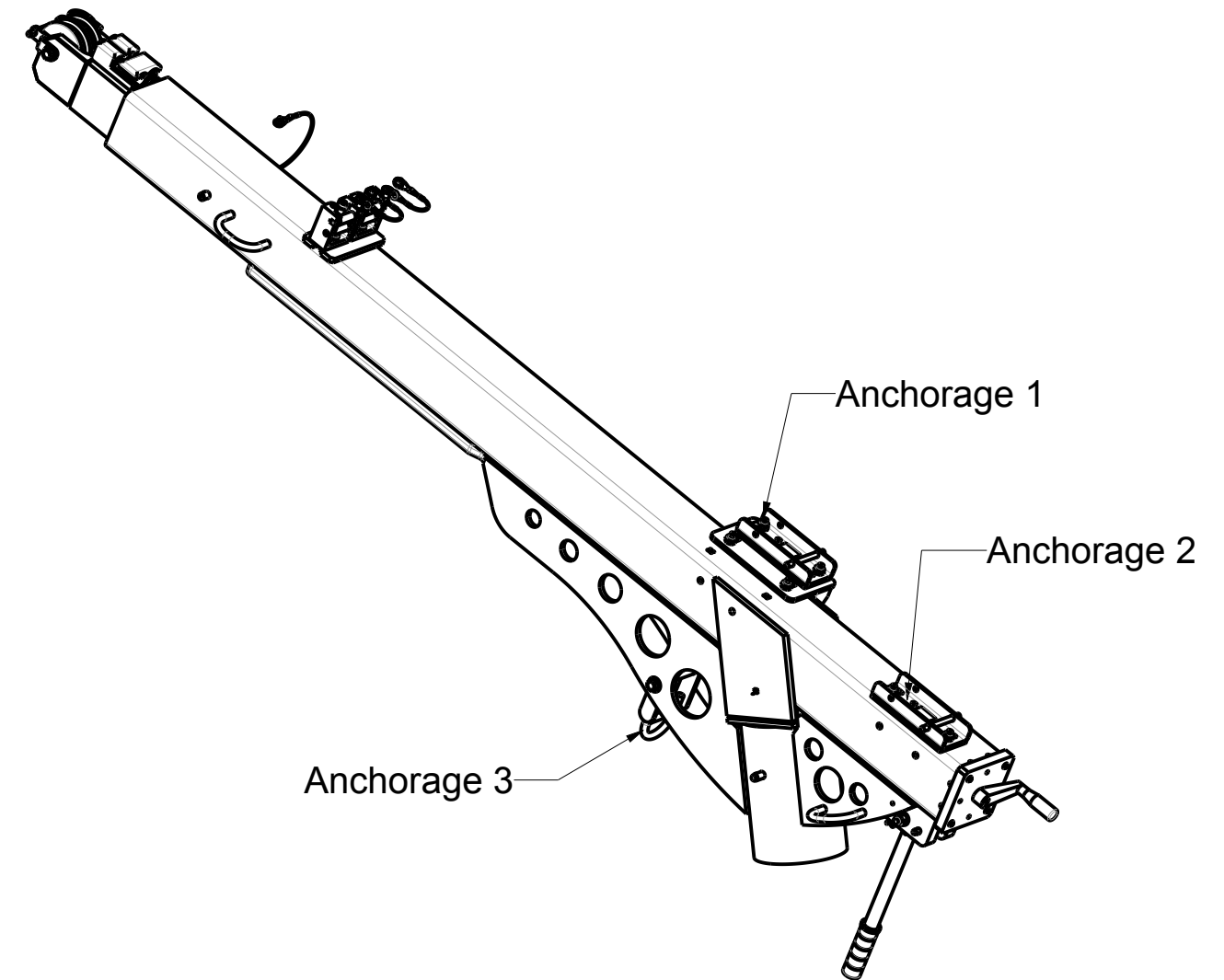

PAT.NO.:				
PRODUITS DE SERVICE PUBLICS INNOVA INC. INNOVA PUBLIC UTILITY PRODUCTS INC.				
© 9105-0732 QUEBEC INC. and under exclusive license to INNOVA PUBLIC UTILITY PRODUCTS INC., (hereafter « INNOVA »). All rights reserved. Protected under the Copyright Act of Canada and international treaties and agreements regarding copyrights. Violators are subject to prosecution and other legal recourses for infringement. Any reproduction, adaptation or other use or disclosure whatsoever, in totality or in part, and in any form or by any means whatsoever, strictly forbidden and requires the prior written approval of INNOVA. All data is the exclusive property of 9105-0732 QUEBEC INC. and under exclusive license to INNOVA and cannot be used nor disclosed in any way either without the prior written approval of INNOVA.				
WEIGHT:	TITLE:			
140 Lb	1524 - 2438 mm (60"- 96")			
64 Kg	Extendable davit arm			
COLOR:	Material:	SHEET(S):	PROJET:	Rev.
Yellow security	Aluminum 6061-T6	3 / 4	IN-2197	06

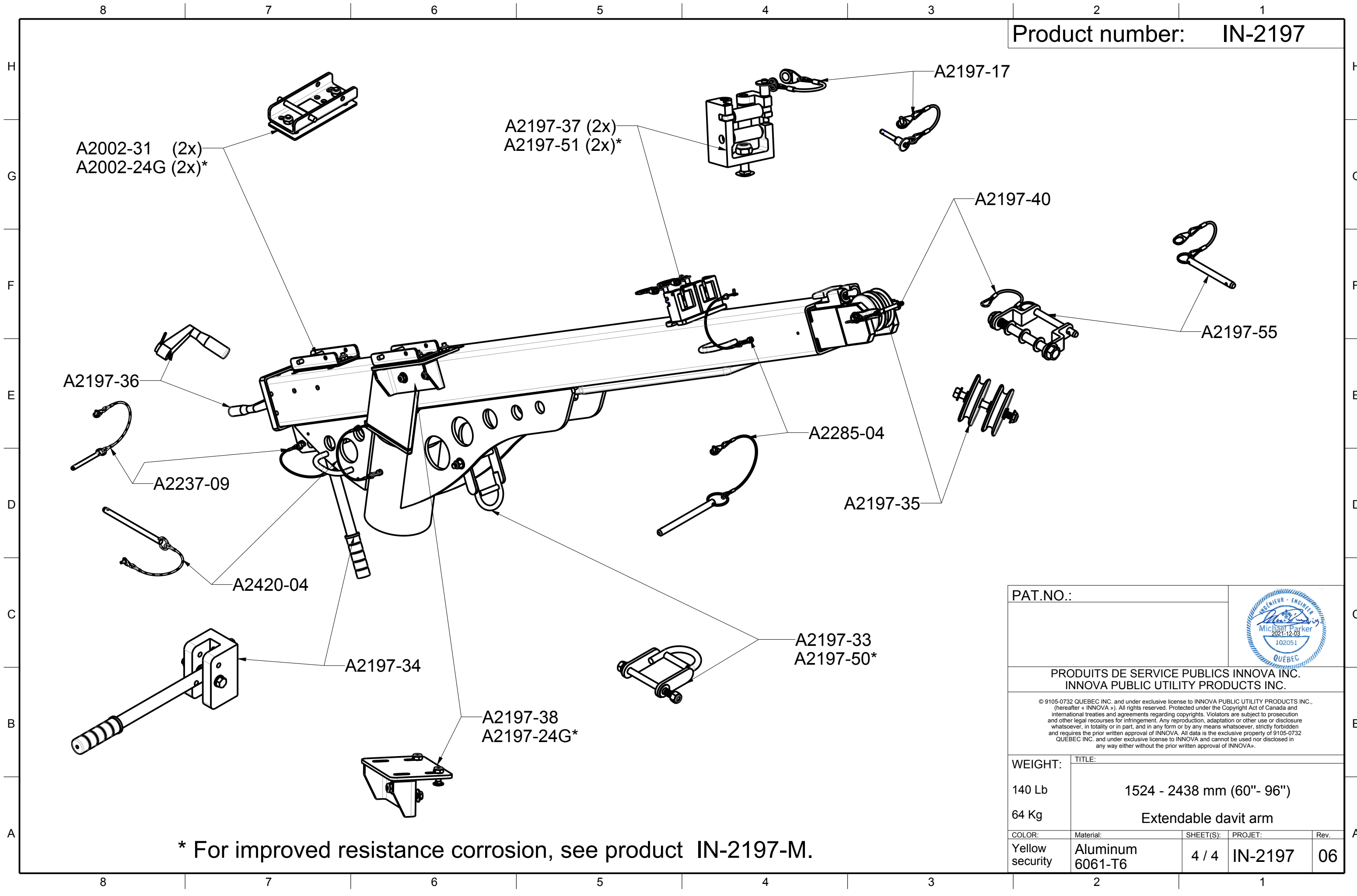

* For improved resistance corrosion, see product IN-2197-M.

PAT.NO.:				
PRODUITS DE SERVICE PUBLICS INNOVA INC. INNOVA PUBLIC UTILITY PRODUCTS INC.				
© 9105-0732 QUEBEC INC. and under exclusive license to INNOVA PUBLIC UTILITY PRODUCTS INC., (hereafter « INNOVA »). All rights reserved. Protected under the Copyright Act of Canada and international treaties and agreements regarding copyrights. Violators are subject to prosecution and other legal recourses for infringement. Any reproduction, adaptation or other use or disclosure whatsoever, in totality or in part, and in any form or by any means whatsoever, strictly forbidden and requires the prior written approval of INNOVA. All data is the exclusive property of 9105-0732 QUEBEC INC. and under exclusive license to INNOVA and cannot be used nor disclosed in any way either without the prior written approval of INNOVA*.				
WEIGHT:	TITLE:			
140 Lb	1524 - 2438 mm (60"- 96")			
64 Kg	Extendable davit arm			
COLOR:	Material:	SHEET(S):	PROJET:	Rev.
Yellow security	Aluminum 6061-T6	4 / 4	IN-2197	06