

Anode Jacks

Duff-Norton was the originator of the Anode Jack, which was developed in partnership with the Aluminum Industry. Our jacks were used in the first commercial aluminum-making plant in the United States and continue to be used in aluminum plants throughout the world.

The alumina smelting process involves high temperatures and loads. The Duff-Norton anode jack is a heavy-duty version of our standard actuator, and has been modified for each smelting facility's specific application.

The Anode Jack's worm gears are made of wear resistant bronze and are up to 40% larger than our standard versions. Along with the larger worm gears are larger bearings and heavy-duty seals. Sealing is very important because the alumina dust is very abrasive. Anode jacks use only heat-treated alloy steel worms. Additionally, high temperature grease is used. These jacks have a large overload capacity to handle the side loading stresses caused by the thermal expansions and contractions of the frames. They are also built to take the compressive overloads caused by occasional highjacking of the frames and frozen pots.

Features

- Oversized worm and gear set
- Heavy duty load bearings
- Heavy duty seals
- High temperature resistant grease
- Translating or Rotating models available

In addition to these jacks, Duff-Norton can also supply anode-jacking arrangements, which include the motor, reducer, shafting and couplings for your complete system requirements.

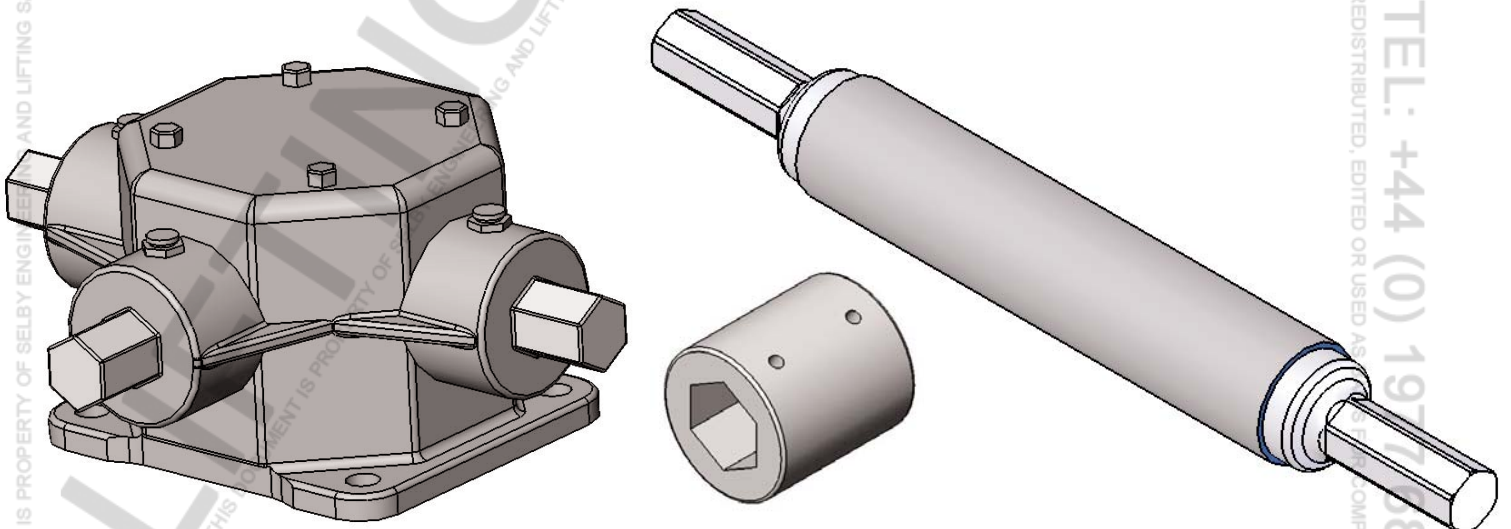

Anode Jacks

Inverted Rotating Style Anode Jack

Inverted Translating Style Anode Jack

Elasticone Cover Optional

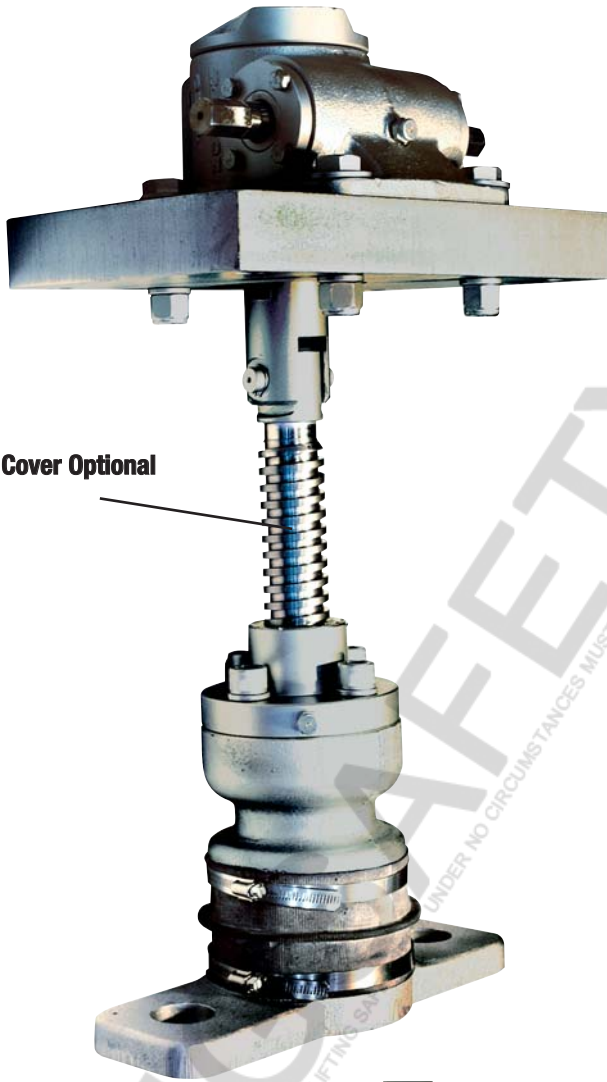

Oversized Clevis, Knurled Ring, & Cover Pipe



Heavy Duty Worm Seals & Grease Fittings



Trunnion Base & Upper Yoke



Cover Pipe with Heavy Duty Cap



Special Corrosion Resistant Paint



Hex Worm Shafts



Connecting Link, Clevis Pinned Screw, & Lifting Nut