



ISO 9001 REGISTERED

&

CE CERTIFIED



**MAN RATED  
CONFINED SPACE  
ENTRY/RETRIEVAL SYSTEMS  
UCL POLE HOIST**

**OPERATOR'S MANUAL**

SELBY ENGINEERING AND LIFTING SAFETY LTD. TEL: +44 (0) 1977 684 600

LIFTINGSAFETY.CO.UK

**LIMITED WARRANTY**

This Limited Warranty is given exclusively to:

\_\_\_\_\_  
Name

\_\_\_\_\_  
Address

Telephone No.

by Unique Concepts Ltd. ("Unique Concepts") in respect of the following product(s) manufactured by it (the "Products"):

\_\_\_\_\_  
\_\_\_\_\_  
\_\_\_\_\_

Subject to the conditions and restrictions contained in this Limited Warranty, Unique Concepts warrants to the Customer that the Products are free from defects in materials and workmanship under normal use and service for a period of twelve (12) months from the date the Products are purchased by the Customer, in new and unused condition, from Unique Concepts or its agent (the "Warranty Period"). Unique Concepts' entire liability and the Customer's exclusive remedy regarding any such defects is limited to the repair or replacement of the defective Products (as Unique Concepts, in its sole discretion, deems appropriate) which are returned to Unique Concepts in accordance with the procedures set forth below.

Terms and Conditions

1. This Limited Warranty will be void unless:
  - (a) this Limited Warranty is fully completed by or on behalf of the Customer and returned to Unique Concepts within fourteen (14) days following the date the Customer purchases the Products, by registered mail addressed to: Unique Concepts Ltd., 1500 King Edward Street, Winnipeg, Manitoba, R3H 0R5 (the "Manufacturer's Address");
  - (b) written notice of any defect is delivered to the Manufacturer's Address by registered mail within five (5) days after any defect in the Products becomes apparent; and
  - (c) any defective Products in respect of which the Customer wishes to make a warranty claim are delivered to Unique Concepts, with all postage or freight charges prepaid, within the Warranty Period and no later than fourteen (14) days after any defect in the Products becomes apparent.
  
2. This Limited Warranty shall not apply to any Products which have been used with unapproved assemblies or sub-assemblies, or which have been customized or modified, altered, damaged or misused.
  
3. Following the repair or replacement of any defective Products in respect of which a warranty claim is validly made by the Customer, or, alternatively, following the date Unique Concepts determines either that the warranty given hereby has been voided or that the returned Products do not exhibit any defects in materials or workmanship, Unique Concepts will return the Products to the Customer. All such shipments will be made to the Customer's address listed above, and will be at the Customer's sole expense.

4. The Customer will incur all risk of loss, theft or damage to the Products during shipment to Unique Concepts and during their subsequent return to the Customer. Without limiting the foregoing, the common carrier chosen by Unique Concepts to return the Products to the Customer will be deemed to be an agent of the Customer.

5. If, on its inspection of any Products returned to it by the Customer, Unique Concepts determines that such Products require maintenance or repairs which are outside the scope of its warranty obligations. Unique Concepts may contact the Customer with a view to obtaining authorization (which may be written or oral) to complete such maintenance or repairs at rates then customarily charged by Unique Concepts to its customers. The Customer hereby releases and indemnifies Unique Concepts, together with its directors, officers, agents, employees, successors and assigns, and anyone else who has been involved in the inspection of the Products returned by the Customer, from all claims, losses, expenses and damages (including damages for loss of business profits, business interruption, loss of business information, loss of health or for any other loss whatsoever) arising directly or indirectly, as a result of the failure by Unique Concepts to perform or adequately perform any maintenance or repairs which are outside the scope of its warranty obligations hereunder, whether or not resulting from any negligent or improper inspection of such Products, or from the failure of the Customer to authorize the performance of such maintenance or repairs.

6. THE WARRANTY SET OUT HEREIN IS THE ONLY WARRANTY OF ANY KIND, EITHER EXPRESS OF IMPLIED, STATUTORY OR OTHERWISE (INCLUDING BUT NOT LIMITED TO THE IMPLIED WARRANTIES OR MERCHANTABILITY AND FITNESS FOR A PARTICULAR PURPOSE) THAT IS MADE BY UNIQUE CONCEPTS. WITHOUT LIMITING THE GENERALITY OF THE FOREGOING, UNIQUE CONCEPTS DOES NOT WARRANT THAT THE PRODUCTS WILL MEET ALL REQUIREMENTS OF ALL APPLICABLE LAWS, REGULATIONS OR OTHER ENACTMENTS APPLICABLE IN EACH JURISDICTION IN WHICH THEY MAY BE USED OR STORED, OR THE REQUIREMENTS OF THE CUSTOMER.

7. NO ORAL OR WRITTEN INFORMATION OR ADVICE GIVEN BY UNIQUE CONCEPTS, ITS DEALERS, DIRECTORS, OFFICERS, DISTRIBUTORS, AGENTS OR EMPLOYEES SHALL CREATE A WARRANTY OR IN ANY WAY INCREASE THE SCOPE OF THIS LIMITED WARRANTY, AND THE CUSTOMER MAY NOT RELY ON ANY SUCH INFORMATION OR ADVICE.

8. THE CUSTOMER AGREES THAT, TO THE MAXIMUM EXTENT PERMITTED UNDER APPLICABLE LAW, NEITHER UNIQUE CONCEPTS NOR ITS DEALERS, DIRECTORS, OFFICERS, DISTRIBUTORS, AGENTS OR EMPLOYEES, OR ANYONE ELSE WHO HAS BEEN INVOLVED IN THE CREATION, PRODUCTION OR DELIVERY OF THE PRODUCTS, WILL BE LIABLE FOR ANY DIRECT, INDIRECT, CONSEQUENTIAL OR INCIDENTAL DAMAGES (INCLUDING DAMAGES FOR LOSS OF BUSINESS PROFITS, BUSINESS INTERRUPTION, LOSS OF BUSINESS INFORMATION, LOSS OF HEALTH OR ANY OTHER LOSS WHATSOEVER) ARISING OUT OF THE USE OR INABILITY TO USE SUCH PRODUCT, EVEN IF UNIQUE CONCEPTS HAS BEEN ADVISED OF THE POSSIBILITY OF SUCH DAMAGES.

9. The Customer is not entitled to assign this Limited Warranty to any party. To the maximum extent permitted under applicable law, and at its sole discretion, Unique Concepts is entitled to assign its obligations hereunder to any third party.

10. This Limited Warranty is governed by the laws of the Province of Manitoba and will benefit Unique Concepts and its successors and assigns.

**ACKNOWLEDGEMENT**

THE CUSTOMER ACKNOWLEDGES THAT HE/SHE HAS READ THIS LIMITED WARRANTY, UNDERSTANDS IT, AND AGREES TO BE BOUND BY ITS TERMS AND CONDITIONS. THE CUSTOMER FURTHER AGREES THAT THIS LIMITED WARRANTY CONTAINS THE COMPLETE AND EXCLUSIVE STATEMENT OF AGREEMENT BETWEEN THE PARTIES, AND SUPERSEDES ALL PROPOSALS OR PRIOR AGREEMENTS ORAL AND WRITTEN, AND ANY OTHER COMMUNICATIONS BETWEEN THE PARTIES, RELATING TO THE SUBJECT MATTER OF THIS LIMITED WARRANTY.

\_\_\_\_\_  
Date

\_\_\_\_\_  
Customer

**WARRANTY VOID IF NOT REGISTERED**

SELBY ENGINEERING AND LIFTING SAFETY LTD. TEL: +44 (0) 1977 684 600

LIFTINGSAFETY.CO.UK

## UNIQUE CONCEPTS

### CONFINED SPACE ENTRY/RETRIEVAL UCL SAFETY SYSTEMS POLE HOIST

#### WARRANTY REGISTRATION FORM & INSPECTION REPORT

##### WARRANTY REGISTRATION (please print)

This form must be filled out by the dealer and signed by both the dealer and the customer at the time of delivery.

|                                  |   |
|----------------------------------|---|
| Customer's Name _____            | Dealer Name _____   |
| Address _____                    | Address _____   |
| City, State/Province, Code _____ | City, State/Province, Code _____  |
| Phone Number ( ____ ) _____      | Phone Number ( ____ ) _____   |
| Contact Name _____               | Manufactured by: Unique Concepts Ltd.<br>1500 King Edward Street<br>Winnipeg, Manitoba, Canada<br>R3H 0R5<br>Phone Number (204) 694-7432<br>Fax Number (204) 694-7612<br>Toll Free 1-800-455-9673 |
| Model _____                      |   |
| Serial Number _____              |   |
| Delivery Date _____              |   |

#### DEALER INSPECTION REPORT

#### SAFETY

- |  |  |
|--|--|
| <input type="checkbox"/> All Appropriate Fasteners Torqued<br><input type="checkbox"/> Check that all fasteners and mechanical components are present<br><br><input type="checkbox"/> No Mechanical Damage<br><input type="checkbox"/> Check for finish damage | <input type="checkbox"/> All Labels Installed Correctly and Legible<br><input type="checkbox"/> Review Operating and Safety Instructions |
|--|--|

I have thoroughly instructed the buyer on the above described equipment which review included the Operator's Manual content, equipment care, adjustments, safe operation and applicable warranty policy.

Date \_\_\_\_\_ Dealer's Rep. Signature \_\_\_\_\_

The above equipment and Operator's Manual have been received by me and I have been thoroughly instructed as to care, adjustments, safe operation and applicable warranty policy.

Date \_\_\_\_\_ Owner's Signature \_\_\_\_\_

|                 |        |          |
|-----------------|--------|----------|
| WHITE           | YELLOW | PINK     |
| UNIQUE CONCEPTS | DEALER | CUSTOMER |

SELBY ENGINEERING AND LIFTING SAFETY LTD. TEL: +44 (0) 1977 684 600

LIFTINGSAFETY.CO.UK



### SERIAL NUMBER LOCATION

Always give your dealer or distributor the serial number of your **UCL Pole Hoist** when ordering parts or requesting service or other information.

The serial number plate is located where indicated. Please mark the number in the space provided for easy reference.

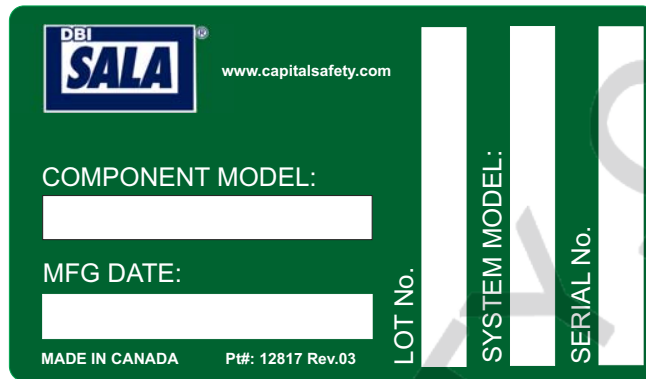

### SERIAL NUMBER LABEL

Model \_\_\_\_\_

Serial Number \_\_\_\_\_



SELBY ENGINEERING AND LIFTING SAFETY LTD. TEL: +44 (0) 1977 684 600

LIFTINGSAFETY.CO.UK

# 1. Introduction:

Congratulations on your choice of a Unique Concepts Man Rated Confined Space Entry/Retrieval Pole Hoist system to compliment your entry/retrieval operation. This equipment has been designed and manufactured to comply with the requirements of **OSHA**, **CE** and **ANSI Z 359.1-1992, A 10.14-1991** to meet the needs of a discriminating operator for the efficient entry/ or retrieval of people from a confined space.

Safe, efficient and trouble free operation and maintenance for your component or system requires that **you** or anyone else who will be operating, maintaining or inspecting the equipment, read, understand and follow all the safety, installation, operation, maintenance & inspection instructions contained in this manual and/or supplied with the system.

This manual covers the **Pole Hoist System** manufactured by Unique Concepts Ltd. Use the table of contents or index as a guide when searching for specific information.

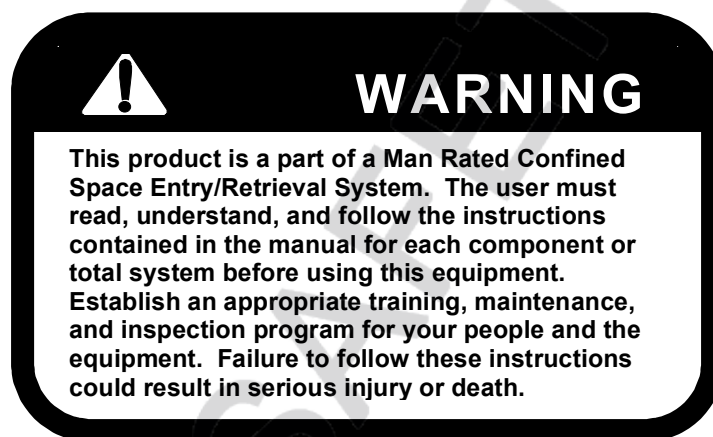

Keep this manual handy for frequent reference and to pass on to new operators. Establish a regular training program for experienced and new operators per these instructions. Establish a regular maintenance and inspection program to keep equipment in top condition.

Modular components are labeled with the capacities & ratings to which they were designed, tested and manufactured. The rating of any system is considered to be the rating of the lowest rated component contained in the system.

Do not use the equipment if rating stickers are damaged or illegible. New stickers are available from the manufacturer. When ordering replacement stickers be sure to include:

1. Part number from bottom right hand side of sticker. (*when available*).
2. Serial number of unit.
3. The part (item) number of the component.
4. Any other numbers stamped on the components.

## 2. Safety:

### SAFETY ALERT SYMBOL

This Safety Alert symbol means **ATTENTION! BECOME ALERT! YOUR SAFETY IS INVOLVED!**

The Safety Alert symbol identifies important safety messages on your equipment and in the manual. When you see this symbol, be alert to the possibility of personal injury or death. Follow the instructions in the safety message.

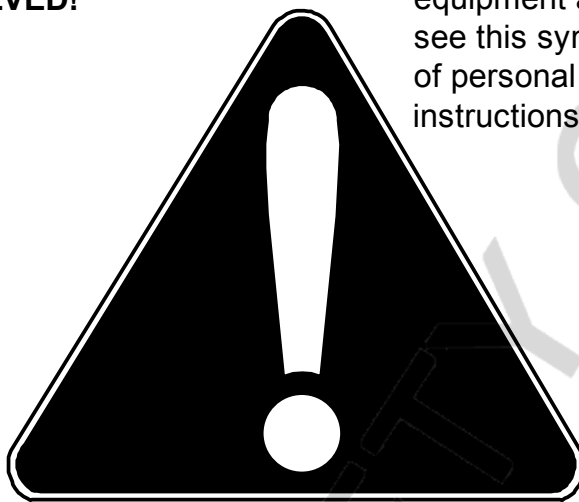

WHY IS SAFETY IMPORTANT TO YOU

#### 3 BIG REASONS

- Accidents Disable and Kill
- Accidents Cost You Money
- Accidents Can Be Avoided

#### SIGNAL WORDS:

Note the use of the signal words **DANGER, WARNING & CAUTION** with the safety message. The appropriate signal word for each message has been selected using the following guidelines.

##### **DANGER:**

Indicates an imminently hazardous situation that, if not avoided, will result in death or serious injury. This signal word is to be limited to the most extreme situations or for hidden and unseen hazards

##### **WARNING:**

Indicates a potentially hazardous situation that if not avoided, could result in serious injury or death, and includes obvious and hidden hazards. It may also be used to alert against unsafe practices.

##### **CAUTION:**

Indicates a potentially hazardous situation that if not avoided, may result in minor or moderate injury. It may also be used to alert against unsafe practices.

## 2. SAFETY: (c'ont)

**YOU** are responsible for the safe operation, maintenance and inspection of your Unique Concepts Man Rated Confined Space Entry/Retrieval Pole Hoist System. **YOU** must ensure that you or anyone else who is going to operate, maintain, inspect or work around the equipment be familiar with the operating & maintenance procedures and the related **SAFETY** information contained in this manual. This manual will take you step-by-step through your working day and alerts you to all good safety and operating practices while using the equipment.

Remember, **YOU** are the key to safety. good safety practices not only protect you but also protect the people around you. Make these practices a working part of your safety program. Be certain that **EVERYONE** operating this equipment is familiar with the procedures recommended and follows the safety precautions. Remember, **most accidents can be prevented**. Do not risk injury or death by ignoring good safety practices.

- Owners **MUST** give operating instructions to operators or employees before allowing them to use the equipment, and at least annually thereafter.
- The most important safety device on this equipment is a **SAFE OPERATOR**. It is the operator's responsibility to read and understand **ALL** safety and operating instructions in the manual and to follow them. **All accidents can be avoided**.
- A person who has not read, been trained in using and does not understand all operating and safety instructions is **not qualified** to operate this equipment. An untrained operator exposes himself and others to possible serious injury or death.
- Do not modify the equipment in any way. Unauthorized modification may impair the function and/or safety and could affect the life of the equipment.
- **THINK SAFELY! WORK SAFELY!**

### 2.1 GENERAL SAFETY:



1. Read, understand and follow the User Manual and all safety signs before using, maintaining or inspecting the equipment.

2. Refer to and follow applicable **ANSI, OSHA, CE** or other standards and local regulations. Comply with all requirements of your local regulations for your applications.

c'ont

## 2.1 GENERAL SAFETY: (c'ont)

3. Establish an Equipment-use training program for experienced employees. Only trained competent persons shall use the equipment. An untrained operator is not qualified to operate the system.

4. Have a first-aid kit available for use should the need the arise and know how to use it.



5. Provide a fire extinguisher for use in case of an accident. Store in a highly visible place.



6. Install and properly secure all guards and shields before operating.

7. Wear appropriate protective gear. This list includes but is not limited to:

- hard hat
- safety glasses
- heavy gloves
- face protection
- protective shoes with slip resistant soles
- protective clothing



8. Review and follow the pre-operation inspection before using a component in the system or the system itself.

9. Establish a regular maintainance & inspection program with your equipment and maintain detailed records.

10. Review safety related items and operating instructions with all personal on a regular basis.

11. Be aware of your enviromental surroundings, be sure not to use the equipment during an electrical storm. (*this equipment is conductive*)

12. Our winch does not exceed 70 dba. noise level.



## 2.2 OPERATING SAFETY:

1. Read, understand and follow the operators manual and signs on the equipment before using, maintaining or inspecting the equipment.

c'ont

## 2.2 OPERATING SAFETY: (c'ont)

2. Train all operators before allowing them to use the equipment. An untrained operator exposes themselves, bystanders and workers to possible serious injury or death.
3. Visually inspect the equipment and all auxillary components and equipment before using. correct any problems before using the equipment.
4. Securely anchor the winch before using, where applicable.
5. Use only certified anchor and connectors components in your system.
6. Use only an approved full body harness for your workers.
7. Always work in teams. One person works in the confined space and the other pays out the line and reels it in.
8. Do not use the winch when the brake wear indicator displays in the red or the counter exceeds 30,000 cycles or 5 years. Return winch to the manufacturer for service. ( *refer to Digital Winch Operators manual for detailed information on winch operation.* )
9. Do not exceed 450 lbs. (205 kg) on the line during operation.
10. Establish a regular training program for new & experienced workers.
11. Establish a detailed inspection program for your equipment and document the findings. Return the equipment to the manufacturer for rework if any problems are found.
12. Plan your work program before starting. Have the required people, equipment and procedures available to do the job.
13. Do not use the equipment around physical or enviromental hazards. This list includes, but is not limited to:
  - a] corrosion that may affect the structural integrity of the lifeline or other components.
  - b] chemicals which may degrade components and may not be visible.
  - c] Toxic gases: rescuers and/or workers can be killed in toxic enviroments.
  - d] heat or elevated temperatures.
  - e] moving machinery: workers or auxillary equipment can be contacted by or pulled into moving components.
  - f] sharp edges: workers or equipment can be injured or damaged by sharp edges or components.

## 2.2 OPERATING SAFETY: (c'ont)

13. Do not use the equipment around physical or environmental hazards. This list includes, but is not limited to: (c'ont)

- g] electrical hazards: stay away from power lines or components carrying electrical power
- h] overload: do not exceed 450 lbs. (205 kg.) during operation.
- i] follow all confined space regulations in standards.
- j] noise: wear appropriate noise protection where necessary
- k] environmental hazards: do not operate equipment during an electrical storm

## 2.3 MAINTENANCE / INSPECTION SAFETY:

1. Read, understand and follow the User manual and signs on the equipment before using, maintaining or inspecting the equipment.
2. **ANSI, OSHA & CE** require a regular inspection program for all Confined Space Entry/Retrieval equipment and to maintain documented results of these inspections. Follow the inspection procedure contained in this manual and use the inspection form to document the results.
3. Keep instructional and safety signs clean and legible at all times. clean or replace as required.
4. Lubricate winch as per instruction in the digital winch operators manual.
5. Remove the equipment from service if a problem is found during the inspection. Return to a authorized repair depot or factory for service.

## 3 OPERATING, NEW OPERATOR or OWNERS:

The Pole Hoist System is designed to attach to a person( *entrant*) and allow them to enter a confined space and assist in exiting if required. Every new operator must read, understand and follow the instructions in all applicable manuals. No one should be allowed to use the equipment without training. The training should be reviewed with experienced operators on a regular basis. At regular intervals perform a detailed inspection of the equipment and document the results. Remove from service if any deficiencies are found. Alterations or misuse of this equipment or the failure to follow the instruction may result in serious injury or death.

c'ont



### **3 OPERATING, NEW OPERATOR or OWNERS:**

**It is the responsibility of the owner's organization or operator to read this manual and to train all other operators before they start working with the equipment. Follow all safety instructions exactly. Safety is everyone's business. by following recommended procedures a safe working environment is provided for the operator, bystanders and the area around the work site. Untrained operators are not qualified to operate this equipment.**

Many of the features incorporated into this equipment are a result of suggestion made by customers like you. read this manual carefully to learn how to operate the equipment safely and how to set it to perform as intended. By following the operating instruction in conjunction with a good maintenance program, your equipment will provide many years of trouble-free service.



#### **OPERATING SAFETY**

1. Read, understand and follow the operators manual and signs on the equipment before using, maintaining or inspecting the equipment.
2. Train all operators before allowing them to use the equipment. An untrained operator exposes themselves, bystanders and workers to possible serious injury or death.
3. Visually inspect the equipment and all auxillary components and equipment before using. correct any problems before using the equipment.
4. Securely anchor the winch before using, where applicable.
5. Use only certified anchor and connectors components in your system.
6. All anchor points, or mounting/setup locations for permanent or portable systems must be approved to local standards by a qualified engineer.
7. Use only an approved full body harness for your workers.
8. Always work in teams. One person works in the confined space and the other pays out the line and reels it in.
9. Do not use the winch when the brake wear indicator displays in the red or the counter exceeds 30,000 cycles or 5 years. Return winch to the manufacturer for service. ( *refer to Digital Winch Operators manual for detailed information on winch operation.* )

c'ont



## OPERATING SAFETY

c'ont

10. Do not exceed 450 lbs. (205 kg) on the line during operation.
11. Use only retractable lifelines or shock absorbers with a maximum arresting force ( **MAF**) equal to or lower than the lowest rated component of your system.
12. Establish a regular training program for new & experienced workers.
13. Establish a detailed inspection program for your equipment and document the findings. Return the equipment to the manufacturer for rework if any problems are found.
14. Plan your work program before starting. Have the required people, equipment and procedures available to do the job.
15. Do not use the equipment around physical or environmental hazards. This list includes, but is not limited to:
  - a] corrosion that may affect the structural integrity of the lifeline or other components.
  - b] chemicals which may degrade components and may not be visible.
  - c] Toxic gases: rescuers and/or workers can be killed in toxic environments.
  - d] heat or elevated temperatures.
  - e] moving machinery: workers or auxiliary equipment can be contacted by or pulled into moving components.
  - f] sharp edges: workers or equipment can be injured or damaged by sharp edges or components.
  - g] electrical hazards: stay away from power lines or components carrying electrical power
  - h] overload: do not exceed 450 lbs. (205 kg.) during operation.
  - i] follow all confined space regulations in standards.
  - j] noise: wear appropriate noise protection where necessary
  - k] environmental hazards: do not operate equipment during an electrical storm

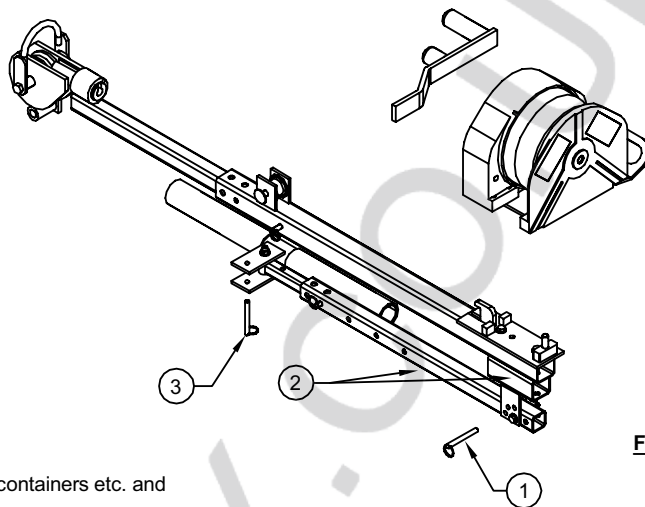

**FIG. 1**

**A) Setting up the Pole Hoist**

1. Remove all parts from storage / transport bags containers etc. and layout on ground as shown in Fig. 1.
2. Remove Pin(1) from T-bar leg assembly(2), rotate leg as shown in Fig. 2 and replace pin as shown in Fig. 2. Remove Pin(3) from T-bar leg assembly rotate foot assembly as shown in Fig. 2 and replace pin.
3. Remove Pin(4) to adjust T-bar leg assembly to a comfortable height for winch operation.

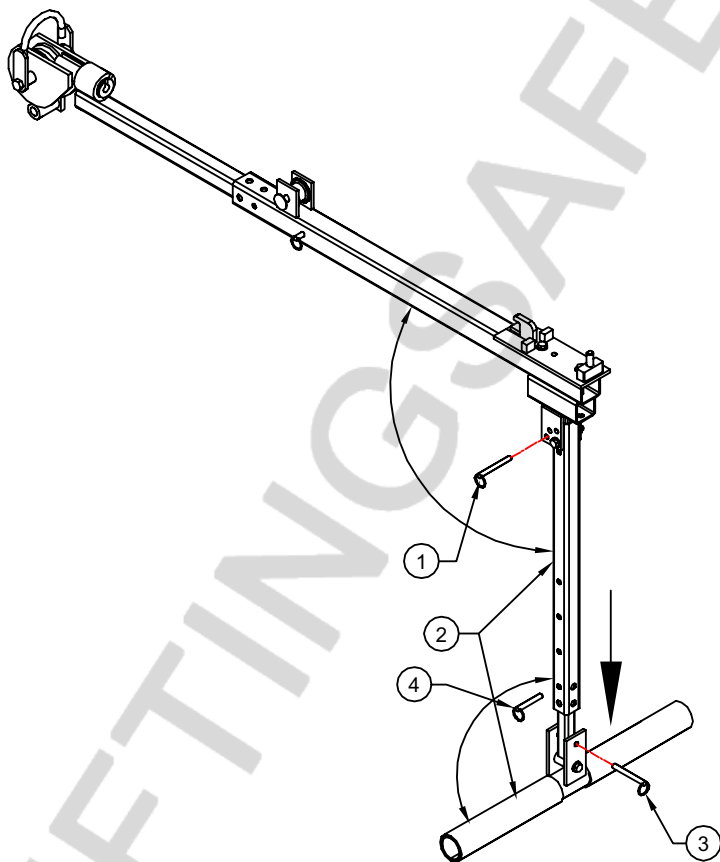

**FIG. 1**

SELBY ENGINEERING AND LIFTING SAFETY LTD. TEL: +44 (0) 1977 684 600

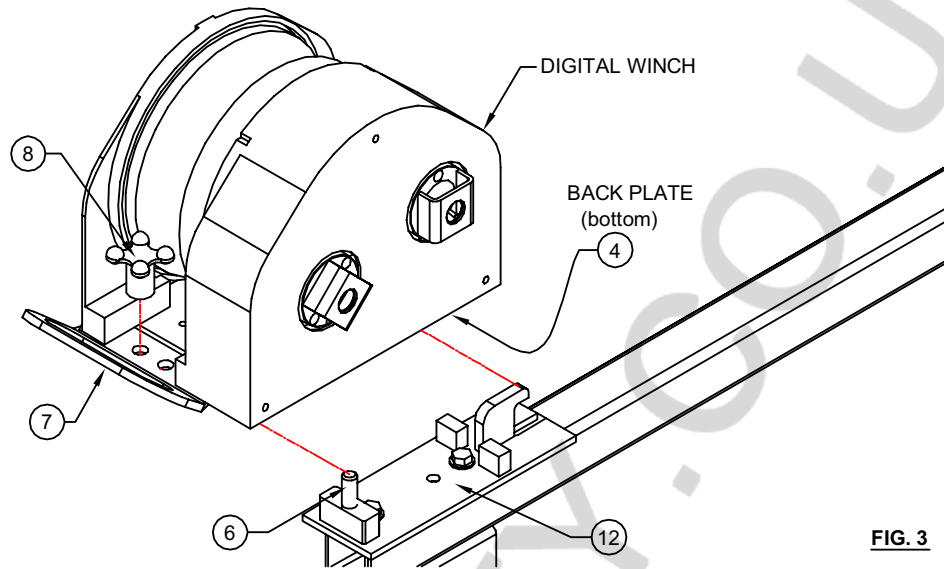

FIG. 3

**B) Winch & Cable routing installation**

1. Install winch with upper slot in back plate(4) over hook on flat quick mount plate(5).
2. Swing winch in and down so that the mounting stud(6) engages the hole in the winch carrying handle(7).
3. Thread clamp knob(8) onto stud(6) and tighten securely by hand.
4. Pay out 5' to 10' of cable from winch, maintaining at least 10 lb. (5 kg) of tension on cable at all times.  
*(Please refer to winch manual)*
5. Remove cable roller pin(9) & guide pulley(10) from pole hoist mast assembly(11). Place cable under guide pulley and replace guide pulley & cable roller pin.
6. Rotate pole hoist head assembly(12) so that slots through head align. Place cable through slot in head assembly and over pulley and around cable retainer spring(13). See Fig. 5 for cable path through head assembly.

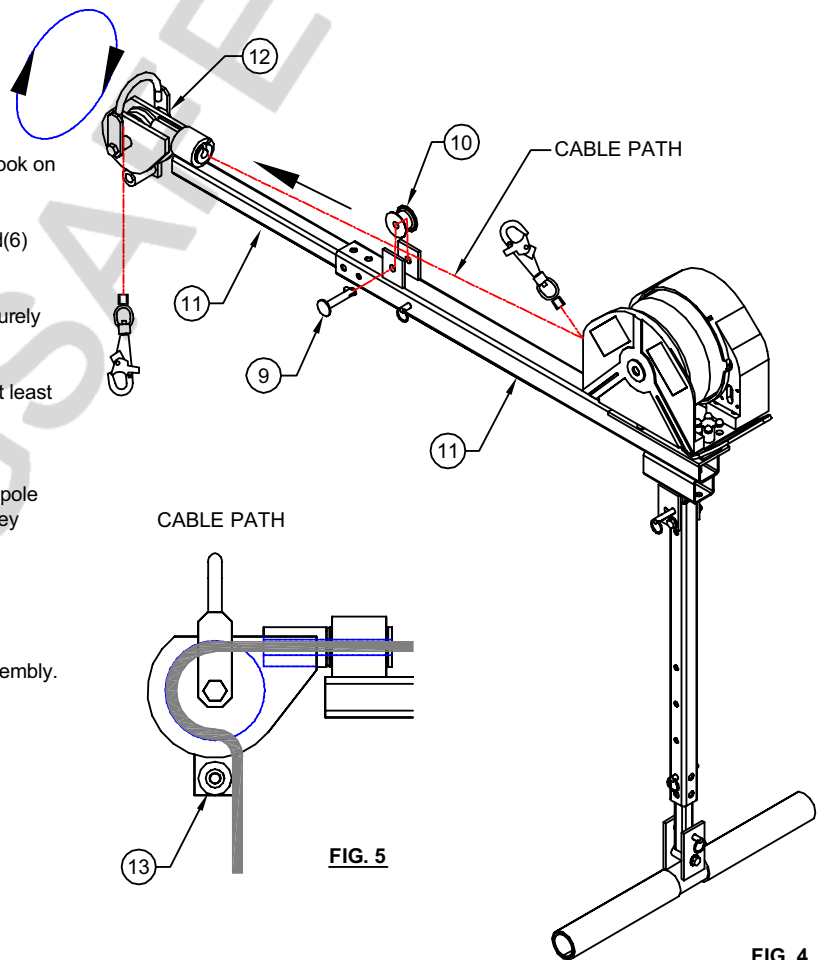

FIG. 4

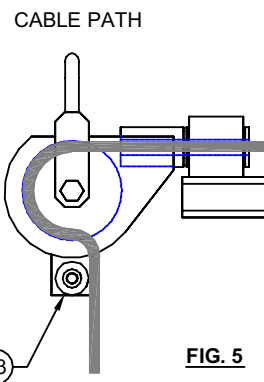
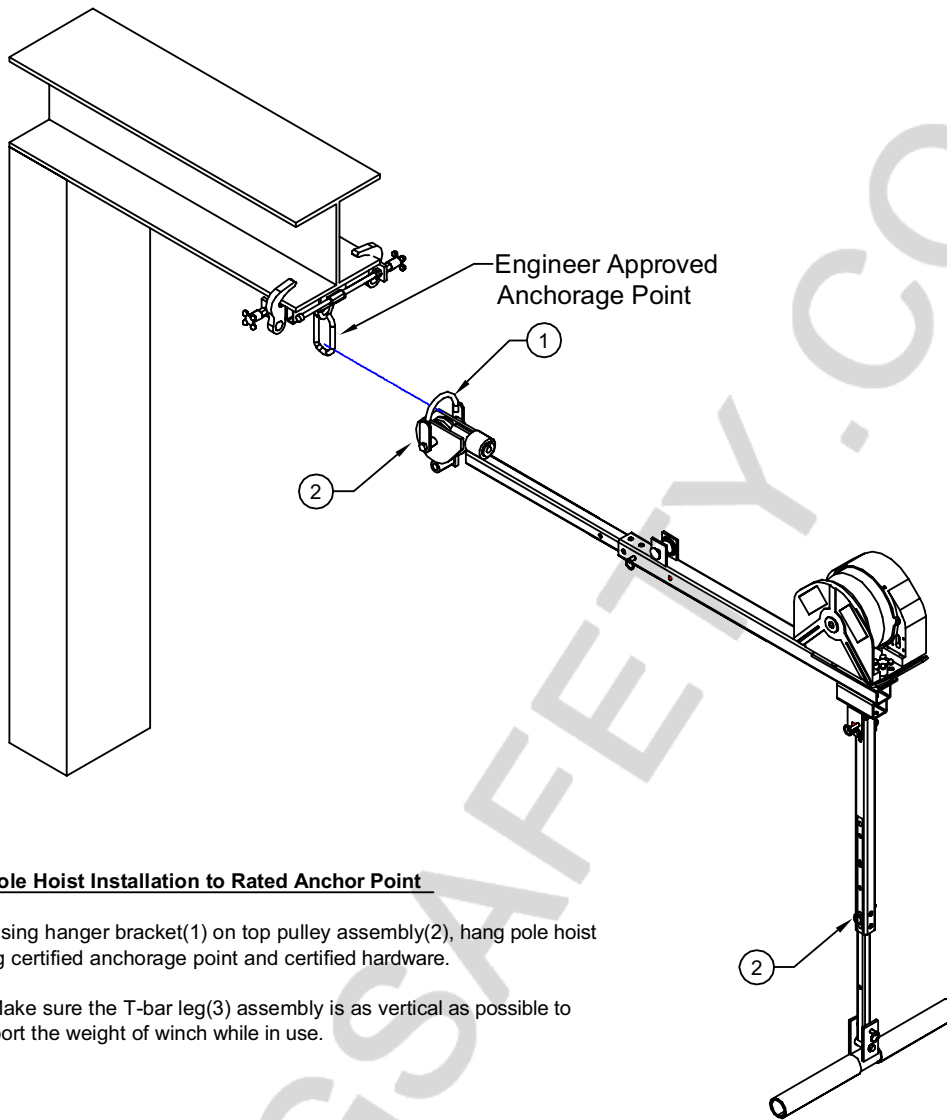

FIG. 5

SELBY ENGINEERING AND LIFTING SAFETY LTD. TEL: +44 (0) 1977 684 600



**C) Pole Hoist Installation to Rated Anchor Point**

1. Using hanger bracket(1) on top pulley assembly(2), hang pole hoist using certified anchorage point and certified hardware.
2. Make sure the T-bar leg(3) assembly is as vertical as possible to support the weight of winch while in use.

**FIG. 6**

**D) INSTALLATION OF WINCHES, SELF-RETRACTING LIFELINES ( SRL's), WORK POSITIONING AND FALL-ARREST DEVICES NOT MANUFACTURED BY UNIQUE CONCEPTS LTD.**

Your Pole-Hoist system can be used as a support structure for various types of safety devices.

Any accessories being used for the hoist **MUST BE** installed, inspected, maintained and operated according to the manufactures instructions. All installations **MUST BE** approved to local standards by a qualified engineer.

**E) INSPECTION OF EQUIPMENT PRIOR TO USE.**

- Check all structural parts for damage: dents, cracked welds bend or crushed tubes. Minor cosmetic damage will not affect the structural integrity of the hoist, but any seriously damaged parts **MUST BE** repaired or replaced before using the hoist.

- Check all hardware ( pins, tri-screws, adjuster screws, nuts, bolts, pulleys, rollers and winch brackets) for damaged threads, bend, damaged or missing fasteners, loose fasteners. Check all pulleys and rollers for chips, grooves and excessive wear. Ensure that all pulleys and rollers turn freely.

- Inspect all equipment for missing, damaged or otherwise illegible warning stickers. Any damaged, missing or otherwise illegible stickers **MUST BE** replaced before using hoist.

- If you are using UCL Safety Systems Winches with your hoist, inspect the winch and cable as outlined in the "maintenance and inspection" section of the Digital Series Winch operators manual.

- Any additional winches, self-retracting lifelines (SRL's), work positioning or fall-arrest equipment being used with your UCL Safety Systems Hoist **MUST BE** installed, inspected, maintained and operated according to the manufactures instruction.

- Report any problems with the equipment to your supervisor and **DO NOT USE** the equipment until it has been repaired or replaced.

**F) INSPECTION / MAINTENANCE SCHEDULE**

**DAILY ( BEFORE EACH USE ) :** (SEE ABOVE) INSPECTION OF EQUIPMENT PRIOR TO USE

**WEEKLY:** Perform a complete visual inspection of equipment as outlined in " Inspection of Equipment Prior to Use". Clean equipment as required, to thoroughly inspect all welds, labels, pins, fasteners, pulleys, rollers, brackets and parts. Record all findings on a copy of the "hoist inspection log". If any problems are found with the equipment **DO NOT USE** until it has been repaired.

**ANNUALLY:** Clean unit thoroughly, using a damp cloth and a mild soap solution. Perform a complete visual inspection as described in section(F) " Inspection of Equipment Prior to Use" Record all findings on a copy of the "hoist inspection log". If any problems are found with the equipment **DO NOT USE** until it has been repaired.



| MODEL # | SERIAL # | MFG. DATE |
|---------|----------|-----------|
|---------|----------|-----------|

**HOIST INSPECTION LOG:** (SAMPLE FORM - Copy to start inspection log book)

**TYPE OF INSPECTION:**  DAILY  WEEKLY  ANNUALLY

| Date of Inspection (d / m / y)                                    |               |  |  |  |  |  |  |  |  |
|---|---------------|--|--|--|--|--|--|--|--|
| Inspected By:   |               |  |  |  |  |  |  |  |  |
| T<br>B<br>A<br>R<br>L<br>E<br>G                                   | LABELS        |  |  |  |  |  |  |  |  |
|   | BASE TUBE     |  |  |  |  |  |  |  |  |
|   | DAMAGE        |  |  |  |  |  |  |  |  |
|   | CORROSION     |  |  |  |  |  |  |  |  |
|   | FASTENERS     |  |  |  |  |  |  |  |  |
|   | PINS          |  |  |  |  |  |  |  |  |
|   | WELDS         |  |  |  |  |  |  |  |  |
|   | OTHER         |  |  |  |  |  |  |  |  |
| H<br>O<br>I<br>S<br>T<br><br>A<br>S<br>S<br>E<br>M<br>B<br>L<br>Y | LABELS        |  |  |  |  |  |  |  |  |
|   | DAMAGE        |  |  |  |  |  |  |  |  |
|   | CORROSION     |  |  |  |  |  |  |  |  |
|   | FASTENERS     |  |  |  |  |  |  |  |  |
|   | PULLEYS       |  |  |  |  |  |  |  |  |
|   | ROLLER        |  |  |  |  |  |  |  |  |
|   | U-BRACKET     |  |  |  |  |  |  |  |  |
|   | WINCH BRACKET |  |  |  |  |  |  |  |  |
|   | SRL's BRACKET |  |  |  |  |  |  |  |  |
|   | WELDS         |  |  |  |  |  |  |  |  |
| OTHER   |               |  |  |  |  |  |  |  |  |

\* FAILURE TO COMPLY AND FOLLOW REGULAR INSPECTION PROCEDURES STATED IN THIS MANUAL WILL RESULT IN VOIDING OF THE MANUFACTURES WARRANTY AND / OR POSSIBLE SERIOUS INJURY OR DEATH TO THE OPERATOR / ENTRANT.



**Capital Safety** USA: 800.328.6146 • Canada: 800.387.7484 • Asia: + 65 6558 7758 •  
 Australia/New Zealand: 800 245 002 • Europe, Middle East, Africa: +33 (0) 497 10 00 10 •  
 Northern Europe: +44 (0) 1928 571324  
[www.capitalsafety.com](http://www.capitalsafety.com) • [info@capitalsafety.com](mailto:info@capitalsafety.com)

**ISO 9001**  
 REGISTERED

SELBY ENGINEERING AND LIFTING SAFETY LTD. TEL: +44 (0) 1977 684 600





The winch assembly supplied with your UCL Safety Systems Pole Hoist may be used with a variety of additional options for entry of more specialized confined spaces.

This appendix contains a general product selection procedure and pictorial guide to the many options available

For more detailed information or for assistance with product selection, please feel free to contact your local dealer or UCL Safety Systems at the address on the back of this manual.





## LABELS

### Warning Labels

The UCL Pole Hoist uses a label rating system that is attached to all components on the system.

The operator and/or entrant must establish the local standards by a qualified engineer and only then, a decision can be made by the rating labels as to which is the lowest rated component and if it meets or exceeds local standards.

Proper maintenance of the labels must be established by the operator/entrant to keep system use safe. If labels are damaged the operator/entrant must enforce a lock-out/tag-out procedure. New labels are available from the local dealer or UCL manufacturer.



## WARNING

This component is rated for a working load of 450 lb. (205 kg.). Retractable devices or shock absorbers must have a **MAXIMUM ARRESTING FORCE (M.A.F.) RATING OF 900 LB. (4KN) OR LESS.** System rating is that of the lowest rated system component.

Pt #13219

LIFTINGSAFETY.CO.UK



**Capital Safety** USA: 800.328.6146 • Canada: 800.387.7484 •  
Asia: + 65 6558 7758 • Australia/New Zealand: 800 245 002 •  
Europe, Middle East, Africa: +33 (0) 497 10 00 10 •  
Northern Europe: +44 (0) 1928 571324  
**www.capitalsafety.com • info@capitalsafety.com**