

Vi-Go

Vertical Arrest System

SELBY ENGINEERING & LIFTING SAFETY LTD.
Lifting Equipment and Height Safety Specialists
www.liftingsafety.co.uk sales@liftingsafety.co.uk
Tel: +44 (0) 1977 684 600 Fax: +44 (0) 1977 685 300

The unique & versatile system

Söll Vi-Go is a fall protection system used in OEM or retrofitted onto existing climbing devices such as ladders or rungs used in wind turbine, power supply, telecommunication or other industries.

The system, which can support up to 8 workers, consists of:

- approved cable (three diameters and two materials for choice)
- ergonomic interfaces and
- a revolutionary guided-type fall arrester adaptable with all approved diameters of cable

Components are made from high quality materials with corrosion resistant finishes. **Söll Vi-Go** system is especially versatile and very simple to install thanks to its very few components. **Söll Vi-Go** is available in different models and materials.

Ergonomic Interfaces

Söll Vi-Go interfaces give access to different applications from the most standard to the most specific. The system offers installation compatibility in a wide variety of environments (vibration, wind, rain, heat) and has been designed to increase user safety.

Unrivall fall arrester

Due to its technological design and internal mechanisms, the fall arrester is extremely safe as it eliminates incorrect usage and due to its absorbing element reduces the fall impact on the user. In the event of a fall, the system (cable & interfaces) does not require alteration hence only requires an inspection by a competent person.

Global Product - safe - user friendly!

Söll Vi-Go is approved and certified according to the most important international norms (e.g. EN 353-1, ANSI, AS/NZS 1891.3, & GB 6095-85/6096-85).



Söll Vi-Go – the new vertical steel cable system with integrated fall protection



Safety for all users

Each fall arrester is equipped with a shock absorbing element made of stainless steel which is unique to **Söll**.

This highly effective, durable absorber reduces the impact force to a minimum on a worker's body in the event of a fall. The value falls considerably below 6 KN which is stipulated in the EN 353-1 standard.

Since each shuttle is equipped with a cushioning element as opposed to being on the cable, the loads on the cable fixings are effectively reduced when there are several users. After a fall the cable does not necessarily need to be replaced.

Easy handling of the shuttle

The very ergonomic design of the new Söll Vi-Go shuttles distinguishes them from their competitors.

The shuttle can be unlocked and fastened to or unfastened from the rope with a single hand. Incorrect attachment is not possible. The dual locking mechanism renders the fall arrester particularly safe.

The spring-activated securing mechanisms always move the device back to its initial position.

Ease of use

The user wears a full body harness (EN 361 compliant) and fastens the karabiner hook of the **Söll Vi-Go** shuttle to the fall protection/fall arrest attachment ring of a harness. The unlock button is pressed with the thumb; the slider can then be opened using fingers. The shuttle can be placed on the approved cable by lifting the latch slightly.

Users can start climbing or descending once the shuttle has been fixed to the cable. The short distance between the harness and the shuttle is ergonomically positive and very safe.

The advantages at a glance

- smooth traveling shuttle with single-hand-operation, adoptable for all approved diameters of cable
- high quality and corrosion resistant finishes
- effective shock absorber in the shuttle protects every user and the cable against damages
- safety for up to a maximum of 8 users at any one time
- system comprises of a limited number of components, which are adoptable and easy to install
- globally approved system



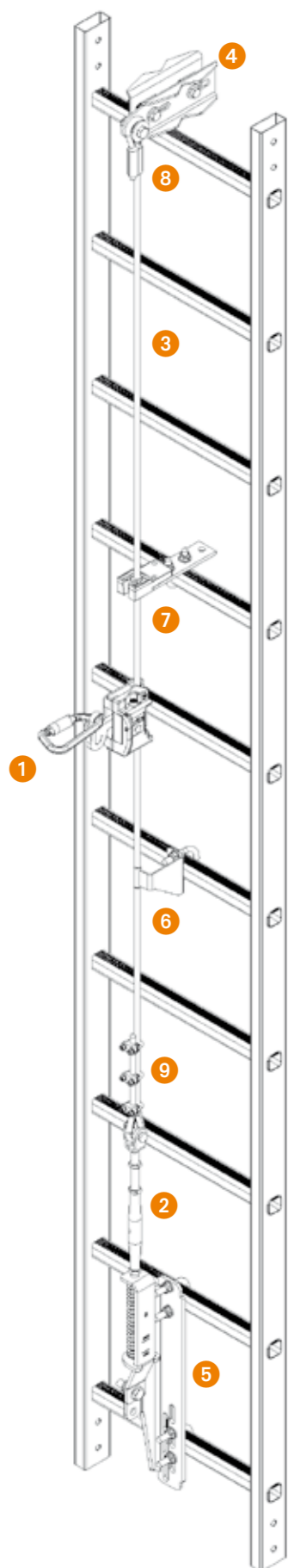

1 Guided-type fall arrester

- The fall arrester is quick and easy to use as a result of its absolute single-hand operation.
- The dual locking mechanism is especially safe and prevents accidental unlocking of the fall arrester from the cable.
- Not using a textile shock absorber considerably reduces ownership costs for damaged or old shock absorbers.
- After a fall the cable does not necessarily need to be replaced. Inspection by a competent person is required!
- An integrated mechanism prevents incorrect fastening of the shuttle to the cable (headfirst).
- Corrosion-resistant, repairable stainless steel shuttle requires minimum maintenance. It has been designed such that repairing becomes easy and inexpensive.

Patent pending



2 Cable tensioner

- Three functions are integrated including:
 - tensioner
 - tension indicator
 - expansion compensator
- It is easy to install and can compensate the movements of the structure.
- Available in stainless and galvanized steel. The shuttle is available with a swivel snap karabiner hook for the North American market and with a webbing loop for the British market.

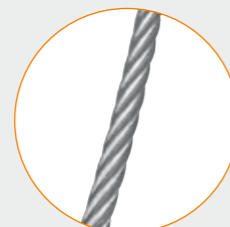

3 Söll-Steel cable - approved

- Cable 8 mm, 7 x 19, stainless steel
- Cable 8 mm, 7 x 19, galvanized
- Cable 10 mm, 7 x 19, stainless steel
- Cable 10 mm, 7 x 19, galvanized
- For the North American market: Cable 3/8", 7 x 19, stainless steel
- Cable 3/8", 7 x 19, galvanized



4 Universal clamp

- Serves as cable fixing.
- A unique feature of the universal clamp is that it can be fastened to pipe structures of various diameters as well as angular or flat steel profiles depending on the assembly.
- Available in stainless and galvanized steel.

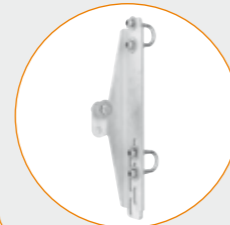

5 Rung clamp

- An alternative to the universal clamp; the cable can be directly fastened to the rungs of a ladder.
- Various elongated holes at varying distances from each other make it possible for the rung clamp to be mounted on the most varied of ladders.
- Available in stainless and galvanized steel.



Intermediate brackets

Intermediate brackets hold the cable in position and prevent it from moving excessively in windy environmental conditions.



6 Automatic brackets

Söll Vi-Go shuttles can pass through automatic brackets **without manual help**. This offers greater comfort and convenience hence this system should be your number 1 choice! The bracket must be installed by passing the cable through it. Its biggest advantages are user comfort, quicker climbing and descending and highest levels of safety.



7 Manual brackets

In case of manual brackets, the cable must be released from the clamping position before a shuttle passes through it. The cable must be clamped back in the manual brackets before getting off from the system. Manual brackets are cost-effective, light and can also be retrofitted.



Cable end parts

There are three alternatives to choose from:

8 Cable thimble

- Special advantages are the saving of component costs and time during assembly.
- The cable thimble is available for 8 & 10 mm cables.



9 Cable sling

- A cable sling can be used for both top & bottom ends of the system. The cable length is variable. Available for 8 & 10 mm steel cables.
- In addition to the money it saves, this variant also proves to be extremely flexible during installation.



Pluggable rope ends

- This solution, available for all cable types, is especially sophisticated and quick and yet sufficiently flexible.
- It requires minimal time for installation.

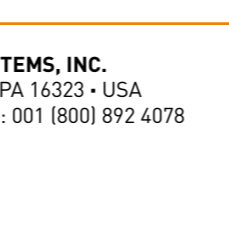

Platform support

- The platform support allows the unique opportunity to step safely onto the platform from over the top end of the ladder.
- The fall protection cable is extended over the ladder for this purpose.

SPERIAN FALL PROTECTION
 Deutschland GmbH & Co. KG
 Seligenweg 10 · 95028 Hof · Germany
 Tel.: +49/92 81/83 02-0 · Fax: +49/92 81/36 32
 soell@sperianprotection.com · www.vi-go.eu

SPERIAN FALL ARREST SYSTEMS, INC.
 1345 15th Street · Franklin · PA 16323 · USA
 Tel.: 001 (800) 325 6746 · Fax: 001 (800) 892 4078
 soll@sperianprotection.com

SPERIAN FALL PROTECTION Australia PTY LTD
 3 Walker St · Braeside Victoria 3195 · Australia
 Australia Phone: 00 61 1300 139 166
 New Zealand Phone: 00 64 0800 322 200

